



HP xw4600 Workstation

Service and Technical Reference Guide

Copyright Information

© 2008-2009 Copyright Hewlett-Packard Development Company, L.P.

Warranty

Hewlett-Packard Company shall not be liable for technical or editorial errors or omissions contained herein or for incidental or consequential damages in connection with the furnishing, performance, or use of this material. The information in this document is provided "as is" without warranty of any kind, including, but not limited to, the implied warranties of merchantability and fitness for a particular purpose, and is subject to change without notice. The warranties for HP products are set forth in the express limited warranty statements accompanying such products.

Nothing herein should be construed as constituting an additional warranty.

This document contains proprietary information that is protected by copyright. No part of this document may be photocopied, reproduced, or translated to another language without the prior written consent of Hewlett-Packard Company.

Trademark Credits

Microsoft and Windows are U.S. registered trademarks of Microsoft Corporation.

Intel is a trademark of Intel Corporation in the U.S. and other countries.

ENERGY STAR is a U.S. registered mark of the United States Environmental Protection Agency.

453080-006

Sixth Edition, November 2009

Table of contents

1 Product overview

Product features	2
System board architecture	2
Workstation components	2
Front panel components	4
Rear panel components	5
Serial number and COA label location	6
Maximizing the airflow	6
Workstation specifications	7
Power supply description	7
Power supply specifications	8
Power consumption and heat dissipation	8
System fans	9
Resetting the power supply	9
Environmental specifications	9
ENERGY STAR Qualification	9
Dual- and quad-core processors	10
HP Cool Tools	11

2 Setting up the operating system

Setting up the Microsoft operating system	13
Installing or upgrading device drivers	13
Transferring files and settings to your Windows workstation	13
Setting up Red Hat Enterprise Linux	14
Installing with the HP driver CD	14
Installing and customizing Red Hat-enabled workstations	15
Verifying hardware compatibility	15
Setting up Novell SLED	15
Updating the workstation	15
Updating the workstation after first boot	15
Upgrading the BIOS	15
Determining current BIOS	16
Upgrading BIOS	17
Upgrading device drivers	17

3 Restoring the operating system

Restore methods	18
Ordering backup software	19

Restoring Windows Vista	19
Ordering the RestorePlus! media	19
Restoring the operating system	19
Restoring Windows XP Professional	20
Creating RestorePlus! media	20
Creating HP Backup and Recovery (HPBR) media	21
Restoring the operating system	22
Using RestorePlus!	22
Using HPBR	22
Using the recovery partition	22
Restoring Novell SLED	22
Creating restore media	22

4 System management

Computer Setup (F10) Utility	24
BIOS ROM	26
Using the Computer Setup (F10) Utility	26
Computer Setup (F10) Utility menu	27
Workstation management	33
Initial workstation configuration and deployment	34
Installing a remote system	34
Replicating the setup	34
Copying a setup configuration to a single workstation	35
Copying a setup configuration to multiple workstations	36
Updating and managing software	37
HP Client Manager Software	37
Altiris Client Management Solutions	37
System Software Manager	37
Proactive Change Notification	38
Subscriber's Choice	38
ROM Flash	39
Remote ROM Flash	39
HPQFlash	39
FailSafe Boot Block ROM	40
Asset tracking and security	41
Password security	42
Establishing a setup password using the Computer Setup (F10) Utility	42
Establishing a power-on password using workstation setup	42
Entering a power-on password	43
Entering a Setup Password	43
Changing a power-on or setup password	43
Deleting a power-on or setup password	45
National keyboard delimiter characters	45

Clearing passwords	45
DriveLock	45
Hood Sensor (Smart Cover Sensor) (optional)	48
Setting the Hood Sensor protection level	48
Hood Lock (Smart Cover Lock) (optional)	48
Locking the Hood Lock	48
Unlocking the Hood Lock	49
Using the FailSafe key	49
Cable lock (optional)	49
Security lock (Padlock loop) (optional)	49
Universal chassis clamp lock (optional)	49
Fault notification and recovery	49
Drive Protection System	50
ECC fault prediction	50
Thermal sensors	50
Dual-state power button	50

5 Removal and replacement procedures

Warnings and cautions	51
Service considerations	52
Cautions, warnings, and safety precautions	52
ESD information	52
Generating static	52
Preventing ESD equipment damage	53
Personal grounding methods and equipment	53
Grounding the work area	54
Recommended ESD prevention materials and equipment	54
Tools and software requirements	54
Screws	55
Special handling of components	55
Cables and connectors	56
Hard drives	56
Lithium coin cell battery	56
Customer Self-Repair	56
Predisassembly procedures	57
System board components	57
Removing and replacing components	58
Disassembly order	59
Security lock (Padlock loop) (optional)	59
Removing the security lock	60
Cable lock (optional)	60
Removing the cable lock	60
Universal chassis clamp lock (optional)	60

Removing the chassis clamp lock	61
Side access panel	61
Removing the side access panel	61
Replacing the side access panel	62
Hood Sensor (Smart Cover Sensor) (optional)	63
Removing the Hood Sensor	63
Smart Cover Lock solenoid (optional)	63
Removing the Smart Cover Lock solenoid	63
Front bezel	64
Removing the front bezel	65
Replacing the front bezel	65
Bezel blanks	65
Removing bezel blanks	65
Front panel I/O device assembly	66
Removing the front panel I/O device assembly	66
Installing the front panel I/O device assembly	67
Power button assembly	68
Removing the power button assembly	68
System speaker	69
Removing the system speaker	69
Power supply	70
Removing the power supply	70
System fan assembly	71
Removing the system fan assembly	71
Memory	72
Removing a memory module	72
Installing a memory module	73
Supported DIMM configurations	73
Memory module requirements	73
Required DIMM installation order	74
Installing a memory module	74
PCI card slots	76
PCI card support bracket	76
Removing a PCI card support bracket	77
Installing a PCI card support bracket	77
PCI Express cards	78
Removing a PCI Express card	78
Installing a PCI Express card	79
PCI card	80
Removing a PCI card	80
Installing a PCI card	81
IEEE-1394 card (optional)	82
Removing an IEEE-1394 card	82
Front PCI card guide and fan removal (optional)	83

Removing the front PCI card guide and fan	83
Battery	84
Removing the battery	85
Installing the battery	85
Power connections to drives	86
Optical drive (minitower configuration)	87
Notice for Blu-ray optical drives	87
Blu-ray movie playback	87
Blu-ray movie playback compatibility and update	87
Removing an optical drive (minitower configuration)	88
Installing an optical drive (minitower configuration)	89
Optical drive (desktop configuration)	90
Removing an optical drive (desktop configuration)	90
Installing an optical drive (desktop configuration)	91
Diskette drive (optional)	92
Removing a diskette drive	92
SAS hard drive	93
Removing a SAS hard drive	93
Installing a SAS hard drive	95
SATA hard drive	97
Removing a SATA hard drive	97
Installing a SATA hard drive	98
Installing SATA hard drives in the optical drive bays (optional)	100
Processor heatsink	101
Removing the processor heatsink	101
Installing the processor heatsink	103
System processor	103
Removing a system processor	103
Installing a system processor	104
System board	105
Removing the system board	105
Installing the system board	106
Product recycling	106

6 System diagnostics and troubleshooting

HP troubleshooting resources and tools	107
HP Support Assistant	107
HP Help and Support Center	107
E-support	108
Troubleshooting a problem	108
Instant Support and Active Chat	108
Customer Advisories, Customer and Security Bulletins, and Customer Notices	108
Product Change Notifications	109

Helpful hints	109
At startup	109
During operation	109
Customizing the monitor display	110
Customer Self Help	110
Help and Support Center	110
HP SoftPaq Download Manager	111
Diagnostic LED codes	111
Troubleshooting scenarios and solutions	113
Solving minor problems	113
Solving power supply problems	114
Testing power supply	114
Solving diskette problems	116
Solving hard drive problems	117
Solving display problems	118
Solving audio problems	120
Solving printer problems	121
Solving keyboard and mouse problems	122
Solving front panel component problems	123
Solving hardware installation problems	124
Solving network problems	125
Solving memory problems	126
Solving processor problems	127
Solving DVD problems	127
Solving Internet access problems	128
Troubleshooting checklist	129
LED color definitions	130
Self-troubleshooting with HP Vision Field Diagnostics	130
Overview	131
Downloading and accessing HP Vision Field Diagnostics	132
Accessing HP Vision Field Diagnostics on the workstation	133
Creating and using a bootable USB key	133
Creating and using a bootable DVD	133
Using the HP Memory Test utility	133
User interface	134
Survey tab	134
Test tab	136
Status tab	138
History tab	138
Errors tab	138
Help tab	139
Saving and printing information in HP Vision Field Diagnostics	140
POST error messages	140

7 Configuring RAID devices

Maximum hard drive configurations	146
Configuring SATA RAID devices	147
Attaching SATA HDDs	147
Configuring system BIOS	148
Creating RAID volumes	149
Configuring SAS RAID devices	150
Supported configurations	150
SAS RAID 0 configuration	151
SAS RAID 1 configuration	152
SAS RAID 1E configuration	153
Deleting RAID volumes	154

8 Configuring password security and resetting CMOS

Preparing to configure passwords	155
Resetting the password jumper	155
Clearing and Resetting the CMOS	156
Using the CMOS Button	156
Using the Computer Setup (F10) Utility to Reset CMOS	157

Appendix A Appendix A—Connector pins

Connector pin descriptions	158
----------------------------------	-----

Appendix B Appendix B—System board designators

Appendix C Appendix C—Routine care

General cleaning safety precautions	170
Cleaning the workstation case	170
Cleaning the keyboard	170
Cleaning the monitor	171
Cleaning the mouse	171

1 Product overview

This chapter presents an overview of the hardware components of the HP xw4600 Workstation, including the following topics:

- [Product features on page 2](#)
- [Workstation specifications on page 7](#)
- [ENERGY STAR Qualification on page 9](#)
- [Dual- and quad-core processors on page 10](#)
- [HP Cool Tools on page 11](#)

See <http://partsurfer.hp.com> for current information on supported spare parts.

Figure 1-2 Workstation components view

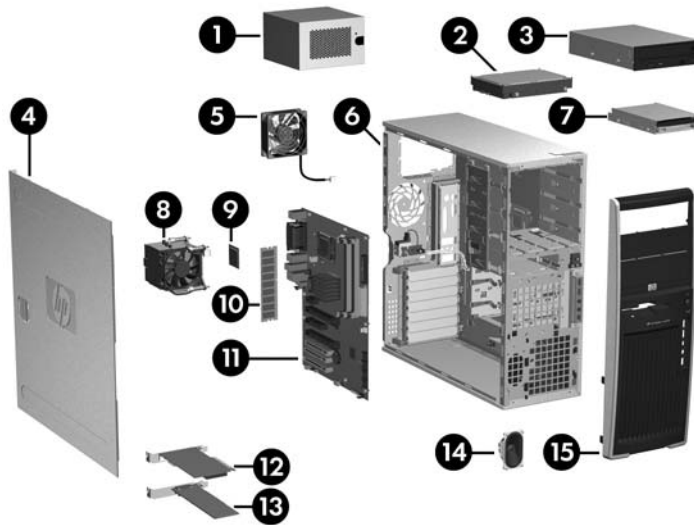

Table 1-1 Component view

Item	Description	Item	Description
1	Power supply	9	Processor
2	Hard drive	10	Memory module
3	Optical drive	11	System board
4	Side access panel	12	PCI Express card
5	System fan	13	PCI card
6	Chassis	14	Speaker
7	Diskette drive	15	Front bezel
8	Processor heatsink		

Front panel components

The following figure shows the front panel components of a typical HP xw4600 Workstation. Drive configurations can vary.

Figure 1-3 Front panel components

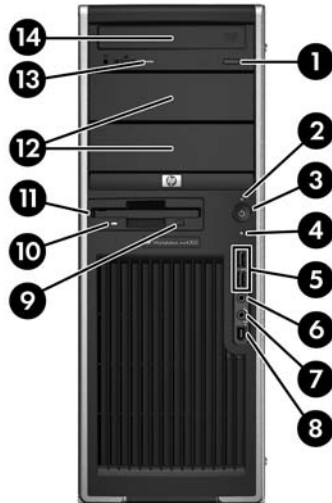







Table 1-2 Front panel components

Item	Symbol	Description	Item	Symbol	Description
1		Optical drive eject button	8		IEEE-1394 Connector (optional)
2		Power on light	9		Diskette drive eject button
3		Power button	10		Diskette drive activity light
4		Hard drive activity light	11		Diskette drive (optional)
5		USB 2.0 (2)	12		5.25-inch drive bays (2)
6		Headphone connector	13		Optical drive activity light
7		Microphone connector	14		Optical drive

Rear panel components

The following figure shows the rear panel components of a typical HP xw4600 Workstation.

Figure 1-4 Rear panel components

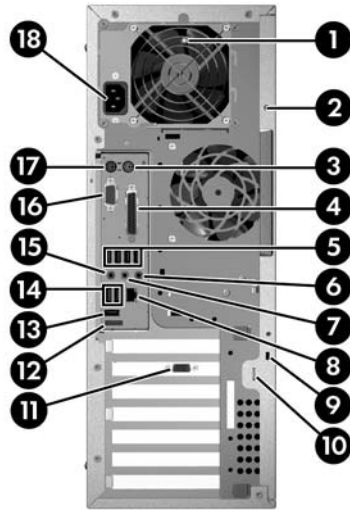













Table 1-3 Rear panel components

Item	Symbol	Description	Item	Symbol	Description
1		Power supply Built-In Self Test (BIST) LED	10		Padlock loop
2		Universal chassis clamp opening	11		Graphics adapter
3		PS/2 mouse connector (green)	12		eSATA adapter
4		Parallel connector (red)	13		USB 2.0 (1)
5		USB 2.0 (4)	14		USB 2.0 (2)
6		Audio line-in connector (blue)	15		Microphone connector (pink)
7		Audio line-out connector (green)	16		Serial connector (blue-green)
8		RJ-45 network connector	17		PS/2 keyboard connector
9		Cable lock slot	18		Power cord connector

 **NOTE:** The rear panel connectors are labeled with industry-standard icons and colors to assist you in connecting your peripheral devices.

Serial number and COA label location

Each workstation has two unique serial number labels (1) and a Certificate of Authentication (COA) label (2) (for Microsoft® Windows® preinstalled systems only). The serial number labels can usually be found on the top panel or on the side or rear of the workstation. Keep this number available when contacting customer service for assistance.

Figure 1-5 Location of serial number and COA label



Maximizing the airflow

- Keep your workstation in an area where the airflow is not obstructed.
- Keep the workstation off of surfaces where dust can gather.
- Keep the front of the workstation clear of any obstruction.
- Remove any dust on the front panel (vent area) and the rear fans with a small vacuum, compressed air, or dust rag.
- Keep the back of the workstation at least 0.15 m (6 in.) away from a wall or other obstruction.

Figure 1-6 Maintain proper clearance

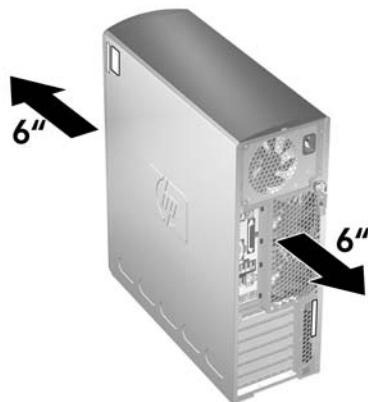

Workstation specifications

The following table lists the physical characteristics of the HP xw4600 Workstation.

Table 1-4 Physical characteristics

Weight (typical configuration)	16 kg (35 lb.)
Tower dimensions	45 cm (17.7 in.) high
	16.8 cm (6.6 in.) wide
	45.6 cm (17.9 in.) deep

Power supply description

The HP xw4600 Workstation includes a 475W, 85% efficient power supply. The power supply is compatible with Energy Star requirements. This section describes the power supply and lists its specifications.

Table 1-5 Power supply source voltages

Source voltage	Description
+3.3V	PCI, PCI Express, audio, CK505, ICH9R, super I/O, BIOS ROM, and onboard logic
+5.1V	Storage (hard drive, optical drive, diskette drive), PCI, PCI Express, ICH9R, audio, keyboard/mouse
+12 V-B	PCI, PCI Express, and system fans
+12 V-D	Storage (hard drive, optical drive, diskette drive), PCI Express x16 auxiliary connector
+12 VCPU	Input to onboard regulator that supplies power to the processor.
-12V	PCI, serial ports
+5 VSB	Sleep circuitry

Table 1-6 Maximum current per rail

Voltage rail	Maximum continuous current
+3.3V	15A
+5.1V	21A
+12 VCPU	17.5A
+12 V-B	17.5A
+12 V-D	18.0A
-12V	0.3A
+5 VSB	2.25A

⚠ **WARNING!** Do not exceed 110W of 5-V and 3.3-V power combination.

Do not exceed 38.0A (456W) of 12V (CPU/B/D) power combination.

Do not exceed 475W of total continuous output power.

Power supply specifications

Table 1-7 Power supply specifications

Item	Description
Power supply	475 watt custom power supply – (Wide Ranging, Active PFC) and 85% efficiency
Operating voltage range	90-269 VAC
Rated voltage range	100-240 VAC 118 VAC
Rated line frequency	50-60 Hz 400 Hz
Operating line frequency range	47-66 Hz 393-407 Hz
Rated input current	10A @ 100-127 VAC 10A @ 118 VAC 6A @ 200-240 VAC
Heat dissipation (Configuration and software dependent)	Typical 954 BTU/hr = (240.3 kg-cal/hr) Maximum 1977 BTU/hr = (498 kg-cal/hr)
Power supply fan	92x25 mm variable speed
ENERGY STAR 5.0 qualified (configuration dependent)	Yes
FEMP Standby Power compliant @115V (<2W in S5 – Power Off)	Yes
Power Consumption in Sleep Mode (as defined by ENERGY STAR)-Suspend to RAM S3 (Instantly available workstation)	< 5W
Built In Self-Test LED	Yes
Surge-tolerant full ranging PSU (Withstands power surges up to 2000V)	Yes

Power consumption and heat dissipation

Power consumption and heat dissipation specifications are available for multiple configurations. To review available specifications, see <http://www.hp.com/go/quickspecs>.

To reach zero power consumption, unplug the workstation from the power outlet or use a power strip with an on/off switch. For additional information about power-saving features, see the operating system installation instructions.

This product is in compliance with U.S. Executive Order 13221.

System fans

This workstation includes one rear system fan, one processor heatsink fan, and one power supply fan. In addition, an optional front system fan is available for special environments, and some graphics cards include onboard fans.

Resetting the power supply

If an overload triggers the power supply overload protection, all power is immediately disconnected. To reset the power supply:

1. Disconnect the power cord from the workstation..
2. Determine what caused the overload and fix the problem. See [System diagnostics and troubleshooting on page 107](#) for troubleshooting information.
3. Reconnect the power cord and reboot the workstation.

When you power off the workstation through the operating system, power consumption falls below what is considered low power consumption, but does not reach zero. This low power consumption feature extends the life of the power supply.

Environmental specifications

This section describes the environmental specifications of your workstation.

Table 1-8 Environmental specifications

Temperature (operating)	5° to 35°C (40° to 95°F)
Temperature (nonoperating)	-40° to 60°C (-40° to 140°F)
Humidity (operating)	8% to 85% RH, noncondensing
Humidity (nonoperating)	8% to 90% RH, noncondensing
Altitude (operating)	0 to 3,048m (10,000 ft)
Altitude (nonoperating)	0 to 9,144m (30,000 ft)
Shock (operating)	1/2-sine: 40G, 2–3 ms
Shock (nonoperating)	1/2-sine: 160 cm/s, 2–3 ms (~100g) Square: 20G, 422 cm/s
	NOTE: Values represent individual shock events and are not indicative of repetitive shock events.
Vibration (operating)	Operating random: 0.5G (rms), 5–300 Hz
Vibration (nonoperating)	Random: 2.0G (rms), 10–500 Hz
	NOTE: Values are not indicative of continuous vibration.

ENERGY STAR Qualification

HP computers marked with the ENERGY STAR logo are compliant with the applicable U.S. Environmental Protection Agency (EPA) ENERGY STAR specifications for computers. The EPA ENERGY STAR logo does not imply endorsement by the EPA. As an ENERGY STAR Partner, Hewlett-Packard Company has determined the products marked with the ENERGY STAR logo are ENERGY

STAR qualified per the applicable ENERGY STAR guidelines for energy efficiency. The following logo appears on all ENERGY STAR qualified computers.



The ENERGY STAR Computers Program was created by the EPA to promote energy efficiency and reduce air pollution through more energy-efficient equipment in homes, offices, and factories. One way products achieve this energy efficiency is by reducing power consumption when not being used through the Microsoft Windows Power Management feature.

The Power Management feature enables the workstation to enter a low-power (or “sleep”) mode after a period of inactivity. When used with an external monitor that is ENERGY STAR qualified, this feature also supports the similar power management features of the external monitor.

To take advantage of this energy savings:

- The Power Management feature has been preset to suspend the workstation to a sleep state after 30 minutes of inactivity.
- The Power Management feature has been preset to suspend the monitor to a sleep state after 15 minutes of inactivity.

Both the computer and monitor can be woken from sleep mode through user interaction with any of the computer input devices (mouse, keyboard, and so on). when configured with Wake On LAN (WOL) enabled, the workstation can also be woken by a network signal.

See the EPA ENERGY STAR Power Management Web site for more information about the energy and financial savings potential of the Power Management Feature: <http://www.energystar.gov/powermanagement>.

See the EPA ENERGY STAR Web site for more information about the ENERGY STAR program and its environmental benefits: <http://www.energystar.gov>.

△ **CAUTION:** Using the Energy Save Monitor feature with monitors that are not ENERGY STAR qualified can cause video distortion when an Energy Save timeout occurs.

📝 **NOTE:** ENERGY STAR is not supported on Linux workstations.

If it is necessary to restore the operating system, you must also reset the ENERGY STAR settings (if applicable) after the restore.

To verify the factory default power settings for your workstation, select **Start>Control Panel**, and then double-click **Power Options**.

Dual- and quad-core processors

The HP xw4600 Workstation supports dual- and quad-core processors that provide two or four true processors in a single socket. Dual- and quad-core processors are better at handling the load of multi-threaded applications (such as rendering images in Digital Content Creation) and highly multi-tasked environments (such as running several productivity applications while listening to music).

HP Cool Tools

HP xw4600 Workstation includes additional software preloaded that is not automatically installed when you first boot your system. Additionally, there are a number of preinstalled tools on your workstation that can enhance your workstation experience. To access or learn more about these applications:

- Open the HP Cool Tools folder by selecting **Start>All Programs>HP Cool Tools**.
- Select the **HP Cool Tools** icon on the desktop.

To learn more about these applications, select **HP Cool Tools—Learn More**.

To install or launch the applications, select the appropriate application.

2 Setting up the operating system

This chapter provides setup and update information for the workstation operating system. It includes these topics:

Topics

[Setting up the Microsoft operating system on page 13](#)

[Setting up Red Hat Enterprise Linux on page 14](#)

[Setting up Novell SLED on page 15](#)

[Updating the workstation on page 15](#)

This chapter also includes information on how to determine that you have the latest BIOS, drivers, and software updates installed on the workstation.

-
- △ **CAUTION:** Do not add optional hardware or third-party devices to the HP workstation until the operating system is successfully installed. Adding hardware might cause errors and prevent the operating system from installing correctly.
-

Setting up the Microsoft operating system

 **NOTE:** If you ordered a downgrade from Windows Vista to Windows XP Professional operating system, your system will be preinstalled with Windows XP Professional operating system. With this configuration, you will receive recovery media for Windows Vista operating system only. In case you need to restore or recover the Windows XP Professional operating system in the future, it is important that you create recovery media disks for Windows XP Professional operating system after first boot.

When you first apply power to the workstation, the operating system is installed. This process takes approximately 5 to 10 minutes. Carefully follow the instructions on the screen to complete the installation.

 **CAUTION:** After installation has started, do *not* turn off the workstation until the process is complete. Turning off the workstation during installation can damage the installation and operation of the software.

For complete operating system installation and configuration instructions, see the operating system documentation that was provided with the workstation. Additional information is available in the online help tool after you successfully install the operating system.

Installing or upgrading device drivers

To install hardware devices after the operating system is installed, you must install the appropriate device drivers before you install the devices. Follow the installation instructions that came with the device. In addition, for optimum performance, your operating system must have the most recent updates, patches, and software fixes. For additional driver and software update information, refer to [Upgrading device drivers on page 17](#).

Transferring files and settings to your Windows workstation

The Microsoft Windows operating system offers data migration tools that helps you choose and transfer files and data from a Windows computer to your Windows Vista or Windows XP Professional operating system workstation.

For instructions on how to use these tools, see the documents at <http://www.microsoft.com>.

Setting up Red Hat Enterprise Linux

HP offers an HP Installer Kit for Linux (HPIKL) to supplement Red Hat box sets and help HP Linux customers customize their system image. The HPIKL contains the HP driver CD and device drivers to successfully setup up the Red Hat Enterprise Linux (RHEL) operating system, The HP Installer Kit for Linux CDs are currently available for download at http://www.hp.com/support/workstation_swdrivers.

Installing with the HP driver CD

To install the HP driver CD, see “Installing with the HP Installer Kit for Linux” in the *HP Workstations for Linux* manual at http://www.hp.com/support/workstation_manuals.

Installing and customizing Red Hat-enabled workstations

Linux-enabled workstations require the HP Installer Kit and the purchase of a Red Hat Enterprise Linux box set. The Installer kit includes the HP CDs necessary to complete the installation of all versions of the Red Hat Enterprise Linux box set that have been qualified to work on an HP workstation.

To use the drivers in the HP Installer kit for Linux other than RHEL, you must manually extract the drivers from the HP Driver CD and install them. HP does not test the installation of these drivers on other Linux distributions nor does HP support this operation.

Verifying hardware compatibility

To see which Linux versions have been qualified to work on HP Workstations visit http://www.hp.com/support/linux_hardware_matrix.

Setting up Novell SLED

To set up the SUSE Linux Enterprise Desktop (SLED) on systems preloaded with the operating system:

1. Boot the workstation.
2. Start the Installation Settings and enter the password, network, graphics, time, keyboard settings, and Novell Customer Center Configuration for the workstation.

 **NOTE:** During Installation Settings after the first time after booting the system the Novell subscription can be activated from the Novell Customer Center Configuration screen. Visit the full Novell Customer Center documentation at <http://www.novell.com/documentation/ncc/>.

Updating the workstation

HP is constantly working on improving your total workstation experience. To ensure that the workstation leverages the latest enhancements, HP recommends that you install the latest BIOS, driver, and software updates on a regular basis.

Updating the workstation after first boot

After successfully booting the workstation for the first time, you should follow these guidelines to ensure that the workstation is up-to-date:

- Ensure that you have the latest system BIOS loaded. See [Upgrading the BIOS on page 15](#) for instructions.
- Ensure that you have the latest drivers for your system. See [Upgrading device drivers on page 17](#) for instructions.
- Become familiar with your available HP resources.
- Consider a subscription to Driver Alerts at <http://www.hp.com/go/subscriberschoice>.

Upgrading the BIOS

For optimum performance, determine the BIOS revision on the workstation, and upgrade it if necessary.

Determining current BIOS

To determine the current BIOS of the workstation during system power up:

1. Wait for F10=setup to appear on the lower right corner of the screen.
2. Press **F10** to enter the F10 Setup utility.

The F10 Setup utility displays the workstation BIOS version under **File > System Information**.

3. Note the workstation BIOS version so that you can compare it with the BIOS versions that appear on the HP website.

Upgrading BIOS

To find and download the latest available BIOS, which includes the latest enhancements:

1. Go to <http://www.hp.com/go/workstationsupport>.
2. Select **Download Drivers and Software** from the left menu column under Tasks.
3. Follow the instructions to locate the latest BIOS available for the workstation.
4. If the BIOS on the Web site is the same as the version on your system, no further action is required.
5. If the BIOS on the Web site is a version later than the one on your system, download the appropriate version for the workstation. Follow the instructions in the release notes to complete the installation.

Upgrading device drivers

If you install a peripheral device (such as a printer, display adapter, or network adapter), confirm you have the latest device drivers loaded. If you purchased your device through HP, visit the HP Web site to download the latest drivers for your device. These drivers have been tested to ensure the best compatibility between your device and your HP workstation.

If you did not purchase your device from HP, HP recommends visiting the HP Web site first to see if your device and its drivers have been tested for HP workstation compatibility. If no driver is available, visit the device manufacturer's Web site to download the latest drivers.

To upgrade device drivers:

1. Go to <http://www.hp.com/go/workstationsupport>.
2. Select **Download Drivers and Software** from the left menu column under Tasks.
3. Follow the instructions to find the latest drivers available for the workstation.

If a needed driver is not found, see the Web site of the manufacturer of the peripheral device.

3 Restoring the operating system

This chapter describes how to restore the Windows or Linux operating system. It includes these topics:

Topics

[Restore methods on page 18](#)

[Ordering backup software on page 19](#)

[Restoring Windows Vista on page 19](#)

[Restoring Windows XP Professional on page 20](#)

[Restoring Novell SLED on page 22](#)

Restore methods

The Windows Business Vista operating system can be reinstalled using the HP RestorePlus! process. The Windows XP Professional operating system can be reinstalled using the RestorePlus! process or the HP Backup and Recovery Manager.

- RestorePlus!

The RestorePlus! process reinstalls the Windows operating system and device drivers (for devices included with the system) to a near-factory state. The process does not back up or recover data on the hard drive. Some application software might not be restored using this process and must be installed from the appropriate application CD.

- HP Backup and Recovery Manager (HPBR) Recovery Point

The HP Backup and Recovery Manager application can be used to capture and restore the contents of the system partition. It captures a snapshot of the system partition and stores it in a Recovery Point. Everything on the system partition at the time the recovery point was made is saved.

 **NOTE:** HP Backup and Restore is only supported on the HP xw6600 and xw8600 Workstations.

The Recovery Point is saved to the hard drive and can be burned to media for safekeeping.

△ **CAUTION:** These methods restore the operating system, but not data. Data must be backed up regularly to avoid loss.

Ordering backup software

If you cannot create system recovery CDs or DVDs, you can order a recovery disk set from the HP support center. To obtain the support center telephone number for your region see <http://www.hp.com/support/contactHP>.

Restoring Windows Vista

This section describes how to restore Windows Vista.

Ordering the RestorePlus! media

If you ordered restore media with your workstation, the media is included with your workstation components.

If you did not order restore media, call HP Support and request a RestorePlus! media kit. For worldwide technical support phone numbers, see <http://www.hp.com/support>.

Restoring the operating system

 **NOTE:** Windows Vista provides a backup and restore application as well. To learn more about this application, see the Microsoft Web site.

 **CAUTION:** Before you restore the operating system, back up your data.

When you run RestorePlus! from media, the process deletes all information on the primary hard drive, including all partitions.

To restore Windows Vista:

1. Boot from the RestorePlus! DVD to start the RestorePlus! process. You must start from the RestorePlus! DVD to install device drivers and settings.
2. Follow the prompts to restore your operating system.

Some application software might not be restored using this process. If software is not restored, install it from the appropriate application DVD.

Restoring Windows XP Professional

This section describes how to restore the Windows XP Professional operating system.

 **NOTE:** The workstation must have a CD or DVD writer installed to create the media set.

Creating RestorePlus! media

The RestorePlus! kit can be created using the files contained on the hard drive. To create the restore media:

1. Boot the workstation.
2. During boot up, an HP Backup and Recovery Manager screen is displayed prompting you to create Recovery CDs or DVDs. Select **Now**.
3. An Initial Recovery Point (IRP) of the system is captured. This is a snapshot of the system hard drive. The capture can take more than 10 minutes.
4. After the IRP is created, you can create a set of backup CDs or DVDs.

To create a RestorePlus! media set including the Windows XP operating system CD, select **RestorePlus! > Microsoft Windows XP operating system > Supplemental media**.

 **NOTE:** Depending on the options, there might be additional DVDs you can create.

5. Follow the prompts to create RestorePlus!, operating system, and HPBR media.

If you are unable to create CD/DVDs on your workstation, call HP Support and request a RestorePlus! media kit. For worldwide technical support phone numbers, see <http://www.hp.com/support>.

Creating HP Backup and Recovery (HPBR) media

 **NOTE:** HPBR is only supported on Windows XP systems. For details, refer to the documentation on the Supplemental Software - *HP Backup and Recovery* CD included with the workstation. The documentation can be accessed during installation.

The Initial Recovery Point can be burned to optical media and used to recover a system. This section describes making the media.

 **NOTE:** The workstation must have a CD or DVD writer to create the media set.

To create HPBR recovery media:

1. The Initial Recovery Point was captured when the RestorePlus! media set was created previously.
If the IRP was not created, start the HP Backup and Recovery Manager and create recovery points using the Expert mode. Follow the HPBR online documentation for instructions.
2. Burn the IRP to media from HPBR.
Select **HPBR Start > All Programs > HP Backup & Recovery > HP Backup and Recovery Manager**.
3. Select **Next** at the first screen.
Select **Create recovery CDs or DVDs to recover the system**, and then select **Next**.
4. Choose **Next** to display a list of available CD image and the recovery points.
5. Check the box next to Initial Recovery Point, and then select **Next**.
6. Follow the instructions to create the media.

Restoring the operating system

△ **CAUTION:** Before you restore the operating system, back up your data.

When you run RestorePlus! from media, the process deletes all information on the primary hard drive, including all partitions. If you run RestorePlus! from the recovery partition, only the root (C:) partition is affected.

Using RestorePlus!

To restore with RestorePlus!:

1. Boot the workstation from the RestorePlus! DVD. You must start from the RestorePlus! DVD for device drivers and settings to be installed.
2. Follow the prompts to restore the operating system.

Some application software might not be restored using this process. If software is not restored, install it from the appropriate application DVD.

Using HPBR

To restore with the HPBR Initial Recovery Point media:

1. Boot the workstation from the Initial Recovery Point media.
2. Follow the prompts to restore the system to the state when the IRP was created.

Using the recovery partition

A system that shipped with Windows XP includes a recovery partition. You can boot the system from that recovery partition.

From the recovery partition you can perform a system restore using the HPBR Initial Recovery Point, if it was created. If it was not, you can use a RestorePlus! install.

To restore using the recovery partition:

1. Boot the workstation.
2. When prompted on the boot screen to enter the Recovery Manager, press **F11**.

💡 **TIP:** The opportunity to press F11 during the boot process is small. It comes about the time the F10 prompt appears.

📄 **NOTE:** To ensure that the recovery processes reinstall on the correct hard drive, do not disconnect the target drive during the recovery process.

3. Follow the prompts to restore the system to factory-like condition.

Restoring Novell SLED

The SLED restore media is required to restore the Linux operating system.

Creating restore media

THE SUSE Linux Enterprise Desktop preload includes a SUSE ISO icon on the desktop. You can click this icon to go to the `/iso` directory. The `/iso` directory contains all iso images used to preload your workstation. To recover or restore the original image, follow the instructions in the readme file in the `/iso` directory to copy the ISO image file onto CDs.

 **NOTE:** Make copies of the ISO recovery images on CD as backup files in case your workstation experiences a hard drive failure.

4 System management

This section describes the various tools and utilities that provide system management for your workstation and includes the following topics:

Topics

[Computer Setup \(F10\) Utility on page 24](#)

[Workstation management on page 33](#)

Computer Setup (F10) Utility

The Computer Setup (F10) Utility enables you to:

- Change factory default settings and set or change the system configuration, which might be necessary when you add or remove hardware.
- Determine if all of the devices installed on the workstation are recognized by the system and functioning properly.
- Determine information about the operating environment of the workstation.
- Solve system configuration errors that are detected but not automatically fixed during the Power-On Self-Test (POST).
- Establish and manage passwords and other security features.
- Establish and manage energy-saving time-outs (not supported on Linux platforms).
- Modify or restore factory default settings.
- Set the system date and time.
- Set, view, change, or verify the system configuration, including settings for processor, graphics, memory, audio, storage, communications, and input devices.
- Modify the boot order of installed mass storage devices such as SATA, SAS, diskette drives, optical drives, network drives, and LS-120 drives.
- Configure the boot priority of SATA and SAS hard-drive controllers.
- Enable or disable Network Server Mode, that enables the workstation to boot the operating system when the power-on password is enabled with or without a keyboard or mouse attached. When attached to the system, the keyboard and mouse remain locked until the power-on password is entered.
- Select POST Messages Enabled or Disabled to change the display status of POST messages. POST Messages suppresses most POST messages, such as memory count, product name, and other non-error text messages. If a POST error occurs, the error is displayed regardless of the mode selected. To manually switch to POST Messages Enabled during POST, press any key except **F1** through **F12**.
- Establish an Ownership Tag, the text of which is displayed each time the system is powered on or restarted.

- Enter the Asset Tag or property identification number assigned by your company to this workstation.
- Enable power-on password prompts during system restarts (warm-boots) and power on.
- Hide or show the integrated I/O functionality, including serial, USB, or parallel ports, audio, or embedded NIC. Any hidden devices are inaccessible which increases overall system security.
- Enable or disable removable media boot ability.
- Enable or disable removable media write ability (if supported by hardware).
- Replicate your system setup by saving system configuration information on CD or diskette and restoring it on one or more workstations.
- Execute self-tests on specified SATA and SAS hard drives (if supported by the drive).

BIOS ROM

The BIOS ROM is a collection of machine language programs stored as firmware in ROM. It includes functions such as POST, PCI device initialization, Plug and Play support, power management, and the Computer Setup (F10) Utility. The BIOS ROM is a 1-MB Serial Peripheral Interface (SPI) port. The firmware contained in the BIOS ROM supports the following systems and specifications:

- Microsoft Windows Hardware Quality Labs (WHQL)
- Alert-On-LAN (AOL) and Wake-On-LAN (WOL)
- Advanced Configuration and Power Interface (ACPI) 1.0 and OnNow
- System Management BIOS (SMBIOS) 2.3.5
- PC98/99/00 and NetPC
- Preboot Execution Environment (PXE) boot ROM for the integrated LAN controller
- BIOS Boot Specification 1.01
- Enhanced Disk Drive Specification 3.0
- “El Torito” Bootable CD Format Specification 1.0
- AT Attachment Packet Interface (ATAPI) Removable Media Device BIOS Specification 1.0
- Multiprocessor Specification (MPS) 1.4 (for booting Linux SMP)

Using the Computer Setup (F10) Utility

You can only open the Computer Setup (F10) Utility by powering on or restarting the workstation.

To access the Computer Setup (F10) Utility menu:

1. Power on or restart the workstation.
2. As soon as your display is active and **F10=Setup** appears in the lower right corner of the screen, press the **F10** key .

 **NOTE:** If you do not press **F10** at the appropriate time, try again. Turn the workstation off, then on, and press **F10** again to access the utility. You can also press the **Ctrl + Alt + Delete** keys before boot if you miss the opportunity to press **F10**.

3. Select your language from the list and press the **Enter** key. In the Computer Setup (F10) Utility menu, five headings are displayed: **File**, **Storage**, **Security**, **Power**, and **Advanced**.
4. Use the left and right arrow keys to select the appropriate heading. Use the up and down arrow keys to select an option, and then press **Enter**.
5. To apply and save changes, select **File>Save Changes**, and then select **F10=YES**.
 - If you have made changes that you do not want applied, select **Ignore Changes** and then select **F10=YES**.
 - To reset to factory settings, select **File>Default setup>Restore Factory Settings as Default**. Press **F10** to accept the changes. Select **Apply Defaults and Exit**. This option restores the original factory system defaults.

△ **CAUTION:** Do not power off the workstation while the ROM is saving your Computer Setup (F10) Utility changes because the Complementary Metal-Oxide Semiconductor (CMOS) could become corrupted. After you exit the F10 Setup screen, it is safe to disconnect power from the workstation.

Computer Setup (F10) Utility menu



NOTE: With new BIOS releases, the following content is subject to change, so your menu might appear different than shown.

Table 4-1 Computer Setup (F10) Utility menu descriptions

Heading	Option	Description	
File	System Information	<ul style="list-style-type: none"> Product Name SKU Number Processor Type/Speed/Stepping Cache Size (L1/L2) Installed Memory Size Integrated MAC System BIOS Chassis Serial Number Asset Tracking Number 	
		About	Displays copyright information.
		Set Time and Date	Enables you to set system time and date.
		Flash System ROM	CD-ROM—Enables you to upgrade the BIOS from a ROM image on a CD.
			USB—Enables you to upgrade the BIOS from a ROM image on a USB drive or memory stick.
		Replicated Setup	Save to Removable Media—Saves the system configuration, including CMOS, in the qsetup.txt file. This file can be saved to a formatted, blank 1.44-MB diskette, or to a USB device.
			Restore from Removable Media—Restores the system configuration from a diskette.
		Default Setup	Save Current Settings as Default—Saves the current settings as default settings for the next operation.
	Restore Factory Settings as Default—Restores the factory settings as the default settings for the next operation.		
	Apply Defaults and Exit	Restores factory default settings.	
Ignore Changes and Exit	Exits computer setup without applying or saving any changes.		
Save Changes and Exit	Saves changes to system configuration and exits the computer setup.		
Storage	Device Configuration	Lists all installed nonSCSI storage devices (except SATA devices) and provides options for obtaining specific information about each device.	
		Hard Disk—Provides information about the hard disk drives in the system.	
		CD-ROM—Provides information about the optical drives in the system.	
		Diskette Type (for legacy diskette drives only)—Identifies the highest capacity media type accepted by the diskette drive. Options are 3.5" (1.44 MB), 5.25" (1.2 MB), and Not Installed.	
		Default Values—Resets devices to their default configuration (SATA is the default).	

Table 4-1 Computer Setup (F10) Utility menu descriptions (continued)

Heading	Option	Description
		<p>Multisector Transfers options are 8, 16, and Disable (16 is the default).</p> <p>Transfer Mode specifies the active data transfer mode. Options (which are subject to device capabilities) are: Max UDMA, PIO 0, Max PIO, Enhanced DMA, and Ultra DMA0 (Max UDMA is the default).</p> <p>Translation Mode enables the BIOS to automatically determine the translation mode used to configure a previously formatted SATA or USB mass storage device. This prevents you from having to know how the mass storage device was previously formatted.</p> <p>Ordinarily, the translation mode selected automatically by the BIOS should not be changed. If the selected translation mode is not compatible with the translation mode that was active when the drive was partitioned and formatted, the data on the disk is inaccessible.</p> <p>Translation Mode Options are: Automatic, Bit Shift, LBA Assisted, Use (Cylinders, Heads, Sectors), and Off (Automatic is default).</p>
	Storage Options	<p>Removable Media Boot—Enables and disables the ability to boot the system from removable media.</p> <p>Legacy Diskette Write—Enables and disables the ability to write data to removable media.</p> <p>SATA Emulation—Sets the SATA emulation mode with the following options:</p> <ul style="list-style-type: none"> RAID—RAID OPROM executes. This emulation mode offers the best performance and most functionality. IDE—Offers standard SATA support (four ports only). AHCI—Offers full SATA and SATA-II functionality with no support for RAID.
	DPS Self-test	<p>Enables you to select a drive test for a SATA drive. It is not displayed by default and not available for RAID and AHCI configurations.</p>
	Boot Order	<p>Enables you to configure the boot, diskette drive, and hard drive orders by physically reordering the menu entries. The default boot order presents the following selections:</p> <ul style="list-style-type: none"> Optical Drive Diskette Drive USB Device Hard Drive Broadcom Ethernet controller <p>Press Enter to drag a device to a preferred place. Press F5 to remove the device from consideration as a bootable device.</p> <p>NOTE: MS-DOS drive lettering assignments might not apply after an operating system other than MS-DOS has started.</p> <p>Boot devices can be disabled in the boot order process. These order changes are stored in the physical ROM when the F10 Setup changes are confirmed with File>Save Changes and Exit.</p> <p>You can temporarily override the boot order:</p> <p>To boot one time from a device other than the default device specified in Boot Order, restart the workstation and press F9 when the F9=Boot Menu message appears on the screen. After POST completes, a list of bootable devices is displayed. Use the arrow keys to select the preferred bootable device and press Enter. The workstation then boots from the selected nondefault device this time only.</p>
Security	Setup Password	<p>Enables you to set and enable setup (administrator) password.</p> <p>NOTE: If the setup password is set, it is required to change computer setup options, flash the ROM, and make changes to certain Plug and Play settings under Windows.</p>

Table 4-1 Computer Setup (F10) Utility menu descriptions (continued)

Heading	Option	Description
	Power-On Password	Enables you to set and enable the power-on password.
	Password Options	<p>Lock Legacy Resources—Prevents the operating system from changing resources to Serial, Parallel, and Diskette controller.</p> <p>Setup Browse Mode—If a setup password is created, this mode enables read-only access to the F10 Setup menu for users without a password.</p>
	Smart Cover	Allows you to disable the cover removal sensor or to notify you if the sensor has been activated.
	Device Security	<p>Makes the following devices available or unavailable to the system:</p> <ul style="list-style-type: none"> • Serial port • Parallel port • Front USB port • Rear USB port • Internal USB port • System audio • Network controller • Legacy diskette • Embedded Security Device • SATA0–5 <p>For each device, Device Available is the default setting and allows the operating system to access the device. Device Hidden makes the device unavailable; it is disabled by the BIOS and cannot be enabled by the operating system. When enabled, Embedded Security Device offers these options:</p> <ul style="list-style-type: none"> • Embedded Security Device Support • Enable/Disable—Turns the Trusted Platform Mechanism (TPM) on and off. If this option is enabled, the following options become available: <ul style="list-style-type: none"> ◦ Power-On Authentication Support—Enables and disables an authentication feature that requires you to enter a TPM user key password to boot the system. This feature uses the TPM to generate and store the authentication password. ◦ Reset Authentication Credential—Resets the authentication functionality and clears all authentication credentials. <p>NOTE: A setup password must be set to enable the Embedded Security Device and to access any security features associated with the Embedded Security Device.</p>
	Network Service Boot	Enables or disables the ability to boot to the network using the F12 key or the boot order.
	System IDs	<p>Asset Tag—A 16-byte string identifying the system.</p> <p>Ownership Tag—An 80-byte string identifying ownership of the system. This tag is displayed on the screen during POST.</p> <p>Universal Unique Identifier (UUID)—Can only be updated if the current chassis serial number is invalid. (These ID numbers are normally set in the factory and are used to uniquely identify the system.)</p> <p>Keyboard—Enables you to set the keyboard locale for System ID entry.</p>

Table 4-1 Computer Setup (F10) Utility menu descriptions (continued)

Heading	Option	Description
	DriveLock Security	Allows you to select a hard drive, enable or disable DriveLock security on that drive, and set a DriveLock password. This option appears only if your drive supports DriveLock. CAUTION: Enabling DriveLock can render a hard drive permanently inaccessible if the master password is lost or forgotten. No method exists to recover the password or access the data.
	System Security	Data Execution Prevention—Enables or disables Data Execution Prevention mode in the processors. This mode prohibits code from running in pages that were set up as data pages, and prevents attacks such as buffer overflows. Operating system support is required for this feature. Virtualization Technology (VTx)—Enables Intel Virtualization Technology to increase workstation performance. (This feature is not available in all configurations.) Virtualization Technology Directed
		OS Management of Embedded Security Device—Enables or disables the ability of the operating system to control the TPM device, including turning it on and off, initializing it, and resetting it.
		Reset of Embedded Security Device through OS—Enables or disables the ability of the operating system to reset the TPM.
	Setup Security Level	Enables the administrator to selectively set the security level for each setup feature. The options are: Setup Password and None. Browser mode must be enabled to use this option.
Power	OS Power Management	Enables or disables: <ul style="list-style-type: none"> • Runtime Power Management • ACPI S3 Hard Disk Reset • ACPI S3 PS 2 Mouse Wakeup • USB Wake on Device Insertion • Unique Sleep State Blink Rates
	Hardware Power Management	Enables or disables SATA Power Management
	Thermal	Enables you set the rate of the system fan when the processor is in idle.

Table 4-1 Computer Setup (F10) Utility menu descriptions (continued)

Heading	Option	Description
Advanced**	Power-On Options	<p>Allows you to set:</p> <ul style="list-style-type: none"> • POST Mode (QuickBoot, FullBoot, or FullBoot every 1–30 days). • POST Messages (Enable or Disable). • F9 Prompt (Enable or Disable). Enabling this feature displays F9=Boot Menu during POST. Disabling this feature prevents the text from being displayed. However, pressing the F9 key still accesses the boot menu. • F10 Prompt (Enable or Disable)—Enabling this feature displays F10=Setup during POST. Disabling this feature prevents the text from being displayed, but pressing F10 still accesses the Setup screen. • F11 Prompt (Enable or Disable)—Makes the Factory Recovery option visible during POST. Disabling this feature prevents the text from being displayed, but pressing F10 still accesses the Setup screen. Factory Recovery Boot Support must be enabled to use this option. • F12 Prompt (Enable or Disable)—Enabling this feature displays F12=Network Service Boot during POST. Disabling this feature prevents the text from being displayed but pressing F12 still forces the system to attempt booting from the network. • Factory Recovery Boot Support (Enable or Disable)—Recovery partition hard disk drive (HDD) option available. Vista leaves the factory with this support in place. • Option ROM prompt* (Enable or Disable)—Enabling this feature causes the system to display a message before loading options ROMs. • Remote Wakeup Boot Source • After Power Loss (On or Off)—Enabling this option directs the previous state to be the default. • POST Delay (in seconds) (Enable or Disable)—Enabling this feature adds a user-specified delay to the POST process. This delay is sometimes needed for hard drives on some PCI cards that spin up slowly (so slowly that they are not ready to boot by the time POST is finished). The POST delay also gives you more time to select F10 to enter the Computer Setup (F10) Utility. • Limit (CPUID Maximum Value to 3) (Enable/Disable)
	Execute Memory Test	Tests workstation memory. The workstation reboots, and any changes that have been made are lost. The workstation might boot with memory in a sub optimal configuration.
	BIOS Power-On	Enables you to disable or specify a weekday and time for BIOS power-on.
	Onboard Devices	Enables you to set resources for or disable onboard system devices such as serial ports, parallel ports, and diskette controllers. Operating system parameters generally override Onboard Devices settings.
	PCI Devices	<p>Enables you to set the IRQ for or disable the following devices during POST:</p> <ul style="list-style-type: none"> • Intel USB controllers • Intel HD audio device • Intel RAID controller • nVidia VGA controller • Broadcom Ethernet controller <p>Operating system parameters generally override PCI Devices settings.</p> <p>Available IRQ values are 5, 10, and 11.</p>

Table 4-1 Computer Setup (F10) Utility menu descriptions (continued)

Heading	Option	Description
	Bus Options	The options are: <ul style="list-style-type: none">• PCI SERR# Generation (Enable/Disable)• PCI VGA Palette Snooping (Enable/Disable)• ECC Support (Enable/Disable)
	Device Options	<ul style="list-style-type: none">• Printer Mode (EPP + ECP, Output-Only, Bi-Directional)• Num Lock State at Power-On (On or Off)• S5 Wake-on-LAN (Enable or Disable)• Multi-Processor-Turns multi-core function to single-core• Internal Speaker (Enable or Disable)• Monitor Tracking (Enable or Disable)• NIC PxE Option ROM Download (Enable or Disable)• SATA RAID Option ROM Download (Enable or Disable)
	Slot 1 (PCI Express x 1)	Slot 1 option ROM download (Enable/Disable)
	Slot 2 (PCI Express x16)	Slot 2 option ROM download (Enable/Disable) and latency timer.
	Slot 3 (PCI Express 4)	Slot 3 option ROM download (Enable/Disable).
	Slot 4 (PCI Express x16)	Slot 4 option ROM download (Enable/Disable).
	Slot 5 (PCI)	Slot 5 option ROM download (Enable/Disable) and latency timer.
	Slot 6 (PCI)	Slot 6 option ROM download (Enable/Disable) and latency timer.
	Slot 7 (PCI)	Slot 7 option ROM download (Enable/Disable) and latency timer.

* Available on selected models.

**These options should be used by advanced users only.

Workstation management

The HP Client Management Solutions (CMS) which are available for download from <http://www.hp.com/go/easydeploy> are standards-based solutions for managing and controlling workstations in a networked environment. This section summarizes capabilities, features, and key components of workstation management including:

Topics

[Initial workstation configuration and deployment on page 34](#)

[Installing a remote system on page 34](#)

[Replicating the setup on page 34](#)

[Updating and managing software on page 37](#)

[ROM Flash on page 39](#)

[FailSafe Boot Block ROM on page 40](#)

[Asset tracking and security on page 41](#)

[Fault notification and recovery on page 49](#)

[Dual-state power button on page 50](#)



NOTE: Support for specific features described in this guide can vary by model and software version.

Initial workstation configuration and deployment

Your workstation includes a preinstalled system software image. After a brief software unbundling process, the workstation is ready to use.

If you prefer to replace the preinstalled software image with a customized set of system and application software, several methods are available for deploying a customized software image, including:

- Installing additional software applications after unbundling the preinstalled software image
- Using a disk cloning process to copy the contents from one hard drive to another

The best deployment method depends on your information technology environment and processes.

The Restore Plus! CD, ROM-based setup, and ACPI hardware provide further assistance with recovery of system software, configuration management and troubleshooting, and power management.

Installing a remote system

Remote system installation enables you to start and set up your system using the software and configuration information located on a network server. This feature is usually used as a system setup and configuration tool and can be used for the following tasks:

- Deploying a software image on one or more new PCs
- Formatting a hard drive
- Installing application software or drivers
- Updating the operating system, application software, or drivers

To initiate a remote system installation, press **F12** when **F12=Network Service Boot** appears in the lower right corner of the HP logo screen. Follow the onscreen instructions to continue the installation process. The default boot order is a BIOS configuration setting that can be changed to always attempt a PXE boot.

Replicating the setup

The following procedures enable you to copy one setup configuration to other workstations of the same model for faster, more consistent configuration of multiple workstations. Both procedures require a diskette drive or a USB device such as an HP Drive Key.

Copying a setup configuration to a single workstation

△ **CAUTION:** A setup configuration is model-specific. File system corruption can result if source and target workstations are not the same model. For example, do not copy the setup configuration from an HP xw4200 Workstation to an HP xw4600 Workstation.

1. Select a setup configuration to copy, and then reboot the workstation.
2. As soon as the workstation powers on, press and hold the **F10** key until you enter the Computer Setup (F10) Utility. If necessary, press **Enter** to bypass the title screen.

 **NOTE:** If you do not press the **F10** key at the appropriate time, you must restart the workstation, and then press and hold the **F10** key again to access the utility.

If you are using a PS 2 keyboard, you may see a keyboard error message—disregard it.

3. If you are using a diskette or other storage device, insert it now. If not, proceed to the next step.
4. Select **File>Replicated Setup>Save to Removable Media**. Follow the instructions on the screen to create the configuration diskette.
5. Power off the workstation you are configuring and insert the configuration diskette into the diskette drive.
6. Power on the workstation you are configuring.
7. Press and hold the **F10** key until you enter the Computer Setup (F10) Utility. If necessary, press **Enter** to bypass the title screen.
8. Select **File>Replicated Setup>Restore from Removable Media**, and then follow the instructions on the screen.
9. Restart the workstation when the configuration is complete.

Copying a setup configuration to multiple workstations

 **CAUTION:** A setup configuration is model-specific. If source and target workstations are not the same model, file system corruption can result. For example, do not copy the setup configuration from an HP xw4200 Workstation to an HP xw4600 Workstation.

This method takes a little longer to prepare the configuration diskette, but copying the configuration to target workstations is fast.

 **NOTE:** A bootable diskette is required for this procedure. If Windows XP is not available to create a bootable diskette, use the method for copying to a single workstation instead (see [Copying a setup configuration to a single workstation on page 35.](#))

1. Create a bootable diskette.
2. Select a setup configuration to copy.
3. Restart the workstation.
4. As soon as the workstation powers on, press and hold the **F10** key until you enter the Computer Setup (F10) Utility. If necessary, press **Enter** to bypass the title screen.

 **NOTE:** If you do not press the **F10** key at the appropriate time, you must restart the workstation, and then press and hold the **F10** key again to access the utility.

If you are using a PS 2 keyboard, you might see a keyboard error message—disregard it.

5. If you are using a diskette or other storage device, insert it now. If not, proceed to the next step.
6. Select **File>Replicated Setup>Save to Removable Media**. Follow the instructions on the screen to create the configuration diskette.
7. Download a BIOS utility for replicating setup (repset.exe) and copy it to the configuration diskette. To obtain this utility, see <http://www.hp.com/support/files>. Enter the model number of the workstation.
8. On the configuration diskette, create an autoexec.bat file containing `repset.exe` and `cpqsetup.txt`.
9. Power off the workstation you are configuring. Insert the configuration diskette, and then power on the workstation. The configuration utility runs automatically.
10. Restart the workstation when the configuration is complete.

Updating and managing software

HP provides several tools for managing and updating software on desktops and workstations: HP Client Manager Software, Altiris Client Management Solutions, System Software Manager, Proactive Change Notification, and Subscriber's Choice.

HP Client Manager Software

HP Client Manager Software (HP CMS) assists customers in managing workstation hardware. It offers:

- Detailed views of hardware inventory for asset management
- PC health-check monitoring and diagnostics
- Proactive notification of changes in the hardware environment
- Web-accessible reporting of business-critical details such as thermal warnings, memory alerts, and more
- Remote updating of system software such as device drivers and ROM BIOS
- Remote changing of boot order
- Configuration of system BIOS settings

For more information about the HP Client Manager, see <http://www.hp.com/go/ssm>.

Altiris Client Management Solutions

Altiris and HP have partnered to provide comprehensive, tightly integrated systems management solutions to reduce the cost of owning HP client PCs. The HP Client Manager Software is the foundation for additional Altiris Client Management Solutions that address:

- Inventory and asset management
- Deployment and migration
- Help desk and problem resolution
- Software and operations management

For more information about the following topics, go to <http://www.hp.com/go/ssm>:

- How HP Client Manager Software works
- Which solutions are compatible with your operating system
- How to download a fully functional, 30-day evaluation version of Altiris solutions

System Software Manager

System Software Manager (SSM) is a utility that enables you to update system-level software on multiple systems simultaneously. When executed on a PC client system, SSM detects both hardware and software versions, and then updates the appropriate software from a central repository, also known as a *file store*. Driver versions that are supported by SSM are denoted with a special icon on the software, the driver download Web site, and on the Support Software CD. To download the utility or to obtain more information about SSM, see <http://www.hp.com/go/ssm>.

Proactive Change Notification

The Proactive Change Notification program uses the Subscriber's Choice Web site to proactively and automatically:

- Send you Proactive Change Notification (PCN) emails informing you up to 60 days in advance about hardware and software changes to most commercial workstations and servers
- Send you e-mails containing customer bulletins, customer advisories, customer notes, and driver alerts for most commercial workstations and servers

You can create your own profile to ensure that you only receive the information relevant to your specific IT environment. To learn more about the PCN program and to create a custom profile, see [Subscriber's Choice on page 38](#).

Subscriber's Choice

Subscriber's Choice is a client-based service from HP that supplies you with personalized product tips, feature articles, and driver and support alerts and notifications based on your individual profile.

Subscriber's Choice Driver and Support Alerts and Notifications delivers email notifying you that the information you subscribed to in your profile is available for review and retrieval. To learn more about Subscriber's Choice and create a custom profile, see <http://www.hp.com/united-states/subscribe/gateway/>.

ROM Flash

Your HP workstation comes with a programmable flash ROM. By establishing a setup password in the Computer Setup (F10) Utility, you can protect the ROM from being inadvertently updated or overwritten. This function is important to ensure the operating integrity of the workstation. To upgrade the ROM, download the latest SoftPaq images from <http://www.hp.com/support/files>.

 **NOTE:** For maximum ROM protection, be sure to establish a setup password. The setup password prevents unauthorized ROM upgrades. System Software Manager enables you to create the setup password on one or more workstations simultaneously. For more information, see <http://www.hp.com/go/ssm>.

Remote ROM Flash

Remote ROM Flash allows system administrators to safely upgrade the ROM on remote HP workstations directly from a centralized network management console, resulting in a consistent deployment of, and greater control over, HP PC ROM images over the network.

To use Remote ROM Flash, the workstation must be powered on, or turned on using Remote Wakeup.

For more information about Remote ROM Flash, see the HP Client Manager Software or System Software Manager sections at <http://www.hp.com/go/ssm>.

HPQFlash

The HPQFlash utility is used to locally update or restore the system ROM on individual PCs through a Windows operating system.

For more information about HPQFlash, see <http://www.hp.com/go/ssm>, and enter the name of your workstation.

FailSafe Boot Block ROM

The FailSafe Boot Block ROM enables system recovery in the unlikely event of a ROM flash failure. For example, if a power failure occurs during a ROM upgrade, the Boot Block uses a flash-protected section of the ROM to check for a valid system ROM flash when power to the system is restored.

- If the system ROM is valid, the system starts normally.
- If the system ROM fails the validation check, the FailSafe Boot Block ROM provides enough support to start the system from a BIOS image CD created from a SoftPaq. The BIOS image CD programs the system ROM with a valid image.

When Boot Block detects an invalid system ROM, the workstation power LED blinks red eight times and beeps eight times, then the workstation pauses for two seconds. Also, eight simultaneous beeps will be heard. A Boot Block recovery mode message is displayed on the screen (some models).

In preparation for system recovery, use the BIOS CD media file in the SoftPaq to create a BIOS image CD.

To recover the system after it enters Boot Block recovery mode:

1. If there is media in the diskette or optical drives, remove it.
2. Insert a BIOS image CD into the CD drive. USB media (such as an HP DriveKey) can also be used.
3. Power off, then power on the workstation.

If no BIOS image CD or USB is found, you are prompted to insert one and restart the workstation.

If a setup password has been established, the Caps Lock light illuminates and you are prompted for the password.

4. Enter the setup password.

If the system successfully starts from the CD or USB and successfully reprograms the ROM, then the three keyboard lights illuminate. A rising-tone series of beeps also signals successful recovery.

5. Remove the CD or USB media and power off the workstation.
6. Restart the workstation.

The following table lists the various keyboard light combinations used by the Boot Block ROM (when a PS 2 keyboard is attached to the workstation) and explains the meaning and action associated with each combination.

Table 4-2 Keyboard light combinations used by Boot Block ROM

FailSafe Boot Block mode	Keyboard LED activity*	State/Message
Num Lock	On	SoftPaq media is not present, is bad, or the drive not ready
Caps Lock	On	Enter password
Num, Caps, Scroll Lock	Flash in sequence, one at a time—N,C, SL	Keyboard locked in network mode
Num, Caps, Scroll Lock	On	Boot Block ROM Flash successful. Reboot the system

*Diagnostic lights do not flash on USB keyboards.

Asset tracking and security

Asset tracking features incorporated into your workstation provide asset tracking data that can be managed using HP Systems Insight Manager (SIM), HP Client Manager Software, or other systems management applications. Seamless, automatic integration between asset tracking features and these products enables you to choose the management tool that is best suited to your environment and to leverage investments in existing tools.

HP also offers several solutions for controlling access to valuable components and information. HP ProtectTools Embedded Security, if installed, prevents unauthorized access to data, checks system integrity, and authenticates third-party users attempting system access. Security features such as ProtectTools and the Hood Sensor (Smart Cover Sensor) help prevent unauthorized access to your data and to the internal components of the workstation. By disabling parallel, serial, or USB ports, or by disabling removable-media boot capability, you can protect valuable data assets. Memory Change and Hood Sensor (Smart Cover Sensor) alerts can be automatically forwarded to system management applications to deliver proactive notification of tampering with a workstation's internal components.

 **NOTE:** ProtectTools, the Hood Sensor (Smart Cover Sensor), and the (Smart Cover Lock) are available as options on select systems.

Use the following utilities to manage security settings on the HP workstation:

- Locally, using the Computer Setup (F10) Utility
- Remotely, using the HP Client Manager Software or System Software Manager which enables the secure, consistent deployment and control of security settings from a simple command line utility

The following table and sections refer to the management of workstation security through the Computer Setup (F10) Utility

Table 4-3 Security features overview

Feature	Purpose	How it is established
Removable Media Boot Control	Prevents booting from the removable media drives	From the Computer Setup (F10) Utility menu
Serial, Parallel, USB, or Infrared Interface Control	Prevents transfer of data through the integrated serial, parallel, USB, or infrared interface	From the Computer Setup (F10) Utility menu
Power-On Password	Prevents use of the workstation until the password is entered (applies to both initial system startup and restarts)	From the Computer Setup (F10) Utility menu
Setup Password	Prevents reconfiguration of the workstation (use of the Setup utility) until the password is entered	From the Computer Setup (F10) Utility menu
Network Server Mode	Provides unique security features for workstations used as servers	From the Computer Setup (F10) Utility menu

NOTE: For more information about the Computer Setup (F10) Utility, see [Computer Setup \(F10\) Utility menu on page 27](#).

Password security

The power-on password prevents unauthorized use of the workstation by requiring entry of a password to access applications or data each time the workstation is powered on or restarted. The setup password specifically prevents unauthorized access to the Computer Setup (F10) Utility and can also be used as an override to the power-on password. When prompted for the power-on password, entering the setup password instead enables access to the workstation.

You can establish a network-wide setup password to enable the system administrator to log in to all network systems to perform maintenance without having to know the power-on password.

 **NOTE:** System Software Manager and HP Client Manager Software enable remote management of setup passwords and other BIOS settings in a networked environment. For more information, see <http://www.hp.com/go/easydeploy>.

Establishing a setup password using the Computer Setup (F10) Utility

Establishing a setup password through the Computer Setup (F10) Utility prevents reconfiguration of the workstation (through the use of the Computer Setup (F10) Utility) until the password is entered.

To establish a setup password using the Computer Setup (F10) menu:

1. Power on or restart the workstation.
2. As soon as the computer is powered on, press and hold the **F10** key until you enter the Computer Setup (F10) Utility. Press **Enter** to bypass the title screen, if necessary.

 **NOTE:** If you do not press the **F10** key at the appropriate time, you must restart the workstation, and then press and hold the **F10** key again to access the utility.

If you are using a PS 2 keyboard, you might see a keyboard error message—disregard it.

3. Select **Security>Setup Password**, and then follow the onscreen instructions.
4. Before exiting, select **File>Save Changes**, and then select **Exit**.

Establishing a power-on password using workstation setup

Establishing a power-on password through the Computer Setup (F10) Utility prevents access to the workstation when power is connected, unless the password is entered. When a power-on password is set, the Computer Setup (F10) Utility presents Password Options in the Security menu. The password options include Network Server Mode and Password Prompt on Warm Boot.

When Network Server Mode is disabled, the password must be entered each time the workstation is powered on when the key icon appears on the monitor. When Password Prompt on Warm Boot is enabled, the password must also be entered each time the workstation is rebooted. When Network Server Mode is enabled, the password prompt is not presented during POST, but any attached PS 2 keyboard remains locked until you enter the power-on password.

To enable Network Server Mode, a power-on password must be set. The option to set this password is available under **Advanced>Password Options**. This option enables the system to boot without requiring the power-on password, but the keyboard and mouse are locked until you enter the password. The keyboard LEDs rotate constantly when the system is in locked mode.

To establish a power-on password through the Computer (F10) menu:

1. Power on or restart the workstation.
2. As soon as your workstation is powered on, press and hold the **F10** key until you enter the Computer Setup (F10) Utility. Press **Enter** to bypass the title screen, if necessary.
 **NOTE:** If you do not press the **F10** key at the appropriate time, you must restart the workstation, and then press and hold the **F10** key again to access the utility.
If you are using a PS 2 keyboard, you might see a keyboard error message—disregard it.
3. Select **Security>Power-On Password**, and then follow the onscreen instructions.
4. Before exiting, select **File>Save Changes**, and then **Exit**.

Entering a power-on password

1. Restart the workstation.
2. When the key icon appears on the monitor, enter the current password, and then press **Enter**.

 **NOTE:** Type carefully. For security reasons, the characters you enter do not appear on the screen.

If you enter the password incorrectly, a broken key icon appears. Try again. After three unsuccessful tries, you must restart the workstation before you can continue.

Entering a Setup Password

If a setup password has been established on the workstation, you will be prompted to enter it each time you run the Computer Setup (F10) Utility.

To enter a setup password:

1. Restart the workstation.
2. As soon as the workstation is powered on, press and hold the **F10** key until you enter the Computer Setup (F10) Utility. Press **Enter** to bypass the title screen, if necessary.

 **NOTE:** If you do not press the **F10** key at the appropriate time, you must restart the workstation and press and hold the **F10** key again to access the utility.

If you are using a PS 2 keyboard, you might see a keyboard error message—disregard it.

3. When the key icon appears on the monitor, enter the setup password, and press **Enter**.

 **NOTE:** Type carefully. For security reasons, the characters you enter do not appear on the screen.

If you enter the password incorrectly, a broken key icon appears. Try again. After three unsuccessful tries, you must restart the workstation before you can continue.

Changing a power-on or setup password

1. Restart the workstation.
2. To change the power-on password, go to step 4.
3. To change the setup password, as soon as the workstation is powered on, press and hold the **F10** key until you enter the Computer Setup (F10) Utility. Press **Enter** to bypass the title screen, if necessary.

 **NOTE:** If you do not press **F10** at the appropriate time, you must restart the workstation, and then press and hold the **F10** key again to access the utility.

If you are using a PS 2 keyboard, you might see a keyboard error message—disregard it.

4. When the key icon appears, enter the current password, a slash (/) or alternative delimiter character, your new password, another slash (/) or alternative delimiter character, and your new password again as shown:

current password/new password/new password

See [National keyboard delimiter characters on page 45](#) for information about the alternative delimiter characters.

 **NOTE:** Type carefully. For security reasons, the characters you enter do not appear on the screen.

5. Press **Enter**.

The new password takes effect the next time you power on the workstation.

The power-on and setup passwords can also be changed using the Security options in the Computer Setup (F10) Utility.

Deleting a power-on or setup password

1. Power on or restart the workstation.
2. To delete the power-on password, go to step 4.
3. To delete the setup password, as soon as the workstation is powered on, press and hold the **F10** key until you enter the Computer Setup (F10) Utility. (Press **Enter** to bypass the title screen, if necessary.)

 **NOTE:** If you do not press the **F10** key at the appropriate time, you must restart the computer and then press and hold the **F10** key again to access the utility.

Use the appropriate operating system shutdown process.

4. When the key icon appears, enter your current password followed by a slash (/) or alternative delimiter character: *current password/*.

 **NOTE:** See [National keyboard delimiter characters on page 45](#) for information about the alternative delimiter characters.

5. Press **Enter**.

National keyboard delimiter characters

Each keyboard is designed to meet country-specific requirements. The syntax and keys that you use for changing or deleting passwords depend on the keyboard included with your workstation.

Table 4-4 National keyboard delimiter characters

Language	Delimiter	Language	Delimiter	Language	Delimiter
Arabic	/	Greek	-	Russian	/
Belgian	=	Hebrew	.	Slovakian	-
BHCSY*	-	Hungarian	-	Spanish	-
Brazilian	/	Italian	-	Swedish/Finnish	/
Chinese	/	Japanese	/	Swiss	-
Czech	-	Korean	/	Taiwanese	/
Danish	-	Latin American	-	Thai	/
French	!	Norwegian	-	Turkish	.
French Canadian	é	Polish	-	U.K. English	/
German	-	Portuguese	-	U.S. English	/

NOTE: * Bosnia-Herzegovina, Croatia, Slovenia, and Yugoslavia

Clearing passwords

If you forget your password, you cannot access the workstation. See [Resetting the password jumper on page 155](#) for instructions about clearing passwords.

DriveLock

 **WARNING!** Enabling DriveLock can render a hard drive permanently inaccessible if the master password is lost or forgotten. No method exists to recover the password or access the data.

DriveLock uses an industry-standard security feature that prevents unauthorized access to the data on an ATA hard drive. DriveLock has been implemented as an extension to Computer Setup (F10) functions. It is only available when hard drives that support the ATA security command set are detected. On HP workstations, it is not available when the SATA emulation mode is RAID+AHCI or RAID.

DriveLock is intended for HP customers for whom data security is a paramount concern. For such customers, the cost of a hard drive and the loss of the data stored on it is inconsequential when compared to the damage that could result from unauthorized access to its contents.

In order to balance this level of security with the practical need to address the issue of a forgotten password, the HP implementation of DriveLock employs a two-password security scheme. One password is intended to be set and used by a system administrator, while the other is typically set and used by the end-user. There is no "back door" that can be used to unlock the drive if both passwords are lost. Therefore, DriveLock is most safely used when the data contained on the hard drive is replicated on a corporate information system or is regularly backed up. In the event that both DriveLock passwords are lost, the hard drive is rendered unusable. For users who do not fit the previously defined customer profile, this may be an unacceptable risk. For users who do fit this profile, it may be a tolerable risk, given the nature of the data stored on the hard drive.

DriveLock applications

The most practical use of the DriveLock security feature is in a corporate environment. The system administrator would be responsible for configuring the hard drive, which involves setting the DriveLock master password and a temporary user password. In the event that the user forgets the user password or the equipment is passed on to another employee, the master password can always be used to reset the user password and regain access to the hard drive.

HP recommends that corporate system administrators who choose to enable DriveLock also establish a corporate policy for setting and maintaining master passwords. This should be done to prevent a situation where an employee intentionally or unintentionally sets both DriveLock passwords before leaving the company. In such a scenario, the hard drive is rendered unusable and requires replacement. Likewise, by not setting a master password, system administrators might find themselves locked out of a hard drive and unable to perform routine checks for unauthorized software, other asset control functions, and support.

For users with less stringent security requirements, HP does not recommend enabling DriveLock. Users in this category include personal users, or users who do not maintain sensitive data on their hard drives as a common practice. For these users, the potential loss of a hard drive resulting from forgetting both passwords is much greater than the value of the data DriveLock has been designed to protect.

Access to Computer Setup (F10) and DriveLock can be restricted through the setup password. By specifying a setup password and not giving it to end users, system administrators are able to restrict users from enabling DriveLock.

Using DriveLock

When one or more hard drives that support the ATA security command set are detected, the DriveLock option appears under the Security menu in Computer Setup (F10). You are presented with options to set the master password and to enable DriveLock. A user password must be provided to enable DriveLock. Since the initial configuration of DriveLock is typically performed by a system administrator, a master password should be set first. HP encourages system administrators to set a master password whether they plan to enable DriveLock or not. This gives the administrator the ability to modify DriveLock settings if the drive is locked in the future. Once the master password is set, the system administrator might enable DriveLock or choose to leave it disabled.

If a locked hard drive is present, POST requires a password to unlock the device. If a power-on password is set and it matches the device's user password, POST does not prompt the user to re-enter the password. Otherwise, the user is prompted to enter a DriveLock password. For a cold-boot, use the

master or user password. For a warm-boot, you must enter the same password used to unlock the drive during the preceding cold-boot. Users are given two attempts to enter a correct password. During cold-boot, if neither attempt succeeds, POST continues but the drive remains inaccessible. During a warm-boot or restart from Windows, if neither attempt succeeds, POST halts and the user is instructed to cycle power.

To enable and set the DriveLock user password:

1. Power on or restart the workstation.
2. As soon as the workstation is powered on, press and hold the **F10** key until you enter the Computer Setup (F10) Utility. Press **Enter** to bypass the title screen, if necessary.

 **NOTE:** If you do not press the **F10** key at the appropriate time, you must restart the workstation, and then press and hold the **F10** key again to access the utility.

If you are using a PS2 keyboard, you might see a keyboard error message—disregard it.

3. Select **Security>DriveLock Security**.
4. For each DriveLock-capable drive, select a drive by pressing the **F10** key to accept.
5. Under Enable/Disable DriveLock options, select **Enable**, and then press the **F10** key to enable DriveLock for a particular drive.

 **CAUTION:** Forgetting the DriveLock password renders the drive unusable.

6. Enter a new user password, and then press the **F10** key to accept. This password may be 1 to 32 characters long.
7. Enter the password again in the Enter New Password Again field. If you forget this password, the drive is rendered permanently disabled.
8. Select **File>Save Changes and Exit**, and then press the **F10** key. After you press the **F10** key, the system performs a cold-boot before invoking the DriveLock function.

 **NOTE:** This process can also be used to set the DriveLock master password by selecting **Master** in Step 5.

When the workstation starts, you are prompted to enter the DriveLock password for each DriveLock-capable drive for which you have previously set a password. You are given two attempts to enter the password correctly. If the password is not entered correctly, the workstation attempts to boot anyway. However, the boot process most likely fails because data from a locked drive cannot be accessed.

In a single drive workstation, if the drive has DriveLock enabled, the workstation might not be able to boot to the operating system, and might try to boot from the network or from another storage device instead (depending on the boot ordering options). Regardless of the outcome of the boot attempts, the drive-locked drive remains inaccessible without the DriveLock password.

In a two-drive workstation that has a boot drive and a data drive, you can apply the DriveLock feature to the data drive only. In this case, the workstation can always boot, but the data drive is accessible only when the DriveLock password is entered.

Cold-boots require that you enter DriveLock passwords. However, DriveLock passwords are also required for warm-boots. For example, if you boot to DOS and enter **Ctrl-Alt-Del**, you must enter the DriveLock password before the workstation completes the next boot cycle. This warm-boot behavior is consistent with the DriveLock feature.

Hood Sensor (Smart Cover Sensor) (optional)

The optional Hood Sensor is a combination of hardware and software technology that can alert you when the workstation side access panel has been removed (if the sensor has been properly configured in the Computer Setup (F10) Utility). There are three levels of Hood Sensor protection:

Table 4-5 Hood Sensor protection levels

Level	Setting	Description
Level 0	Disabled	Hood Sensor is disabled (default).
Level 1	Notify User	When the workstation restarts, a message is displayed indicating that the workstation side access panel has been removed.
Level 2	Setup Password	When the workstation is restarted, a message is displayed indicating that the workstation side access panel has been removed. You must enter the setup password to continue.

Hood Sensor settings can be changed using the Computer Setup (F10) Utility.

Setting the Hood Sensor protection level

1. Power on or restart the workstation.
2. As soon as the workstation is powered on, press and hold the **F10** key until you enter the Computer Setup (F10) Utility. Press **Enter** to bypass the title screen, if necessary.

 **NOTE:** If you do not press the **F10** key at the appropriate time, you must restart the computer, and then press and hold the **F10** key again to access the Computer Setup (F10) Utility.

If you are using a PS 2 keyboard, you might see a keyboard error message—disregard it.

3. Select **Security>Smart Cover>Cover Removal Sensor**, and follow the onscreen instructions.
4. Before exiting, select **File>Save Changes**, and then select **Exit**.

Hood Lock (Smart Cover Lock) (optional)

The is an optional solenoid that secures the workstation access cover to the chassis. It is controlled by a BIOS password. When installed, the Hood Lock can prevent unauthorized access to the internal workstation components.

 **CAUTION:** For maximum cover lock security, be sure to establish a setup password. The setup password prevents unauthorized access to the Computer Setup utility.

Locking the Hood Lock

1. Power on or restart the workstation.
2. As soon as the workstation is powered on, press and hold the **F10** key until you enter the Computer Setup (F10) Utility. Press **Enter** to bypass the title screen, if necessary.

 **NOTE:** If you do not press the **F10** key at the appropriate time, you must restart the workstation and press and hold the **F10** key again to access the utility.

If you are using a PS2 keyboard, you might see a keyboard error message—disregard it.

3. Select **Security>Smart Cover>Cover Lock>Lock**.
4. Select **File>Save Changes and Exit**.

Unlocking the Hood Lock

1. Turn on or restart the workstation.
2. As soon as the workstation is powered on, press and hold the **F10** key until you enter the Computer Setup (F10) Utility. Press **Enter** to bypass the title screen, if necessary.

 **NOTE:** If you do not press the **F10** key at the appropriate time, you must restart the workstation and press and hold the **F10** key again to access the utility.

If you are using a PS2 keyboard, you might see a keyboard error message—disregard it.

3. Select **Security>Smart Cover>Cover Lock>Unlock**.
4. Select **File>Save Changes and Exit**.

Using the FailSafe key

If you enable the Hood Lock and cannot enter your password to disable it, you must have a FailSafe key to open the workstation side access panel. The FailSafe key is required in any of the following circumstances:

- Power outage
- Startup failure
- PC component failure (such as a processor or power supply)
- Forgotten password

 **CAUTION:** The side access panel FailSafe key is a specialized tool available from HP. Be sure to order the key from HP in advance so it is available when you need it.

To obtain the FailSafe Key, contact HP post sales support by telephone at: 1-800–hp-invent.

Cable lock (optional)

To prevent theft, the rear chassis panel of your workstation accommodates a keyed cable lock. This cable lock attaches to the chassis and secures it to the work area.

Security lock (Padlock loop) (optional)

The rear chassis panel of your workstation provides a padlock loop. A padlock can be attached in this loop to prevent workstation access panel removal.

Universal chassis clamp lock (optional)

The universal chassis clamp lock secures the access panel to the chassis using a screw-type attachment. A built in key lock prevents access to the securing screw. In addition, cables can be added to the universal chassis clamp lock to secure workstation peripherals, and to secure the workstation to the work area.

Fault notification and recovery

Fault notification and recovery features combine innovative hardware and software technology to prevent the loss of critical data and minimize unplanned downtime.

If the workstation is connected to a network that is managed by HP Client Manager Software, the computer sends a fault notice to the network management application. With HP Client Manager Software, you can also remotely schedule diagnostics to automatically run on all managed PCs and create a summary report of failed tests.

Drive Protection System

The Drive Protection System (DPS) is a diagnostic tool built into the hard drives that is installed in select HP workstations. The DPS is designed to help diagnose problems that might result in unwarranted hard drive replacement.

When HP workstations are built, each installed hard drive is tested using the DPS, and a permanent record of key information is written onto each drive. Every time the DPS is run, test results are written to the hard drive. The service provider can use this information to help diagnose conditions that required you to run the DPS software.

ECC fault prediction

When the workstation encounters an excessive number of error checking and correcting (ECC) memory errors, it displays a local alert message. This message contains detailed information about the errant memory module, enabling you to take action before you experience noncorrectable memory errors. ECC memory modules are standard on the HP xw4600 Workstation.

Thermal sensors

There are several thermal sensors in your HP xw4600 Workstation that regulate the workstation fans to maintain an acceptable, efficient chassis temperature.

Dual-state power button

With ACPI enabled, the power button can function either as an on/off switch or as a button. This feature does not completely turn off power, but instead causes the workstation to enter a low-power standby state. This allows you to power of the wowrkstation without closing applications, and to return to the same operational state without any data loss.

To change the power button configuration:

1. Select **Start**, and then select **Control Panel>Power Options**.
2. In Power Options Properties, select the **Advanced** tab.
3. In the Power Button section, select **Hibernate**. (Hibernate must be enabled in the Hibernate tab.)

After configuring the power button to function as a button, press the power button to put the system in a very low power state. Press the button again to bring the system out of this very low power state to full power state. To completely turn off all power to the system, press and hold the power button for four seconds.



△ **CAUTION:** Do not use the power button to power off the workstation unless the system is not responding; turning off the power without operating system interaction could cause damage to or loss of data on the hard drive.

5 Removal and replacement procedures

This chapter describes the removal and replacement procedures for most internal workstation components including the following topics:

Topics
Warnings and cautions on page 51
Service considerations on page 52
Customer Self-Repair on page 56
Predisassembly procedures on page 57
System board components on page 57
Removing and replacing components on page 58
Product recycling on page 106

Warnings and cautions

- ⚠ **WARNING!**  Any surface or area of the equipment marked with this symbol indicates the presence of a hot surface or hot component. If this surface is contacted, the potential for injury exists. To reduce the risk of injury from a hot component, enable the surface to cool before touching.
- ⚠ **WARNING!**  Any surface or area of the equipment marked with this symbol indicates the presence of an electrical shock hazard. To reduce the risk of injury from electrical shock, do not open any enclosed area marked with this symbol.
- ⚠ **WARNING!** To reduce the risk of electric shock or damage to your equipment:
 - Do not disable the power cord grounding plug. The grounding plug is an important safety feature.
 - Plug the power cord in a grounded (earthed) outlet that is easily accessible at all times.
 - Disconnect power from the equipment by unplugging the power cord from the electrical outlet.
- ⚠ **WARNING!** To reduce the risk of serious injury, read the *Safety & Comfort Guide*. It describes proper workstation setup, posture, health, and work habits for computer users, and provides important electrical and mechanical safety information. This guide is located at <http://www.hp.com/ergo>.
- ⚠ **WARNING!** If a product is shipped in packaging marked with this symbol, , the product must always be lifted by two persons to avoid personal injury due to product weight.
- ⚠ **CAUTION:** Static electricity can damage the electronic components of the workstation. Before beginning these procedures, be sure you discharge static electricity by briefly touching a grounded metal object.

-
- △ **CAUTION:** Observe the following cautions when removing or replacing a processor:
- Installing a processor incorrectly can damage the system board. Contact an HP authorized reseller or service provider to install the processor. If you plan to install the processor yourself, read all of the instructions carefully before you begin.
 - Failure to follow the workstation preparation instructions can result in an improperly installed processor, causing extensive workstation damage.
 - Processor socket pins are delicate and bend easily. Use extreme care when placing the processor in the socket.
-
- △ **CAUTION:** To prevent damage to the workstation, observe the following Electrostatic Discharge (ESD) precautions while performing the system parts removal and replacement procedures:
- Work on a static-free mat.
 - Wear a static strap to ensure that any accumulated electrostatic charge is discharged from your body to the ground.
 - Create a common ground for the equipment you are working on by connecting the static-free mat, static strap, and peripheral units to that piece of equipment.
-
-  **NOTE:** HP accessories are for use in HP Workstation products. They have been extensively tested for reliability and are manufactured to high quality standards.
-

Service considerations

The following sections describe service considerations that should be reviewed and practiced before removing and replacing any system components.

- △ **WARNING!** When lifting or moving the workstation, do not use the front bezel as a handle or lifting point. Lifting the workstation from the front bezel, or lifting it incorrectly, can cause the workstation to fall, possibly harming you and damaging the workstation. To properly and safely lift the workstation, lift it from the bottom.
-

Cautions, warnings, and safety precautions

For your safety, review the cautions, warnings, and safety precautions before accessing the workstation components. Also, review the *Safety and Regulatory Guide* that came with your workstation for more information.

ESD information

A sudden discharge of static electricity from your finger or other conductor can destroy static-sensitive devices or microcircuitry. Often, the discharge is neither felt nor heard, but damage occurs nonetheless. An electronic device exposed to electrostatic discharge (ESD) might not appear to be affected at all and can function normally for a while, but it has been degraded in the internal layers, reducing its life expectancy.

Networks built into many integrated circuits provide some protection, but in many cases, the discharge contains enough power to alter device parameters or melt silicon junctions.

Generating static

The following table shows that different activities generate different amounts of static electricity. Static electricity increases as humidity decreases.

Table 5-1 Static electricity

Event	Relative humidity		
	55%	40%	10%
Walking across carpet	7,500V	15,000V	35,000V
Walking across vinyl floor	3,000V	5,000V	12,000V
Motions of bench worker	400V	800V	6,000V
Removing bubble pack from PCB	7,000V	20,000V	26,500V
Packing PCBs in foam-lined box	5,000V	11,000V	21,000V

CAUTION: 700 volts can degrade a product.

Preventing ESD equipment damage

Many electronic components are sensitive to ESD. Circuitry design and structure determine the degree of sensitivity. The following packaging and grounding precautions are necessary to prevent damage to electric components and accessories:

- Transport products in static-safe containers such as tubes, bags, or boxes, to avoid hand contact.
- Protect all electrostatic parts and assemblies with nonconductive or approved containers or packaging.
- Keep electrostatic-sensitive parts in their containers until they arrive at static-free stations.
- Place items on a grounded surface before removing them from their containers.
- When handling or touching a sensitive component or assembly, ground yourself by touching the chassis.
- Avoid contact with pins, leads, or circuitry.
- Place reusable electrostatic-sensitive parts from assemblies in protective packaging or nonconductive foam.

Personal grounding methods and equipment

Use the following items to help prevent ESD damage to equipment:

- **Wrist straps**—flexible straps with a maximum of one megohm \pm 10% resistance in the ground cords. To provide a proper ground, wear the strap against bare skin. The ground cord must be connected and fit snugly into the banana plug connector on the grounding mat or workstation.
- **Heel straps, toe straps, and boot straps**—can be used at standing workstations and are compatible with most types of shoes or boots. On conductive floors or dissipative floor mats, use them on both feet with a maximum of one megohm \pm 10% resistance between the operator and ground.

Table 5-2 Static shielding protection levels

Method	Voltage
Antistatic plastic	1,500V
Carbon-loaded plastic	7,500V
Metallized laminate	15,000V

Grounding the work area

To prevent static damage in your work area:

- Cover the work surface with approved static-dissipative material. Use a wrist strap connected to the work surface, and properly grounded tools and equipment.
- Use static-dissipative mats, foot straps, or air ionizers to give added protection.
- Handle electrostatic-sensitive components, parts, and assemblies by the case or PCB laminate. Handle them only in static-free work areas.
- Disconnect power and input signals before inserting and removing connectors or test equipment.
- Use fixtures made of static-safe materials when fixtures must directly contact dissipative surfaces.
- Keep work area free of nonconductive materials, such as ordinary plastic assembly aids and Styrofoam.
- Use field service tools that are conductive, such as cutters, screwdrivers, and vacuums.

Recommended ESD prevention materials and equipment

Materials and equipment that are recommended for use in preventing static electricity include:

- Antistatic tape
- Antistatic smocks, aprons, and sleeve protectors
- Conductive bins and other assembly or soldering aids
- Conductive foam
- Conductive tabletop workstations with a ground cord of one megohm \pm 10% resistance
- Static-dissipative table or floor mats with a hard-tie to ground
- Field service kits
- Static awareness labels
- Wrist straps and footwear straps providing one megohm \pm 10% resistance
- Material-handling packages
- Conductive plastic bags
- Conductive plastic tubes
- Conductive tote boxes
- Opaque shielding bags
- Transparent metallized shielding bags
- Transparent shielding tubes

Tools and software requirements

- Torx T-15 driver
- Flat blade and cross-tip screwdrivers
- Diagnostics software

Screws

The screws used in the workstation are not interchangeable. Metric screws are used for optical and diskette devices, and American National Standards Institute (ANSI) screws are used for hard drives. If an incorrect screw is used during the reassembly process, it can damage the workstation. HP strongly recommends that you keep all screws removed during disassembly with the removed part, and then returned to their proper locations.

NOTE: Metric screws have a black finish. ANSI (unified) screws have a silver finish.

As each subassembly is removed from the workstation, place the subassembly away from the work area to prevent damage.

Additional drive-guide screws are provided on the system chassis in case they are needed. The [Figure 5-1 Metric and ANSI screw identification on page 55](#) shows the eight metric M3 screws (1) located on the chassis near the 5.25-inch optical drive bays. These screws can be used to mount additional optical drives or an optional diskette drive. There are four ANSI 6–32 screws (2) located on the chassis near the hard drive. These screws can be used to mount additional hard drives in the 3.5 inch hard drive cage.

NOTE: The metric (black) and ANSI (silver) screws are not interchangeable.

Figure 5-1 Metric and ANSI screw identification

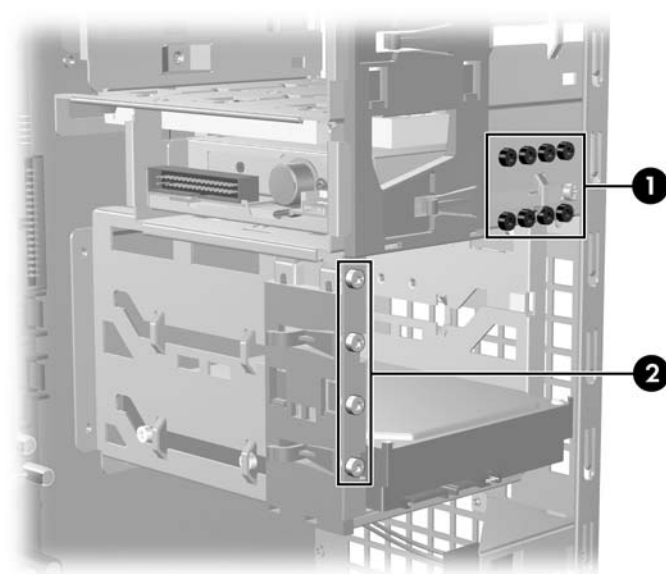

Table 5-3 Screw ID

Item	Description
1	Metric screws (M3)
2	ANSI screws (6–32)

Special handling of components

The components included in this section require special handling when servicing the workstation.

- ⚠ **WARNING!** Do not use the front bezel as a handle or lifting point when lifting or moving the workstation. Lifting the workstation from the front bezel, or lifting it incorrectly, could cause the workstation to fall, causing possible injury to you, and damage to the workstation. To properly and safely lift the workstation, lift from the bottom of the workstation for either the desktop or minitower configuration.

Cables and connectors

Cables must be handled with care to avoid damage. Apply only the tension required to seat or unseat cables during insertion or removal from the connector. Handle cables by the connector or pull-strap whenever possible. In all cases, avoid bending or twisting the cables, and be sure that the cables are routed in such a way that they cannot be caught or snagged by parts being removed or replaced.

- ⚠ **CAUTION:** When servicing this workstation, be sure that cables are placed in their proper location during the reassembly process. Improper cable placement can damage the workstation.

Hard drives

Hard drives are fragile, precision components. Therefore, you must avoid subjecting them to physical shock and vibration. This guideline applies to failed drives and replacement drives and spares.

- Do not remove hard drives from the shipping package for storage. Keep hard drives in their protective packaging until they are actually mounted in the workstation.
- Avoid dropping hard drives from any height.
- If you are inserting or removing a hard drive, power off the workstation. Do not remove a hard drive while the workstation is powered on or in standby mode.
- Before handling a drive, be sure that you discharge static electricity. While handling a drive, avoid touching the connector. For more information about preventing electrostatic damage, see [ESD information on page 52](#).

- ⚠ **CAUTION:** To prevent possible ESD damage when the drive is installed, always connect the drive power cable before connecting the data cable. This discharges accumulated static electricity through the drive power cable to the workstation chassis.

- Do not use excessive force when inserting a drive.
- Avoid exposing a hard drive to liquids, temperature extremes, or products with magnetic fields such as monitors or speakers.

Lithium coin cell battery

The battery included with the workstation provides power to the real-time clock and has a minimum lifetime of about three years.

For instructions on battery removal and replacement, see [Battery on page 84](#).

- ⚠ **WARNING!** This workstation contains a lithium battery. There is a risk of fire and chemical burn if the battery is handled improperly. Do not disassemble, crush, puncture, short the external contacts, dispose of in water or fire, or expose the battery to temperatures higher than 60° Centigrade (140° Fahrenheit).

- 🗑 **NOTE:** Batteries, battery packs, and accumulators should not be disposed of with general household waste.

Customer Self-Repair

Customer Self-Repair enables you to obtain replacement parts and install them yourself on the workstation. For more information, see: <http://www.hp.com/go/selfrepair/>.

Predisassembly procedures

Perform the following steps before servicing the workstation:

1. Close all open software applications.
2. Remove all diskettes, CDs, and DVDs from the workstation.
3. Shut down the operating system.
4. Power off the workstation and all peripheral devices connected to it.
5. Remove or disengage all security devices that prevent you from opening the workstation.
6. Disconnect the power cord from the electrical outlet and then from the workstation.
7. Disconnect all peripheral device cables from the workstation.

System board components

The following figure shows the system board connectors and sockets on the HP xw4600 Workstation.

Figure 5-2 System board component identification

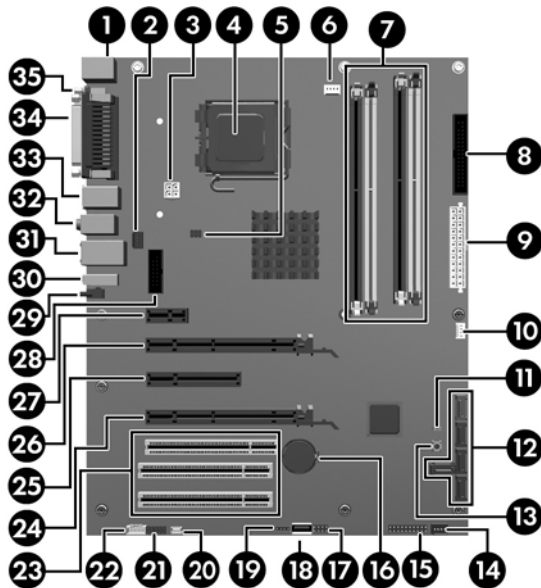

Table 5-4 System board components

No.	Component	No.	Component	No.	Component
1	Keyboard/mouse	13	Clear CMOS button	25	PCI Express x8 (4)*
2	Rear chassis fan	14	Front chassis fan	26	PCI Express x16
3	Processor power	15	Front control panel	27	PCI Express x1
4	Processor	16	Battery	28	2nd serial adapter port
5	Solenoid hood lock	17	Front USB	29	eSATA
6	Processor fan	18	USB	30	USB
7	Memory module sockets	19	Internal USB	31	Network/USB
8	Diskette drive	20	Speaker	32	Audio

Table 5-4 System board components (continued)

No.	Component	No.	Component	No.	Component
9	Main power	21	Front audio	33	USB
10	Chassis intrusion switch	22	Auxiliary audio	34	Parallel
11	Password jumper	23	PCI 32/33	35	Serial
12	SATA	24	PCI Express x16		

* Electrically x4 bandwidth

Removing and replacing components

This section provides procedures to remove and install hardware components on your workstation. Before servicing your workstation, review the safety information and precautions in the [Service considerations on page 52](#), and the *Safety and Regulatory Information* for your workstation.

1. Read all safety information and precautions.
2. Locate and clear a suitable work area.
3. Power down the workstation and disconnect power from the workstation.
4. Gather your tools.
5. Service the workstation.
6. Restore power to the workstation.

Disassembly order

Use the following table to determine the sequence in which to remove major workstation components.

Table 5-5 Workstation component disassembly order

Predisassembly (Predisassembly procedures on page 57)
Security lock (Security lock (Padlock loop) (optional) on page 59)
Side access panel (Side access panel on page 61)
Hood Sensor (Hood Sensor (Smart Cover Sensor) (optional) on page 63)
Smart Cover Lock solenoid (Smart Cover Lock solenoid (optional) on page 63)
Front bezel (Front bezel on page 64)
Bezel blanks (Bezel blanks on page 65)
Front panel I/O device assembly (Front panel I/O device assembly on page 66)
Power button assembly (Power button assembly on page 68)
Optical drives (Optical drive (minitower configuration) on page 87 , Optical drive (desktop configuration) on page 90)
Diskette drive (Diskette drive (optional) on page 92)
System speaker (System speaker on page 69)
Power supply (Power supply on page 70)
System fan (System fan assembly on page 71)
PCI card guide and front fan (optional) (Front PCI card guide and fan removal (optional) on page 83)
Memory (Memory on page 72)
PCI retainer (PCI card support bracket on page 76)
PCI slots (PCI card slots on page 76)
PCI Express card (PCI Express cards on page 78)
PCI card (PCI card on page 80)
Hard drives (SAS hard drive on page 93), SATA hard drive on page 97)
Processor heatsink (Processor heatsink on page 101)
Processor (System processor on page 103)
System board (System board on page 105)
Battery (Battery on page 84)

Security lock (Padlock loop) (optional)

If a security padlock is installed on your workstation, remove it before servicing the workstation.

Removing the security lock

To remove the padlock, unlock it and slide it out of the padlock loop as shown in the following figure.

Figure 5-3 Removing the security lock



Cable lock (optional)

If a cable lock is installed on your workstation, remove it before servicing the workstation.

Removing the cable lock

To remove the cable lock, unlock it and pull it out of the cable lock slot as shown in the following figure.

Figure 5-4 Removing the cable lock



Universal chassis clamp lock (optional)

If a universal chassis clamp lock is installed on your workstation, remove it before servicing the workstation.

Removing the chassis clamp lock

To remove the lock:

1. Unlock the device and remove the locking mechanism.

Figure 5-5 Unlocking the device



2. Remove the screw attaching the lock to the chassis.

Figure 5-6 Removing the lock screws



Side access panel

Before accessing the internal components of the workstation, the side access panel must be removed.

This section describes how to remove and replace the side access panel.

Removing the side access panel

To remove the side access panel:

⚠ **WARNING!** Before removing the workstation side access panel, be sure that the workstation is powered off and that the power cord is disconnected from the electrical outlet.

1. Disconnect power from the system ([Predisassembly procedures on page 57](#)).
2. Unlock any locks that may be present (cable lock or padlock).
3. Pull open the access panel handle (1).

Figure 5-7 Removing the access panel

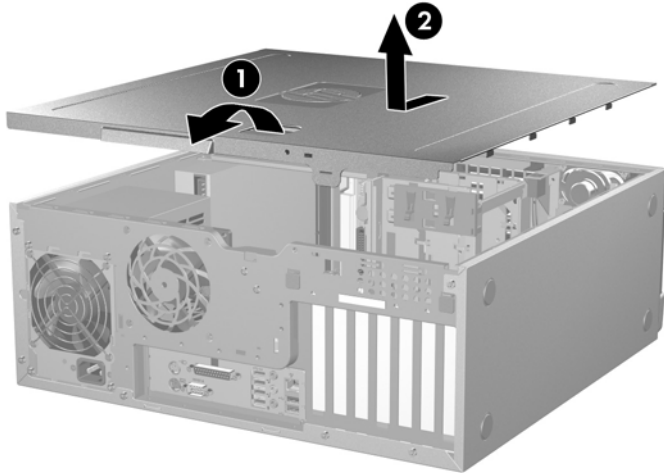

4. Slide the access panel toward the rear of the workstation and lift off the cover (2).

Replacing the side access panel

To replace the side access panel:

1. Place the access panel over the chassis and align the tabs along the edges of the access panel with the slots in the chassis.
2. Press the access panel down, fitting the tabs into the slots.
3. Slide the access panel toward the front of the chassis until it locks into place.

Figure 5-8 Installing the access panel

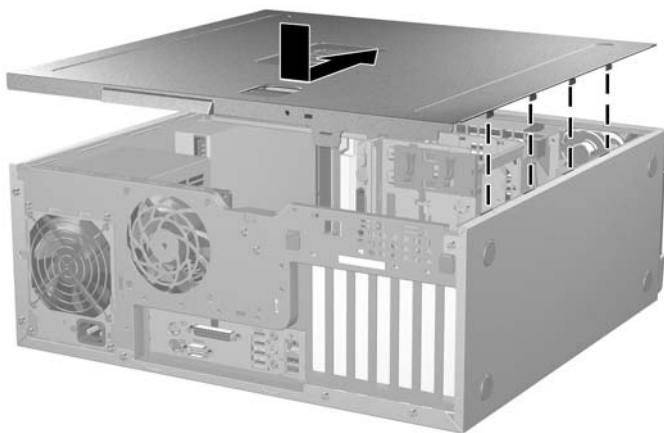

Hood Sensor (Smart Cover Sensor) (optional)

This section describes how to remove the Hood Sensor.

Removing the Hood Sensor

To remove the Hood Sensor:

1. Disconnect power from the system ([Predisassembly procedures on page 57](#)) and remove the side access panel ([Removing the side access panel on page 61](#)).
2. Disconnect the Hood Sensor connector from system board (1).

Figure 5-9 Removing the Hood Sensor

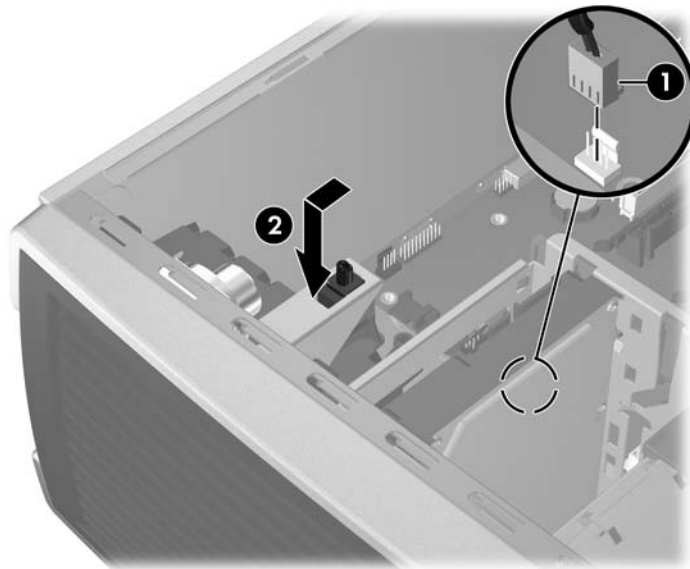

3. Slide the Hood Sensor forward, push it down, and then remove it from the chassis (2).

 **NOTE:** To replace the Hood Sensor, reverse the previous steps.

Smart Cover Lock solenoid (optional)

This section describes how to remove the Smart Cover Lock solenoid

Removing the Smart Cover Lock solenoid

To remove the Smart Cover Lock solenoid:

 **NOTE:** To purchase a FailSafe key, contact your authorized HP reseller or service provider, or see the HP Web site for ordering information.

1. Disconnect power from the system ([Predisassembly procedures on page 57](#)) and remove the side access panel ([Removing the side access panel on page 61](#)).

2. Disconnect the solenoid cable from the system board (1).

Figure 5-10 Removing the Smart Cover Lock solenoid assembly

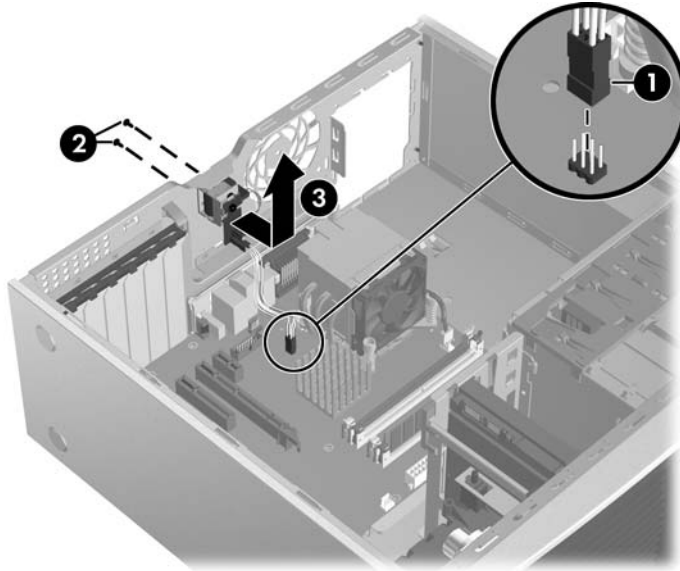

3. Using the FailSafe key (T-15 wrench), unscrew the two screws from the back of the chassis (2).
4. Slide the solenoid assembly away from the chassis and out of the workstation (3).

 **NOTE:** To install the Smart Cover Lock solenoid assembly, reverse the previous steps.

Front bezel

This section describes how to remove and replace the front bezel.

Removing the front bezel

To remove the front bezel:

1. Lift the two release snaps located on the front bezel (1).

Figure 5-11 Removing the front bezel

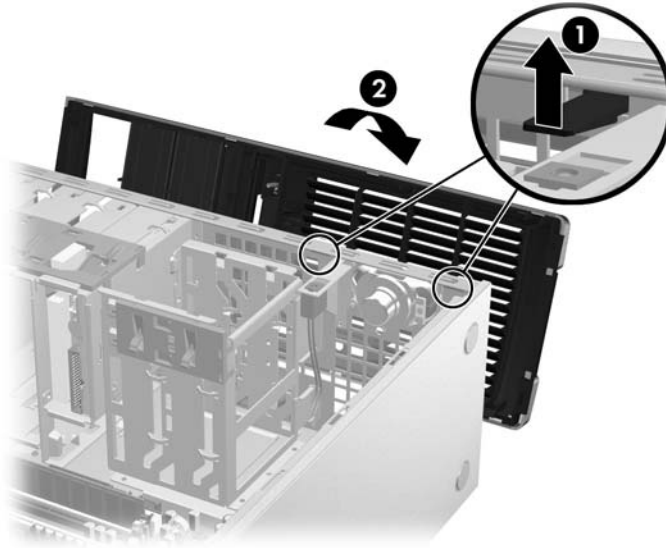

2. Rotate the front bezel away from the chassis to remove the bezel (2).

Replacing the front bezel

To replace the front bezel, align front bezel on the bottom and rotate in until it snaps into place.

Bezel blanks

This section describes how to remove bezel blanks

Removing bezel blanks

To remove bezel blanks:

1. Disconnect power from the system ([Predisassembly procedures on page 57](#)) and remove the front bezel ([Removing the front bezel on page 65](#)).

2. Gently push the subpanel out the back of the front bezel (1).

Figure 5-12 Removing the bezel blanks

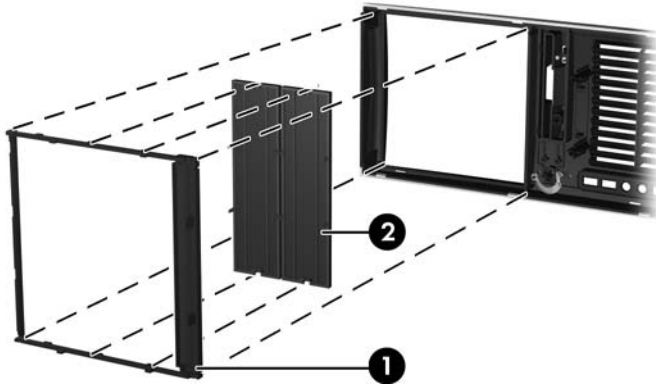

3. Remove the desired bezel blank by applying outward pressure on the subpanel (1) and pulling the blank away (2).

 **NOTE:** The bezel blanks are keyed to assist you in replacing them. Also, the subpanel can be rotated 90 degrees to install optical drives in a desktop orientation.

Front panel I/O device assembly

This section describes how to remove and install a front panel I/O device assembly.

Removing the front panel I/O device assembly

To remove the front panel I/O device assembly:

1. Disconnect power from the system ([Predisassembly procedures on page 57](#)), remove the side access panel ([Removing the side access panel on page 61](#)), and then remove the front bezel ([Removing the front bezel on page 65](#)).
2. If necessary, unlatch the plastic snap that secures the cables inside the chassis (1), and then disconnect the front panel I/O device assembly cables from the system board (2).

Figure 5-13 Removing front panel I/O device cables

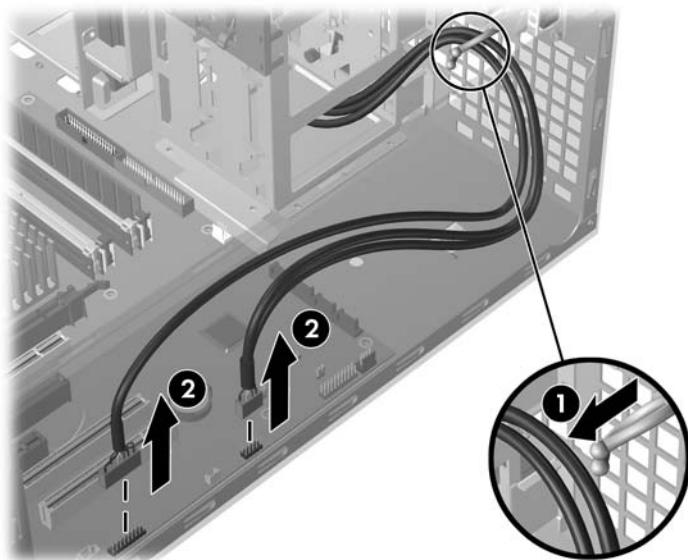

3. Remove the two smaller Torx screws (1) that hold the front panel I/O device assembly and bracket to the chassis (3).

Figure 5-14 Removing the front panel I/O device assembly

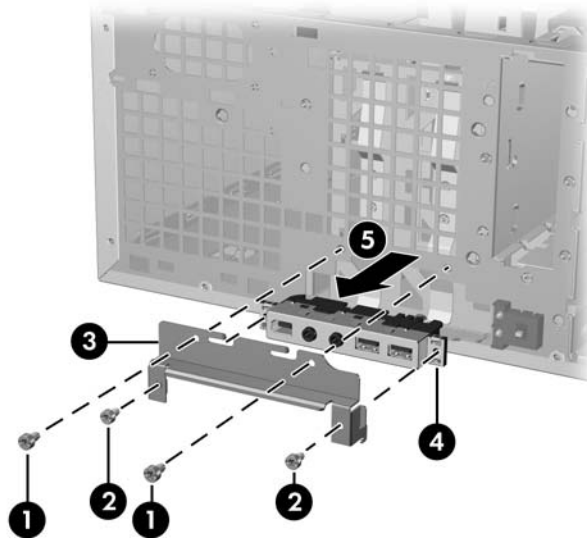

4. Remove the two larger Torx screws (2) that hold the front panel I/O device assembly to the bracket (3).
5. Separate the bracket from the front panel I/O device assembly.
6. Pull the front panel I/O device assembly out about two inches from the chassis (5).
7. Pull the front panel cables through the chassis and through the front of the workstation. You might have to slide the cables out one at a time.

Installing the front panel I/O device assembly

To install the front panel I/O device assembly:

1. Thread each front panel I/O device assembly cable through the same holes from which they were removed.
2. Push the front panel I/O device assembly into the chassis. Using your fingers, orient the cables so that there is enough room for the front panel I/O device assembly to easily fit in its slot.
3. Loosely place the bracket on the front panel I/O device assembly and hook the bracket to the chassis.

4. Screw the bracket to the front panel I/O device assembly, and then screw the bracket to the chassis.
5. Connect the front audio cable to the audio connector (1). Connect the front USB cable to the USB connector (2). Connect the front control panel cable to the control panel connector (3). If an IEEE-1394 card is installed, connect the front IEEE-1394 cable to the card connector.

Figure 5-15 Attaching the front panel I/O device assembly cables

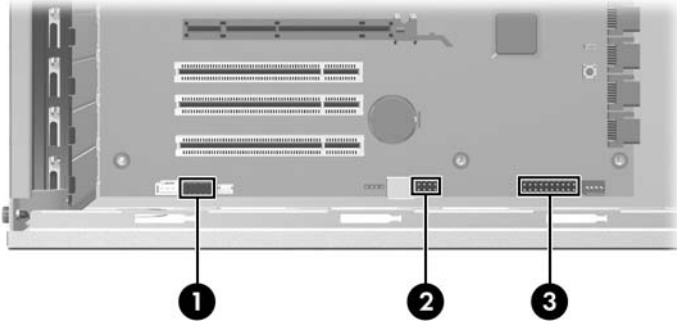

Power button assembly

This section describes how to remove the power button assembly.

Removing the power button assembly

To remove the power button assembly:

1. Disconnect power from the system ([Predisassembly procedures on page 57](#)), remove the side access panel ([Removing the side access panel on page 61](#)), remove the front bezel ([Removing the front bezel on page 65](#)), and then remove the front panel I/O device assembly ([Removing the front panel I/O device assembly on page 66](#)).
2. Disconnect the power button assembly cable from the system board.

Figure 5-16 Removing the power button assembly cable

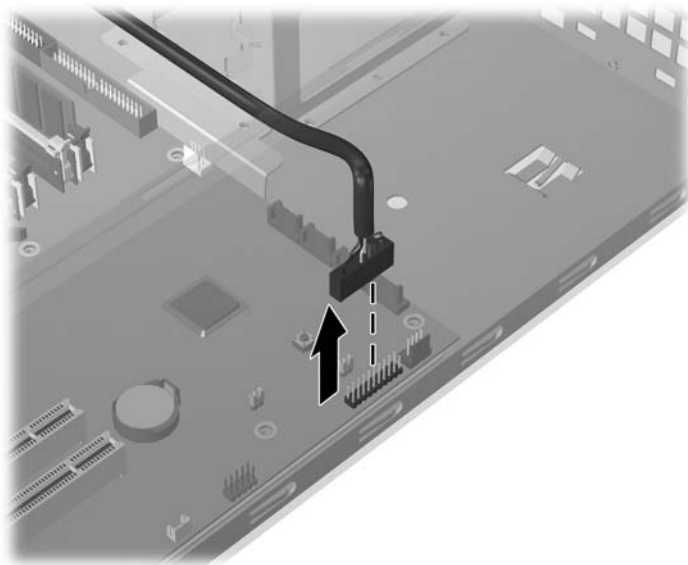

3. Press in on the clips that secure the power button assembly to the chassis (1).

Figure 5-17 Removing the power button assembly

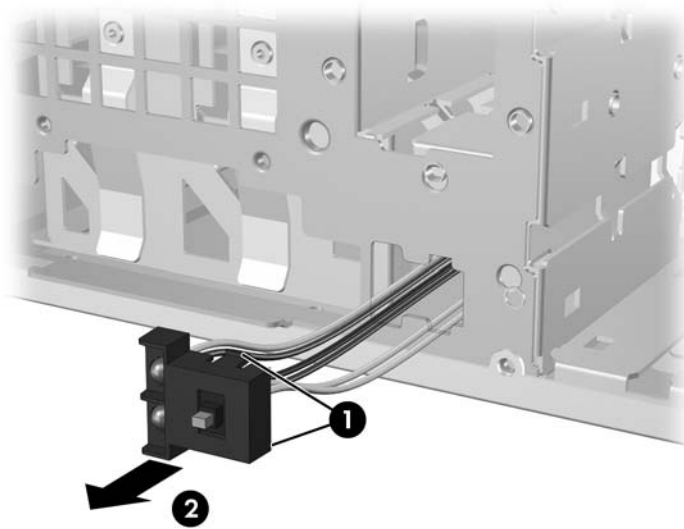

4. Dislodge the metal clip from the chassis by rocking the power button assembly back and forth, and then slide the power button assembly out from the front of the chassis (2).

 **NOTE:** To replace the power button assembly, reverse the previous steps.

System speaker

This section describes how to remove the system speaker.

Removing the system speaker

To remove the system speaker:

1. Disconnect power from the system ([Predisassembly procedures on page 57](#)) and remove the side access panel ([Removing the side access panel on page 61](#)).

2. Disconnect the speaker cable from the system board (1).

Figure 5-18 Removing a system speaker

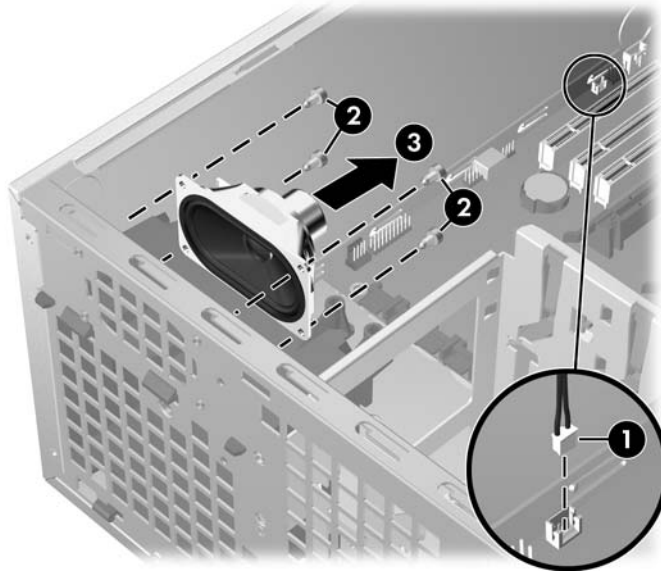

3. Remove the four screws (2) securing the speaker to the chassis and remove the speaker from the chassis (3).

 **NOTE:** To replace the speaker, reverse the previous steps.

Power supply

This section describes how to remove the power supply.

Removing the power supply

To remove the power supply:

1. Disconnect power from the system ([Predisassembly procedures on page 57](#)) and remove the side access panel ([Removing the side access panel on page 61](#)).

 **TIP:** The next step requires disconnecting several power cables. To ease the installation of the power supply, it is helpful to write down the numbers on the cables so you can easily reconnect the cables to the correct devices.

2. Disconnect all cables from the system board, drives, and cards.

3. Remove the four screws from the back panel (1).

Figure 5-19 Removing the power supply

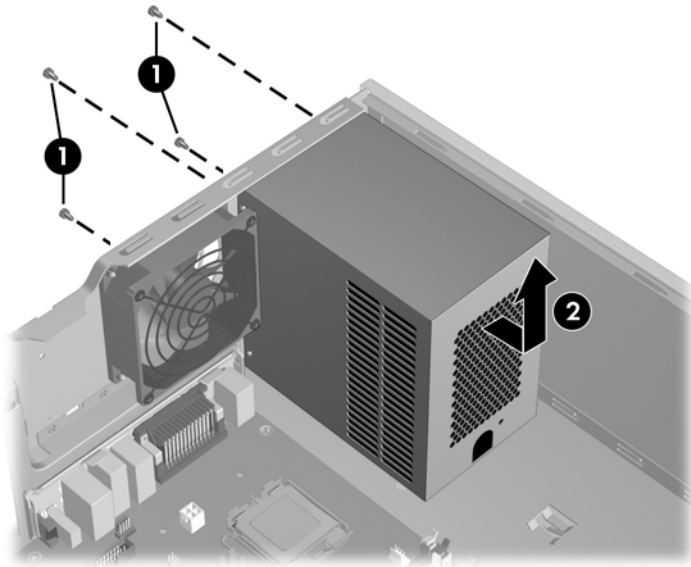

4. Slide the power supply toward the front of the chassis and lift it out of the chassis (2).

 **NOTE:** To replace the power supply, reverse the previous steps.

System fan assembly

This section describes how to remove the system fan assembly.

Removing the system fan assembly

To remove the system fan assembly:

1. Disconnect power from the system ([Predisassembly procedures on page 57](#)) and remove the side access panel ([Removing the side access panel on page 61](#)).

2. Disconnect the fan plug from the system board (1).

Figure 5-20 Removing the system fan

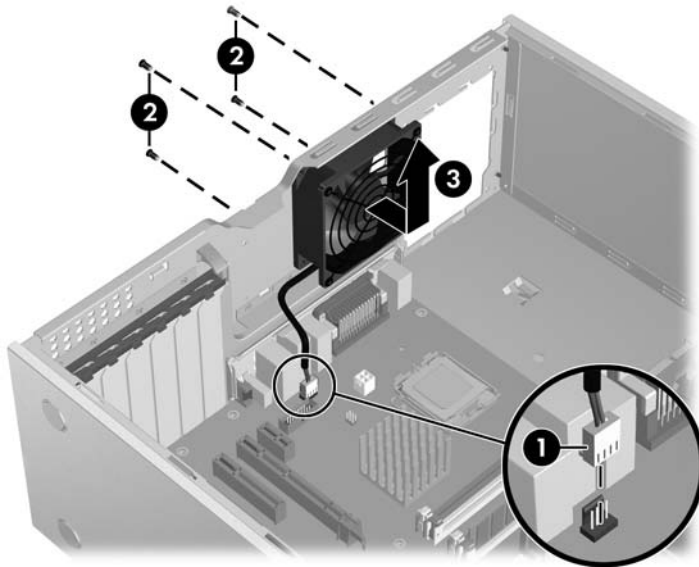

3. Use a cross-tip screwdriver to remove the four screws from the rear of the chassis (2).
4. Lift the system fan out of the chassis (3).

△ **CAUTION:** When replacing the system fan, be sure that the fan is seated with the airflow direction arrow pointing toward the rear of the chassis.

📝 **NOTE:** To install the system fan assembly, reverse these steps.

Memory

This section describes how to remove and install a memory module.

Removing a memory module

1. Disconnect power from the system ([Predisassembly procedures on page 57](#)) and remove the side access panel ([Removing the side access panel on page 61](#)).

△ **CAUTION:** To ensure that memory modules are not damaged during removal or installation, power off the workstation and unplug the power cord from the AC power outlet. If you do not unplug the power cord before installing memory, the modules might be damaged and the system will not recognize the memory changes.

2. Push gently outward on the socket levers (1).

Figure 5-21 Removing a memory module

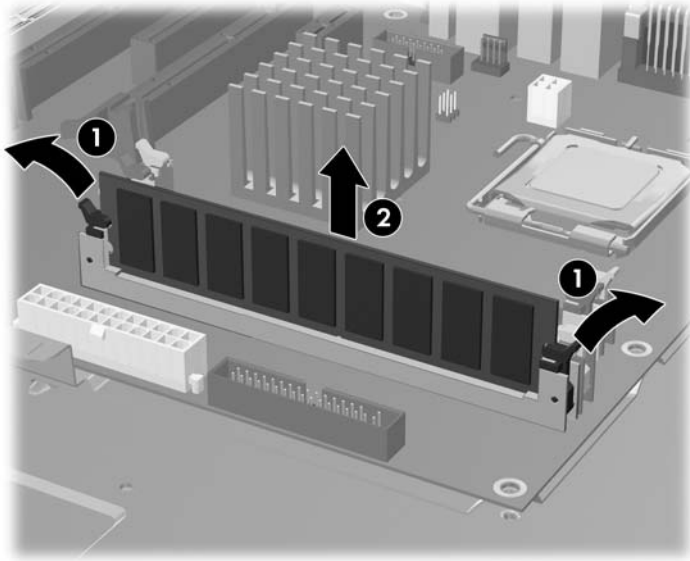

3. Lift the DIMM straight up and out of the socket. Store the DIMM in an anti static bag (2).

Installing a memory module

This section describes how to install a memory module.

Supported DIMM configurations

The HP xw4600 Workstation supports these memory module configurations:

- 512 MB to 8 GB RAM
- Four DIMM slots
- Dual-channel DIMMs

Memory module requirements

△ **CAUTION:** HP only ships DIMMs that are electrically and thermally compatible with this workstation. Because third-party DIMMs might not be electrically or thermally compatible, they are not supported by HP.

📄 **NOTE:** DIMMs and their sockets are keyed for proper installation. Be sure these guides line up when installing DIMMs.

Use only industry-standard, unbuffered, PC2-5300E (667 MHz) or PC2-6400E (800 MHz) DIMMs.

If multiple DIMMs are installed in a workstation, they must be installed in pairs of the same size and type in each channel.

Required DIMM installation order

Use the following illustration as a guide for installing memory:

- If installing only one DIMM, it must be installed in socket (1).
- The first DIMM pair must be installed in sockets (1) and (3).
- The second DIMM pair must be installed in sockets (2) and (4).

Figure 5-22 Required DIMM installation order

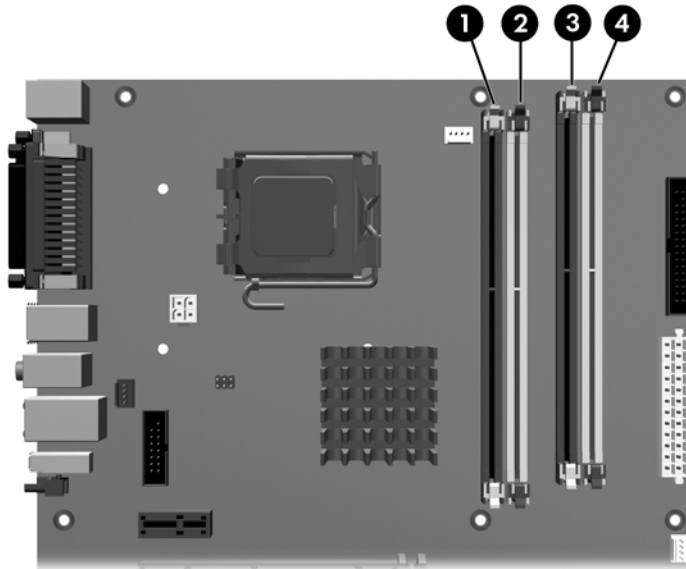

Installing a memory module

To install a memory module:

1. Disconnect power from the system ([Predisassembly procedures on page 57](#)), and then remove the side access panel ([Removing the side access panel on page 61](#)).

2. Push gently outward on the socket levers.

Figure 5-23 Opening the DIMM socket levers

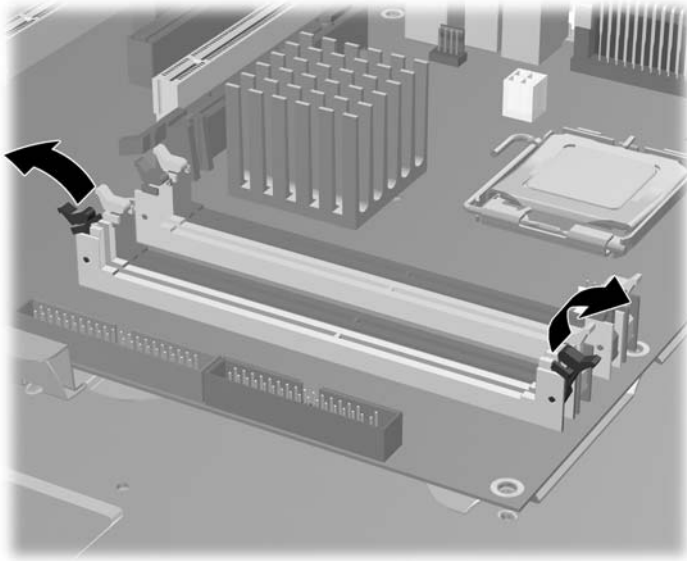

3. Align the DIMM connector key with the DIMM socket key, and then seat the DIMM firmly in the socket (1).
4. Secure the socket levers (2).

Figure 5-24 Installing a memory module

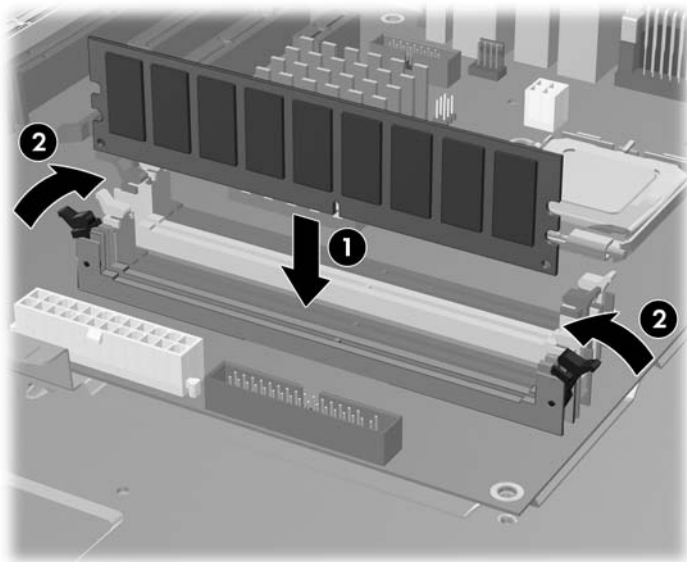

PCI card slots

The following figure illustrates the xw4600 Workstation PCI card slots.

Figure 5-25 Identifying PCI card slots

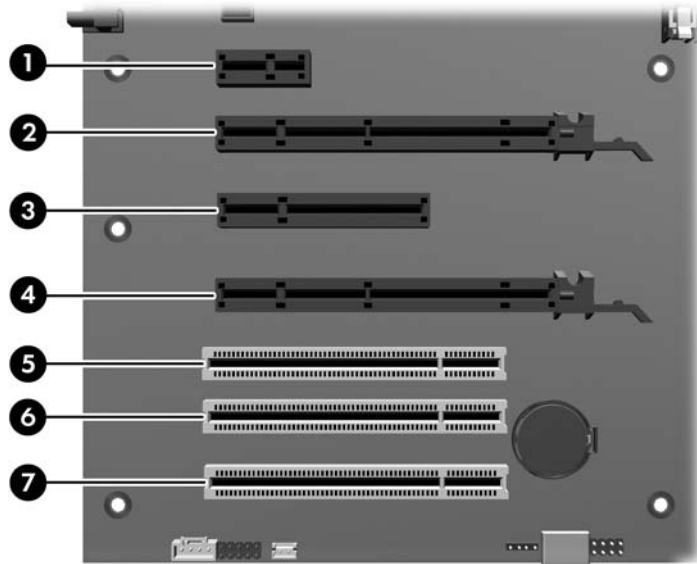

Table 5-6 PCI slots

Slot	Type	Slot power (Maximum)
1	PC-Express x1	25W
2	PCI-Express x16*	75W
3	PCI-Express x8 (x4)	25W
4	PCI-Express x16*	75W
5	PCI 32/33	25W
6	PCI 32/33	25W
7	PCI 32/33	25W

* The maximum graphics configuration can be: two 75W cards (one in slot two; one in slot four), or one 150W card, in either slot 2 or slot 4. If a 150W card is used, the adjacent slot must remain empty.

Graphics cards greater than 75W require the use of a graphics cable adapter.

NOTE: In addition to these slot power specifications, the overall power consumption of the system (including I/O cards, processor, and memory) must not exceed the maximum rating of the system power supply.

PCI card support bracket

Some PCI cards have retainers installed to prevent movement during shipping.

Removing a PCI card support bracket

To remove a PCI card support bracket:

1. Disconnect power from the system ([Predisassembly procedures on page 57](#)) and remove the side access panel ([Removing the side access panel on page 61](#))
2. Remove the two screws that attach the bracket to the chassis (1).

Figure 5-26 Removing a PCI card support bracket

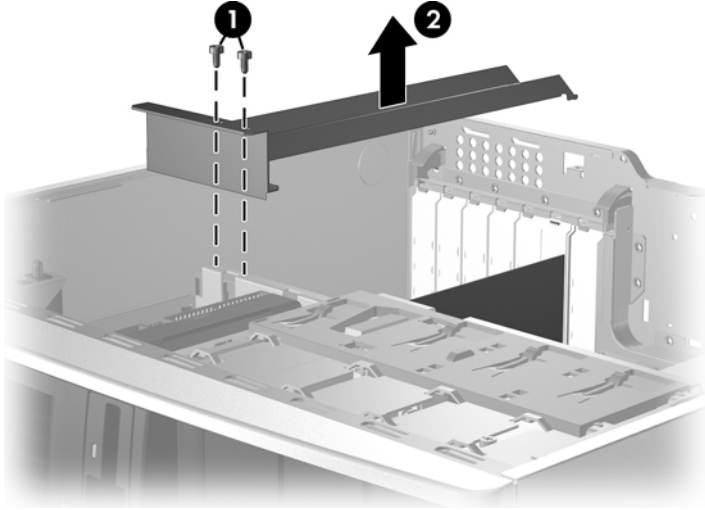

3. Lift the bracket out of the chassis (2).

Installing a PCI card support bracket

To install the PCI card support bracket:

1. Disconnect power from the system ([Predisassembly procedures on page 57](#)) and remove the side access panel ([Removing the side access panel on page 61](#)).

- Align the rear bracket with the holes in the rear of the chassis (1), and then rotate the bracket down into position (2).

Figure 5-27 Installing a PCI card support bracket

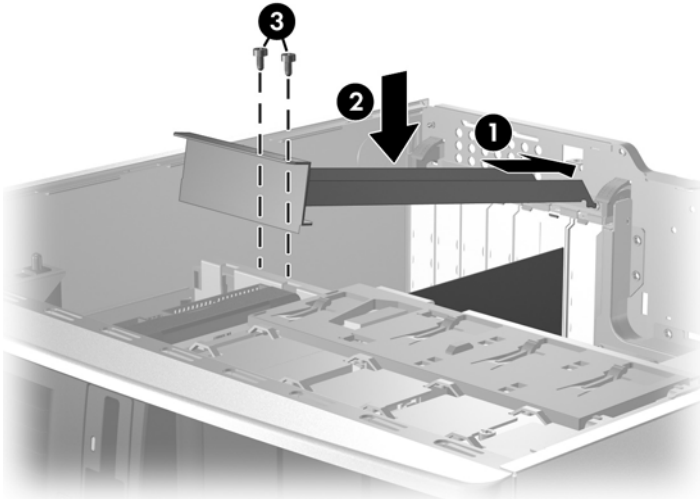

- Secure the bracket to the chassis with two screws (3).

PCI Express cards

PCI Express improves system attributes and enables a low-power, scalable, high-bandwidth communication path using a small number of connections, or wires, compared to traditional parallel interfaces such as PCI. The PCI Express I/O slots can support other PCI Express cards with less bus bandwidth than what is physically defined for the slot. Use the following table to determine PCI Express card compatibility.

Table 5-7 PCI Express compatibility matrix for the HP xw4600 Workstation

Slot type	Mechanical compatibility	Electrical compatibility
PCI Express x1 slot	x1 cards	x1 modes
PCI Express x8 (x4) slot	x1, x4, and x8	x1 and x4 modes
PCI Express x16 slot	x1, x4, x8 and x16 cards	x1, x4, x8, and x16 modes

Removing a PCI Express card

To remove a PCI Express card:

- Disconnect power from the system ([Predisassembly procedures on page 57](#)), remove the side access panel ([Removing the side access panel on page 61](#)), and then remove the PCI retainer, if installed ([PCI card support bracket on page 76](#)).

2. Open the PCI card retention clamp. Press the retention clamp levers down to unsnap, and then rotate them up (1).

Figure 5-28 Removing a PCI Express card

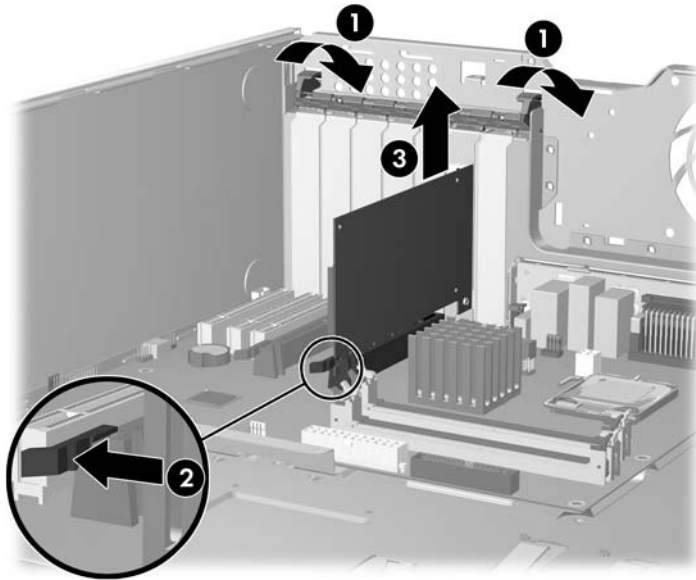

3. If removing a PCI Express x16 graphics card, press in on the release lever (2) while lifting the card (3) out of the chassis. Store the card in an anti-static bag.
If removing a PCI Express card without a release lever, simply lift the card out of the chassis.
4. Install a PCI slot cover and close the PCI retention clamp. If the PCI retention clamp levers do not close, ensure that all cards are properly seated, and then try again.

Installing a PCI Express card

To install a PCI Express card:

1. Disconnect power from the system ([Predisassembly procedures on page 57](#)), remove the side access panel ([Removing the side access panel on page 61](#)), and remove the PCI retainer ([PCI card support bracket on page 76](#)), if installed.

2. Open the PCI card retention clamp. Press the retention clamp levers down to unsnap, and then rotate them up (1).

Figure 5-29 Installing a PCI Express card

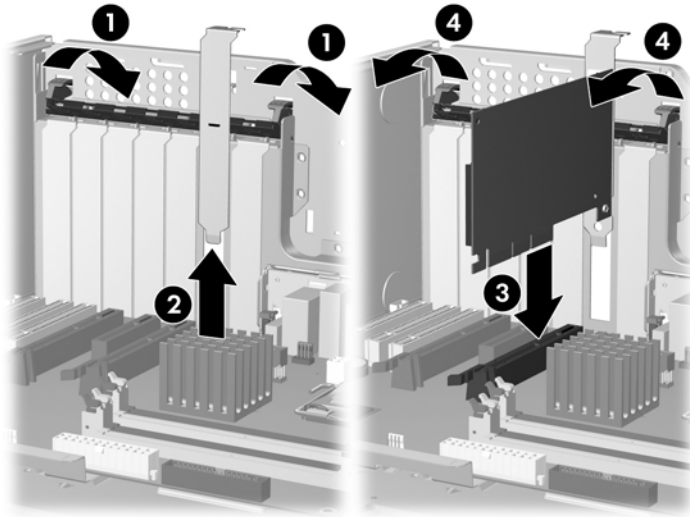

3. Remove the PCI slot cover (2).
4. Align the keyed components of the PCI card with the slot, and then firmly seat the card in the slot (3).
5. Close the PCI card retention clamp by rotating the clamp downward and pressing the two green clamp levers from the rear panel of the chassis (4).

PCI card

This section describes removing and installing PCI cards.

Removing a PCI card

To remove a PCI card:

1. Disconnect power from the system ([Predisassembly procedures on page 57](#)), remove the side access panel ([Removing the side access panel on page 61](#)), and then remove the PCI card support bracket, if installed ([PCI card support bracket on page 76](#)).

2. Open the PCI card retention clamp. Press the retention clamp levers down to unsnap, and then rotate them up (1).

Figure 5-30 Removing a PCI card

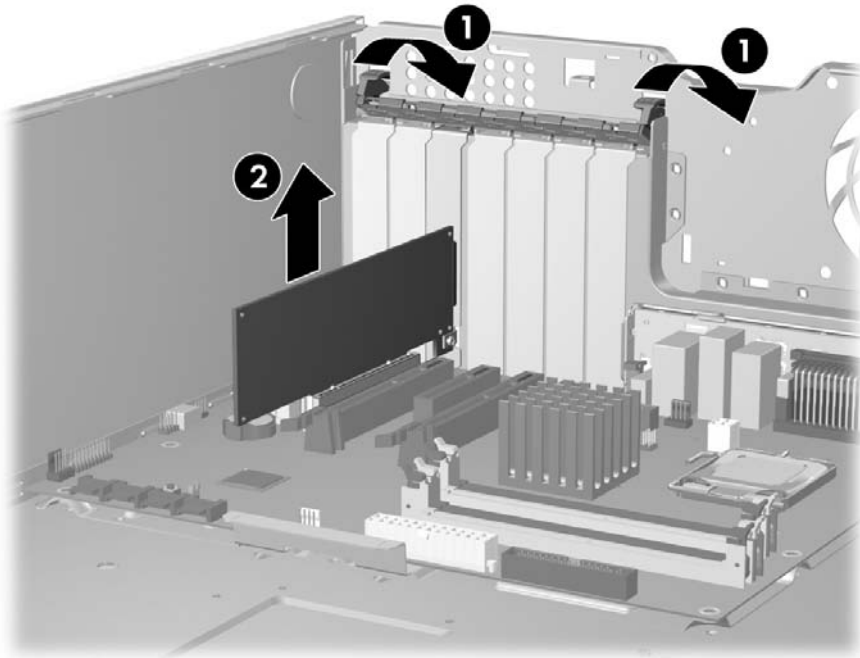

3. Lift the PCI card out of the chassis (2). Store the card in an anti static bag.
4. Install a PCI slot cover and close the PCI retention clamp. If the PCI retention clamp levers do not close, ensure that all cards are properly seated, and then try again.

Installing a PCI card

To install a PCI card:

1. Disconnect power from the system ([Predisassembly procedures on page 57](#)), remove the side access panel ([Removing the side access panel on page 61](#)), and then remove the PCI card support bracket, if installed ([PCI card support bracket on page 76](#)).

2. Open the PCI card retention clamp. Press the retention clamp levers down to unsnap, and then rotate them up (1).

Figure 5-31 Installing a PCI card

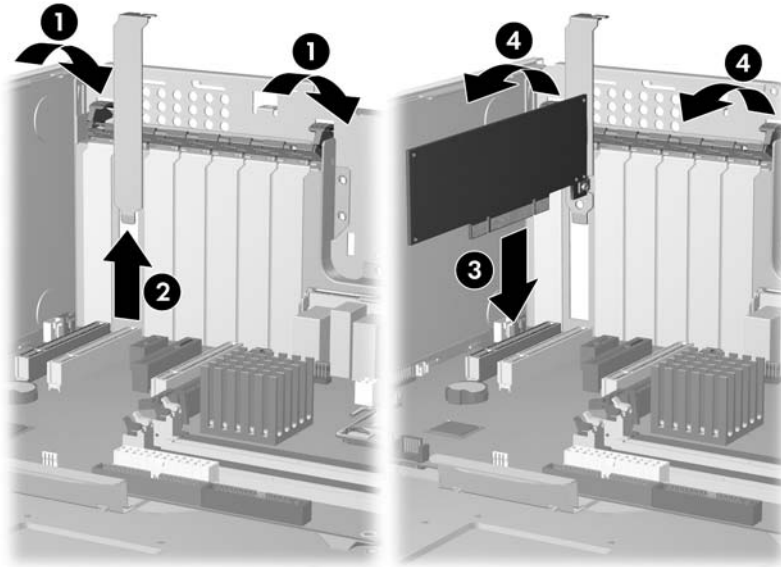

3. Remove the PCI slot cover (2).
4. Align the keyed components of the PCI card with the slot , and then firmly seat the card in the slot (3).
5. Close the PCI retention clamp by rotating the clamp downward and pressing the two green clamp levers from the rear panel of the chassis (4).

IEEE-1394 card (optional)

This section describes how to remove an IEEE-1394 card.

Removing an IEEE-1394 card

To remove an IEEE-1394 card:

1. Disconnect power from the system ([Predisassembly procedures on page 57](#)), remove the side access panel ([Removing the side access panel on page 61](#)), and then remove the front bezel ([Removing the front bezel on page 65](#)).

2. Open the PCI card retention clamp. Press the retention clamp levers down to unsnap, and then rotate them up (1).

Figure 5-32 Removing an IEEE-1394 card

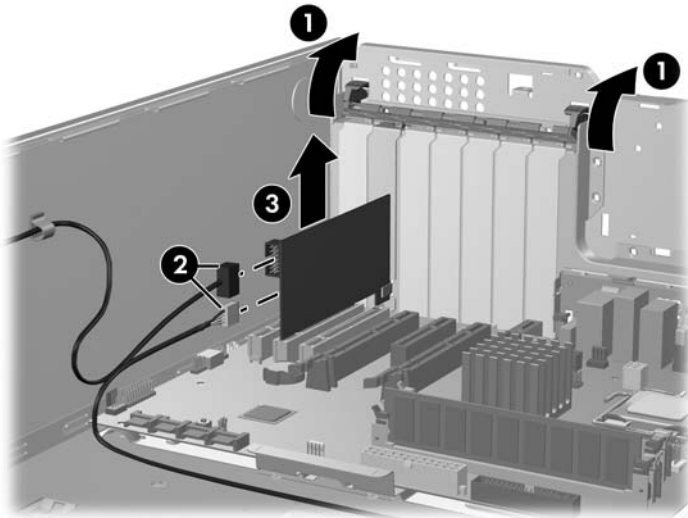

3. Disconnect the front I/O cable and power cable from the card (2).
4. Lift the IEEE-1394 card out of the chassis (3). Store the card in an anti static bag.
5. Install a PCI slot cover and close the PCI card retention clamp. If the PCI levers do not close, ensure that all cards are properly seated, and then try again.

 **NOTE:** To install an IEEE-1394 card, reverse the previous steps.

Front PCI card guide and fan removal (optional)

This unit acts as a front fan housing and card guide. This section describes how to remove and replace the fan housing/card guide and the front fan.

 **NOTE:** The fan is only used for special configurations, but the card guide is used with all full-length add-in cards.

Removing the front PCI card guide and fan

To remove the front PCI card guide and fan:

1. Disconnect power from the system ([Predisassembly procedures on page 57](#)), remove the side access panel ([Removing the side access panel on page 61](#)), and then remove the front bezel ([Removing the front bezel on page 65](#)).

2. Disconnect the fan wire from the connector on the system board and thread it out of the card guide (1).

Figure 5-33 Removing the front fan housing/card guide

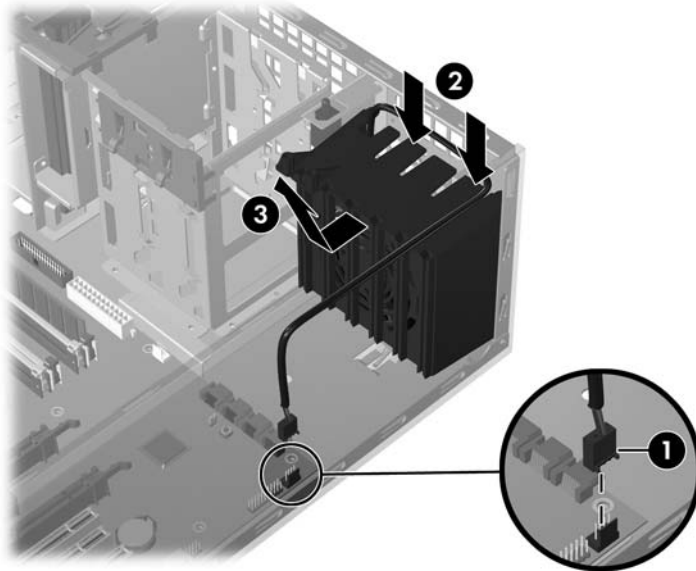

3. Unsnap the fan housing/card guide from the chassis (2) and lift it out of the chassis (3).
4. Remove the fan from the fan housing/card guide by applying outward pressure on the fan housing while pushing the fan out of the housing.

Figure 5-34 Removing the fan from fan housing/card guide

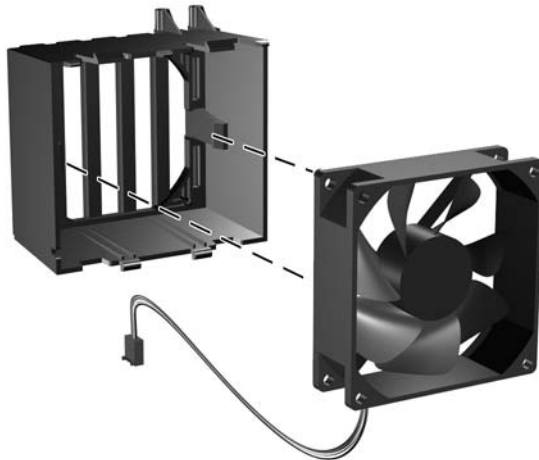

NOTE: To replace the front fan, reverse the previous steps, ensuring that the airflow direction arrow on the side of the fan points to the rear of the chassis.

Battery

This section describes how to remove and install the battery.

The battery that comes with the workstation provides power to the real-time clock and has a minimum lifetime of about three years.

⚠ **WARNING!** This workstation includes a lithium battery. There is a risk of fire and chemical burn if the battery is handled improperly. Do not disassemble, crush, puncture, short external contacts, dispose in water or fire, or expose it to temperatures higher than 60°C (140°F).

⚠ **CAUTION:** Before removing the battery, ensure that the CMOS settings are backed up in case they are lost when the battery is removed. To back up the CMOS settings, select the **Save to Diskette** option in the Computer Setup (F10) Utility.

📄 **NOTE:** Batteries, battery packs, and accumulators should not be disposed of together with general household waste.

Removing the battery

To remove the battery:

1. Disconnect power from the system ([Predisassembly procedures on page 57](#)) and remove the side access panel ([Removing the side access panel on page 61](#)).
2. On the system board, press the release tab of the battery holder.
3. Rotate the battery just enough to get beyond the latch, and then lift it straight up.

Installing the battery

To install the battery:

1. Confirm the polarity (positive or negative) of the battery to position it correctly in the battery holder.
2. Place the battery edge under the plastic housing tab.

Figure 5-35 Removing the battery

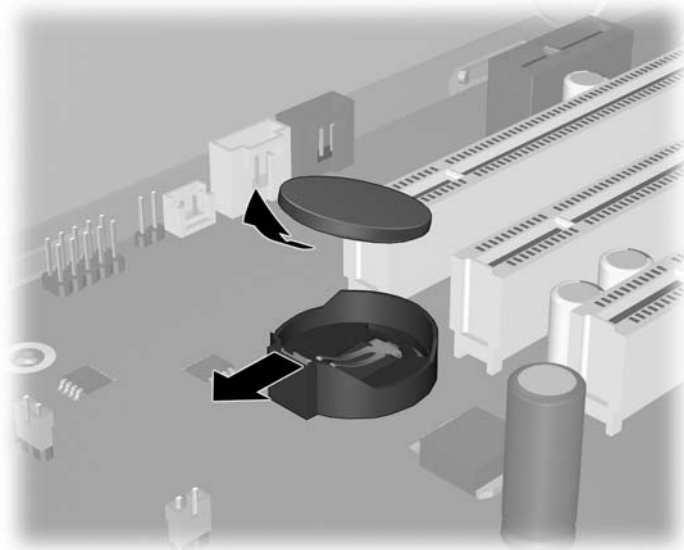

3. Press down on the battery until the metal snaps engage.

Power connections to drives

For help identifying power cables, see the following figure. Ensure that all cables are routed or tied so that they cannot interfere with the processor heatsink fans.

Figure 5-36 Identifying workstation power connectors for a typical configuration

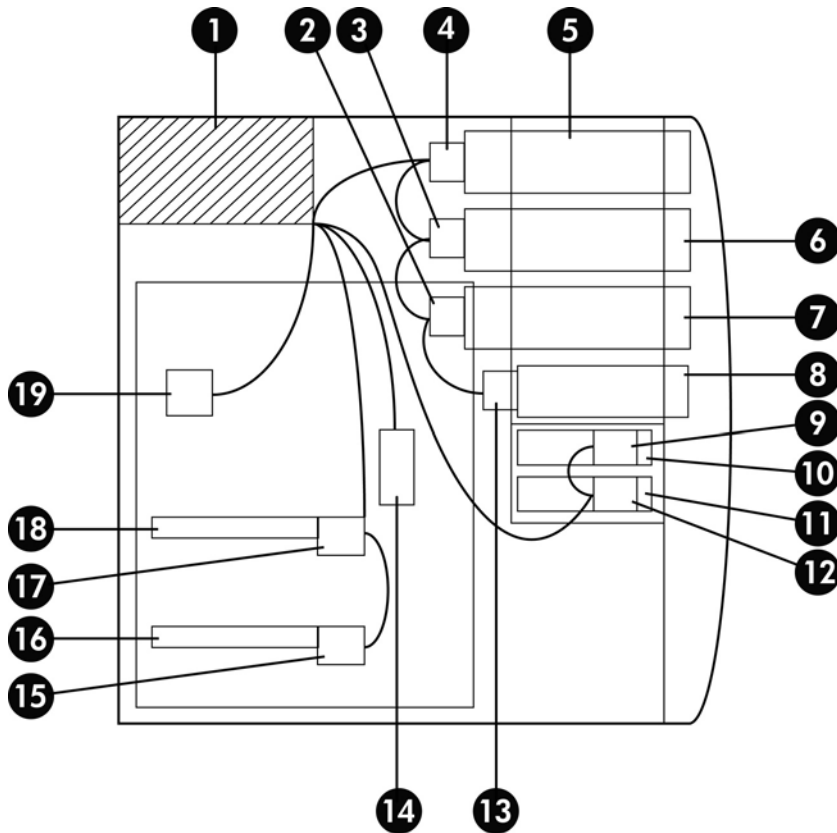

Table 5-8 Workstation power connector description

Item	Description
1	Power supply
2	P8
3	P6/P7
4	P4/P5
5	Optical drive 1
6	Optical drive 2 and Hard drive 4
7	Optical drive 3 and Hard drive 3
8	Diskette
9	P11
10	Hard drive 2
11	Hard drive 1
12	P10

Table 5-8 Workstation power connector description (continued)

Item	Description
13	P9
14	P1
15	P13
16	1394 card
17	P12
18	Graphics card
19	P3

Optical drive (minitower configuration)

This section describes how to remove and install an optical disk drive in a minitower workstation configuration.

Notice for Blu-ray optical drives

If you installed a Blu-ray optical drive, note the following:

Blu-ray movie playback

As Blu-ray is a new format containing new technologies, certain disc, digital connection, compatibility and/or performance issues may arise, and do not constitute defects in the product. Flawless playback on all systems is not guaranteed. In order for some Blu-ray titles to play, they may require a DVI or HDMI digital connection and your display may require HDCP support. HD-DVD movies cannot be played on this workstation.

Blu-ray movie playback compatibility and update

Playing back Blu-ray HDCP (High-bandwidth Digital Content Protection) content such as commercially distributed Blu-ray HD movies requires a fully HDCP compliant path on your computer. The HDCP technology checks compliance of each component in the path from the content on the Blu-ray disc all the way to the display monitor, including but not limited to graphic cards and monitor adapters.

The HP **Z400**, **Z600** and **Z800** Workstations have been designed with this in mind; nearly all configurations with currently available HP Professional Displays are compliant. Older HP **xw4600** and **xw9400** Workstation configurations may not have fully compliant paths based on the installed graphics card and display monitor; HP recommends confirming separately that you have a fully compliant system if commercial content playback is a requirement for your use. HDCP compatibility of your graphics card and monitor can be determined by checking the *QuickSpecs* at <http://www.hp.com/go/productbulletin>.

For the best HDCP performance, HP recommends that you install the latest updates:

1. Blu-ray player firmware
2. Playback application patches
3. Graphics firmware and drivers

Updates are located on the support web site for your specific product at <http://www.hp.com/support/workstations>.

Removing an optical drive (minitower configuration)

1. Disconnect power from the system ([Predisassembly procedures on page 57](#)), remove the side access panel ([Removing the side access panel on page 61](#)), and then remove the front bezel ([Removing the front bezel on page 65](#)).
2. Disconnect the power (1) and data (2) cables from the optical drive.

Figure 5-37 Disconnecting the optical drive cables

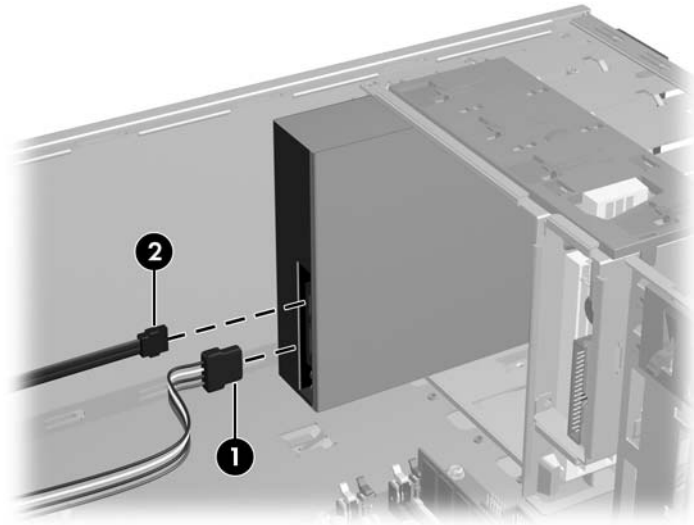

3. Lift the green drive-lock release lever (1) and gently slide the drive out of the chassis (2).

Figure 5-38 Removing the optical drive from the chassis

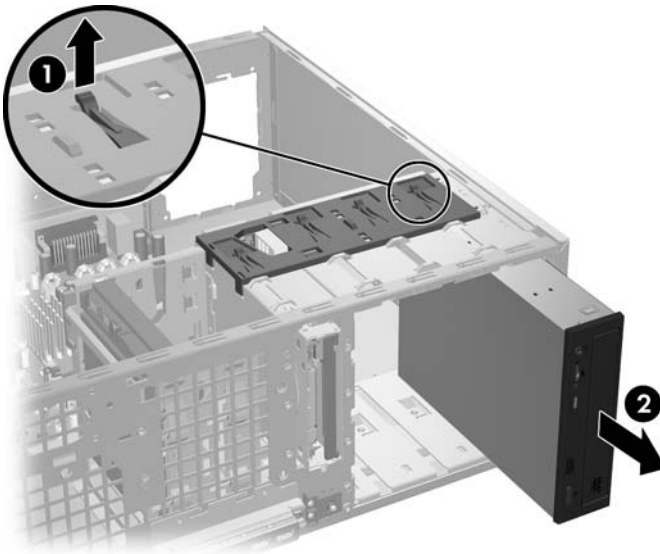

4. After removing the optical drive (1), if you plan to install another drive, remove only the four guide screws from the drive casing (2).

Figure 5-39 Removing the optical drive screws

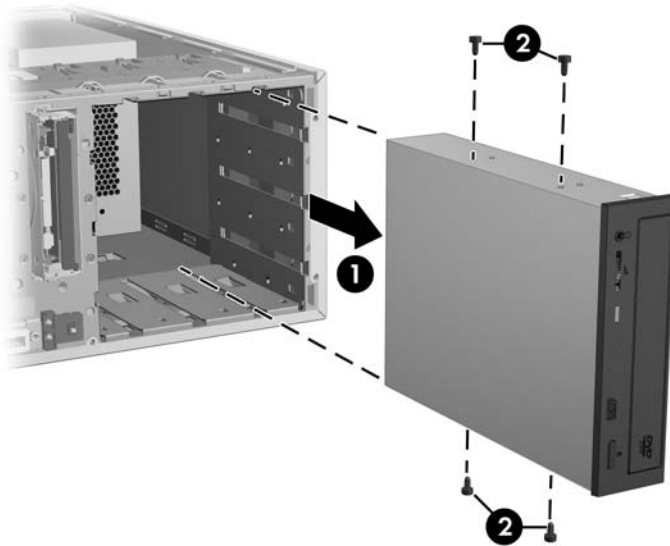

Installing an optical drive (minitower configuration)

1. Disconnect power from the system ([Predisassembly procedures on page 57](#)), remove the side access panel ([Removing the side access panel on page 61](#)), and then remove the front bezel ([Removing the front bezel on page 65](#)).
2. Insert the four black metric M3 guide screws into the drive casing (1).

Figure 5-40 Installing the optical drive

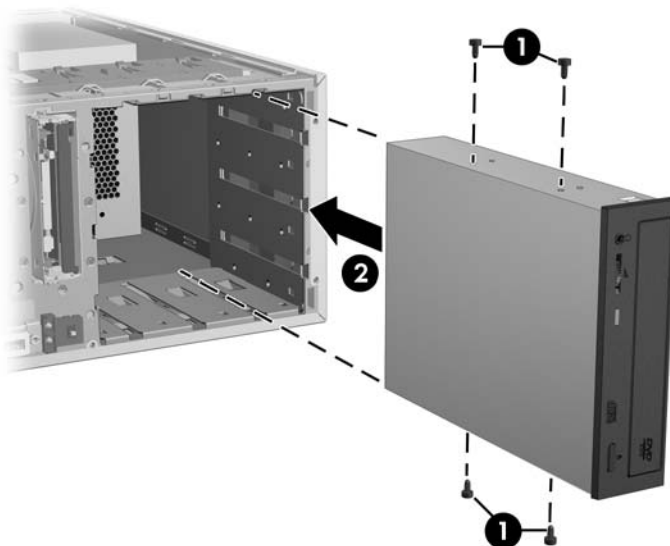

3. Align the screws with the grooves in the drive bay, and then gently slide the drive into the workstation until it snaps into place (2).

△ **CAUTION:** Ensure that the optical drive is secure in the workstation chassis by pulling on the drive to see if it can become easily disengaged. Failure to properly secure the drive can damage the drive when moving the workstation.

4. Connect the power and data cables to the drive and system board.

📝 **NOTE:** SATA optical drives can be configured in a workstation with SATA hard drives. When the SATA Configuration Mode for this workstations is set to:

IDE Mode—Only SATA ports 0 and 2 are functional for any SATA devices.

AHCI Mode—All SATA ports are functional for any SATA devices.

RAID + AHCI Mode—You will not be able to update system BIOS from the SATA optical drive.

Optical drive (desktop configuration)

This section describes how to remove and install an optical drive in the workstation desktop configuration.

Removing an optical drive (desktop configuration)

1. Disconnect power from the system ([Predisassembly procedures on page 57](#)), remove the side access panel ([Removing the side access panel on page 61](#)) and then remove the front bezel ([Removing the front bezel on page 65](#)).
2. Disconnect the data (1), power (2) cables from the drive. The connector colors might be different than shown in the following figure.

Figure 5-41 Disconnecting the optical drive cables

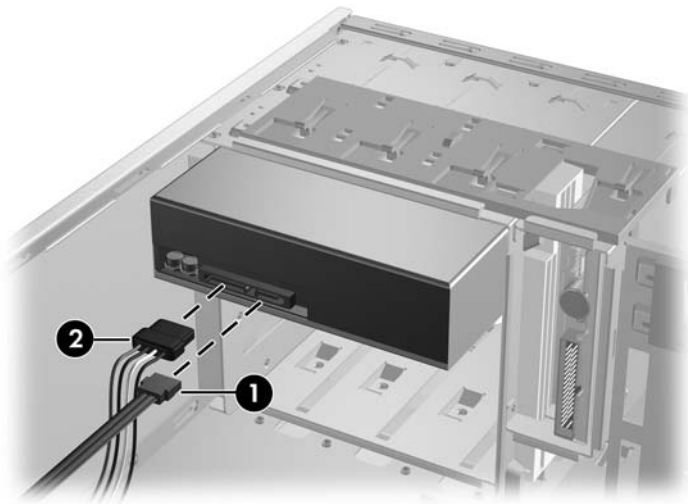

3. Press down on the yellow drive-lock release lever (1) and gently slide the drive out of the chassis (2).

Figure 5-42 Removing the optical drive from chassis

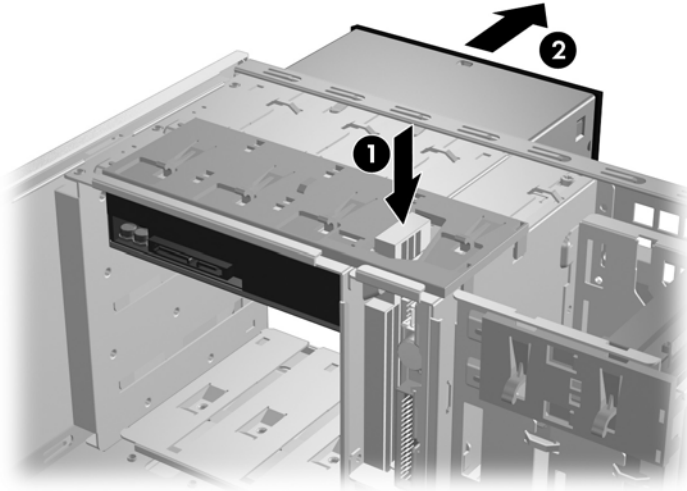

4. After pulling the drive out (1), if you plan to install another drive, remove only the four guide screws from the drive (2).

Figure 5-43 Removing the optical drive screws

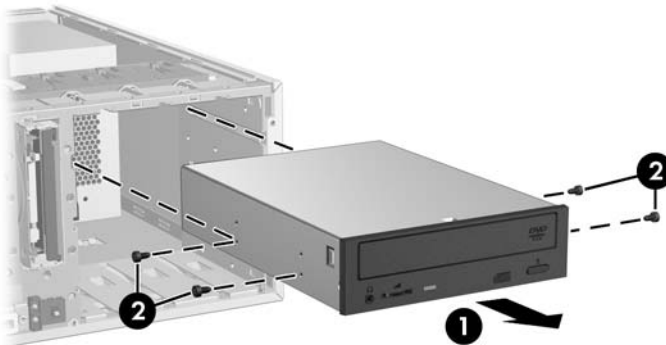

Installing an optical drive (desktop configuration)

1. Disconnect power from the system ([Predisassembly procedures on page 57](#)), remove the side access panel ([Removing the side access panel on page 61](#)), remove the front bezel ([Removing the front bezel on page 65](#)), and then remove the bezel blank ([Removing bezel blanks on page 65](#)) where the drive is being added.

2. Install the four black metric M3 guide screws into the drive (1).

Figure 5-44 Installing the optical drive



3. Align the screws with the grooves in the drive bay and gently slide the drive into the casing until it snaps into place (2).

△ **CAUTION:** Ensure that the optical drive is secure in the workstation chassis by pulling the drive to see if it can become disengaged. Failure to properly secure the drive can cause damage to the drive when moving the workstation.

4. Connect the power and drive cables to the drive and system board.

 **NOTE:** SATA optical drives can be configured in a workstation with SATA hard drives. When the SATA Configuration Mode for this workstations is set to:

IDE Mode—Only SATA ports 0 and 2 are functional for any SATA devices.

AHCI Mode—All SATA ports are functional for any SATA devices.

RAID + AHCI Mode—You will not be able to update system BIOS from the SATA optical drive.

Diskette drive (optional)

This section describes how to remove and install a diskette drive.

Removing a diskette drive

1. Disconnect power from the system ([Predisassembly procedures on page 57](#)), remove the side access panel ([Removing the side access panel on page 61](#)), and then remove the front bezel ([Removing the front bezel on page 65](#)).

2. Disconnect the power (1) and data (2) cables from the back of the diskette drive.

Figure 5-45 Disconnecting the diskette drive cables

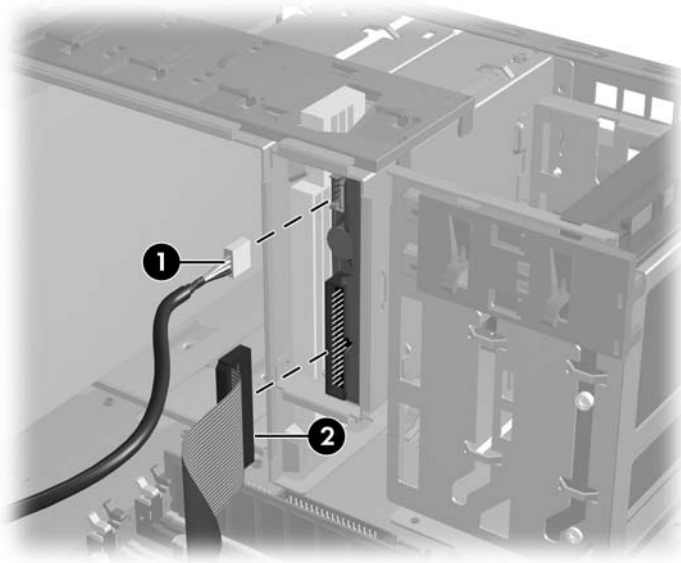

3. Lift the green drive-lock release tab (1) and gently slide the drive out of the chassis at the same time (2).

Figure 5-46 Removing the diskette drive from chassis

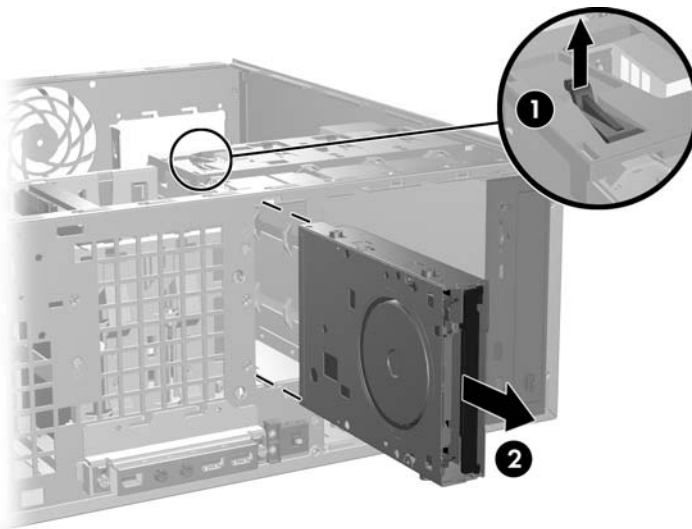

 **NOTE:** To install a diskette drive, reverse the previous steps. You might need to remove the front bezel to install the drive.

SAS hard drive

This section describes how to remove and install a SAS hard drive.

Removing a SAS hard drive

1. Disconnect power from the system ([Predisassembly procedures on page 57](#)), and then remove the side access panel ([Removing the side access panel on page 61](#)).

2. Disconnect the power (1) and data (2) cables from the hard drive.

Figure 5-47 Disconnecting the SAS hard drive cables

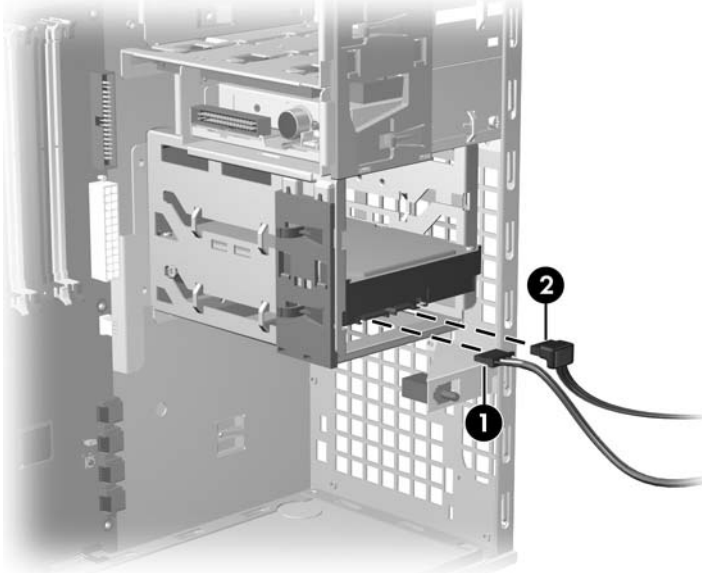

3. Lift the green drive-lock release tab (1), and then slide the hard drive out of the chassis (2).

Figure 5-48 Removing the SAS hard drive

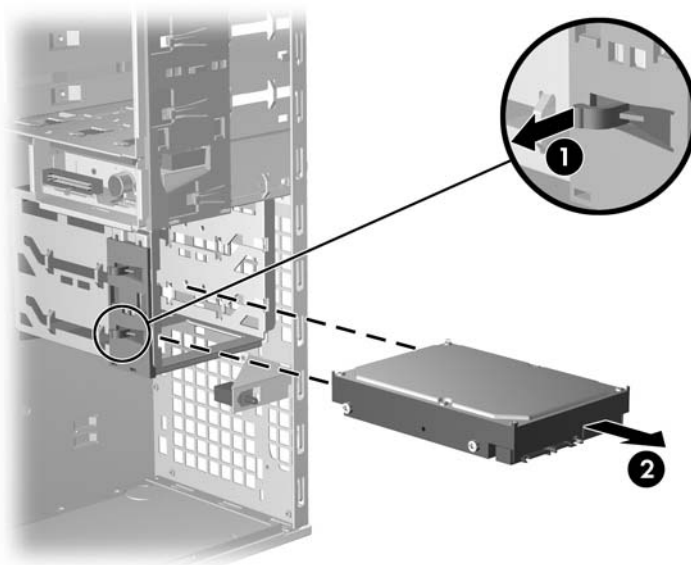

4. Remove the four guide screws from the hard drive and retain them for later use.



Installing a SAS hard drive

1. Disconnect power from the system ([Predisassembly procedures on page 57](#)), and then remove the side access panel ([Removing the side access panel on page 61](#)).
2. Attach a SAS-to-SATA cable adapter to the connector on the SAS hard drive.

Figure 5-49 Attaching the SAS-SATA adapter to the SAS hard drive

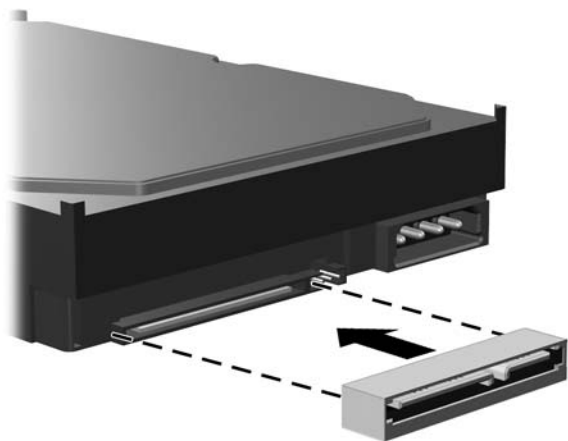

3. Install the four silver, ANSI 6–32 guide screws into the hard drive.



4. Push the drive into the selected bay until it snaps into place (1).

Figure 5-50 Installing the SAS hard drive

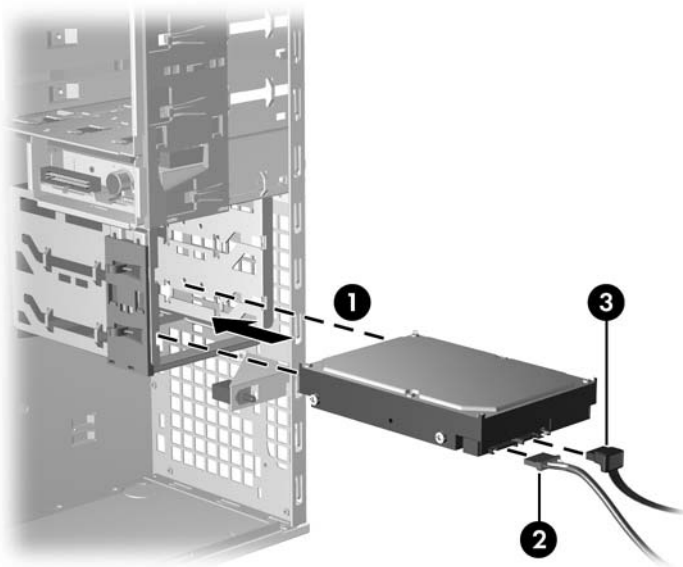

5. Attach the power (2) and data (3) cables to the SAS drive.
6. Insert the SAS controller card into an available PCI slot in the workstation chassis.
7. Connect the data cable from the hard drive (1) to the controller card (2).

Figure 5-51 Connecting the SAS cable to SAS hard drive

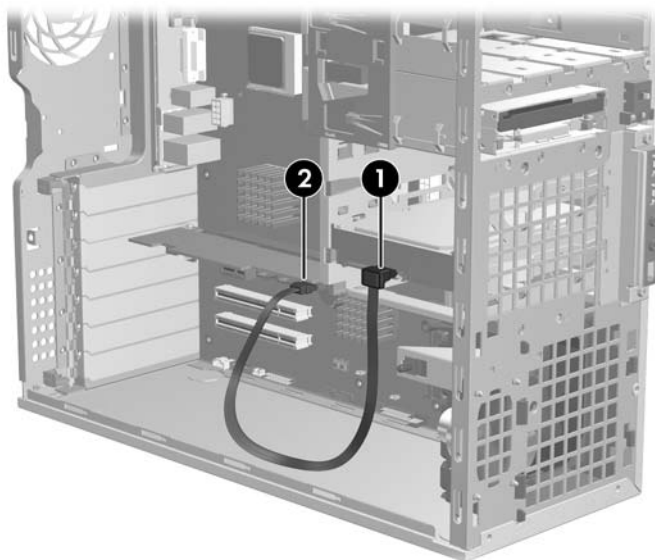

8. If necessary, install the SAS card in an empty PCI Express slot, and then install the LED cable from the card to the system board. You can find the location of this connector on the service label on the inside of the side access panel.

NOTE: To install three or four SAS drives, install the third and fourth drives in the workstation optical drive bays. See [Installing SATA hard drives in the optical drive bays \(optional\) on page 100](#) for instructions.

SATA hard drive

For more information about SATA hard drives and SATA RAID configurations, see [Configuring RAID devices on page 146](#).

This section describes how to remove and install a SATA hard drive.

Removing a SATA hard drive

To remove a SATA hard drive:

1. Disconnect power from the system ([Predisassembly procedures on page 57](#)), and then remove the side access panel ([Removing the side access panel on page 61](#)).
2. Disconnect the data (1) and power (2) cables from the SATA hard drive.

Figure 5-52 Disconnecting the SATA hard drive cables

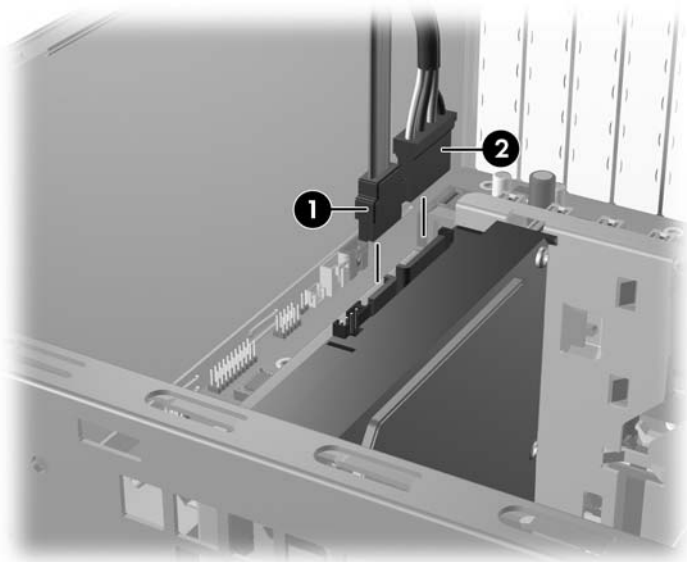

3. Lift the green drive-lock release tab (1) and slide the hard drive out of the chassis (2).

Figure 5-53 Removing the SATA hard drive

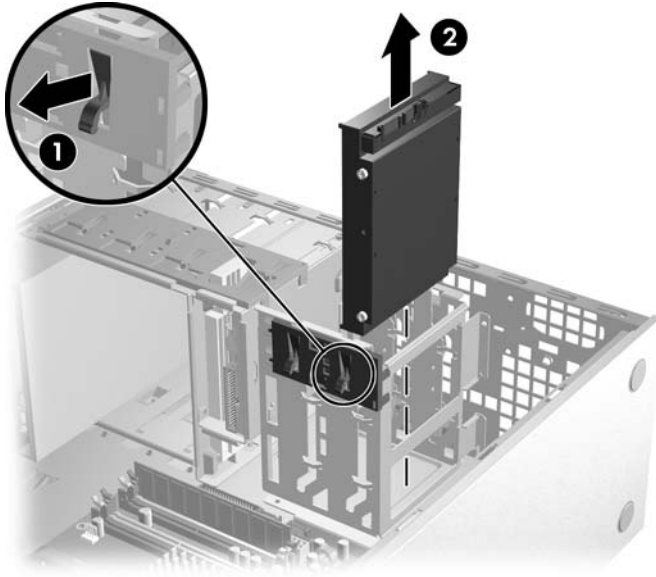

4. Remove the four guide screws from the hard drive and retain them for later use.



Installing a SATA hard drive

To install one or two SATA hard drives:

1. Disconnect power from the system ([Predisassembly procedures on page 57](#)), and then remove the side access panel ([Removing the side access panel on page 61](#)).
2. Select a drive bay in which to install the SATA hard drive.
3. Install the four silver, ANSI 6–32 guide screws into the hard drive.



4. Slide the SATA drive into the selected bay until it snaps into place.

5. Attach the data (1) and power (2) cables to the SATA drive.

Figure 5-54 Connecting the SATA cables to the SATA drive

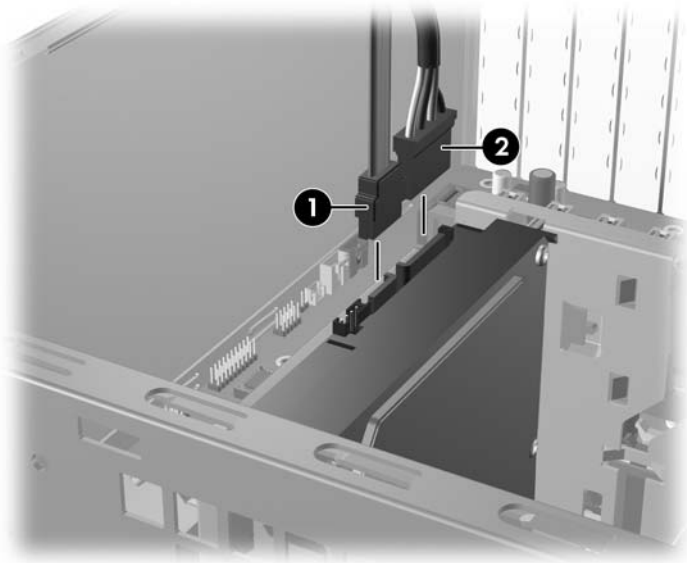

6. For a single SATA drive, connect the SATA 0 data cable from the hard drive (1) to the SATA0 port (2) in the workstation chassis.

For a second SATA drive, connect the SATA 1 data cable from the hard drive to the SATA1 port in the workstation chassis.

Figure 5-55 Connecting the SATA data cable to the workstation SATA port

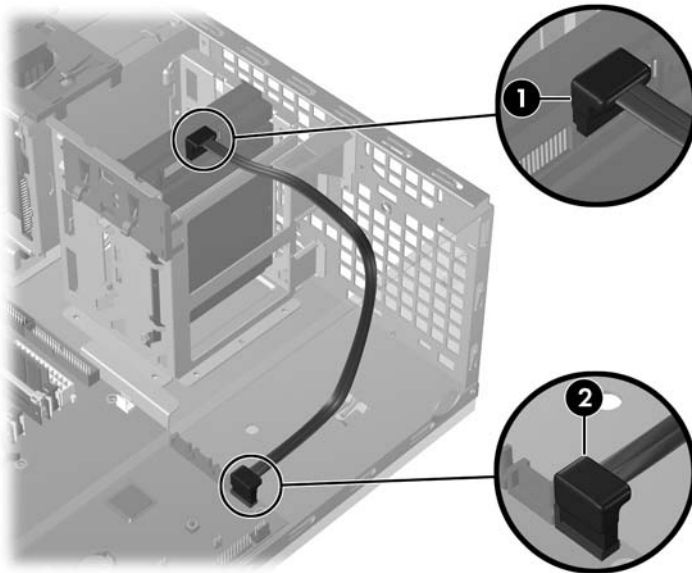

NOTE: To install three or four SATA drives, install the third and fourth drives in the workstation optical bays. See [Installing SATA hard drives in the optical drive bays \(optional\) on page 100](#) for instructions.

Installing SATA hard drives in the optical drive bays (optional)

1. If necessary, remove the EMI shield.
2. Disconnect power from the system ([Predisassembly procedures on page 57](#)), remove the side access panel ([Removing the side access panel on page 61](#)), and then remove the front bezel ([Removing the front bezel on page 65](#)).
3. Place the SATA hard drive in the drive bracket (1), and then install four silver, ANSI 6–32 screws through the bracket and into the hard drive as shown in the following figure (2).

Figure 5-56 Installing the hard drive in bracket

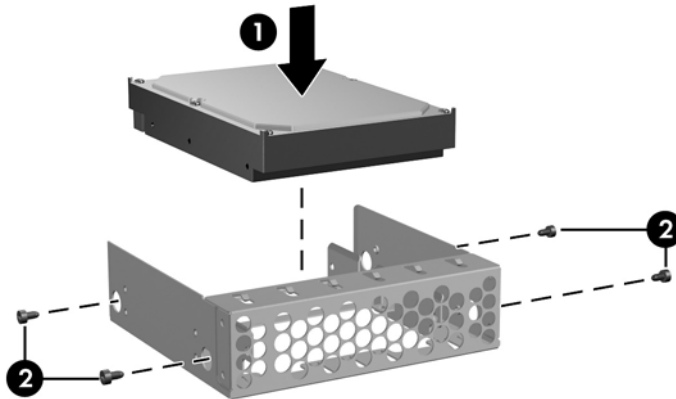

4. Install additional black, metric M3 screws into the bracket (1). Align the screws with the grooves in the optical drive bay, and then slide the drive into the workstation chassis (2).

Figure 5-57 Installing the hard drive in the optical drive bay

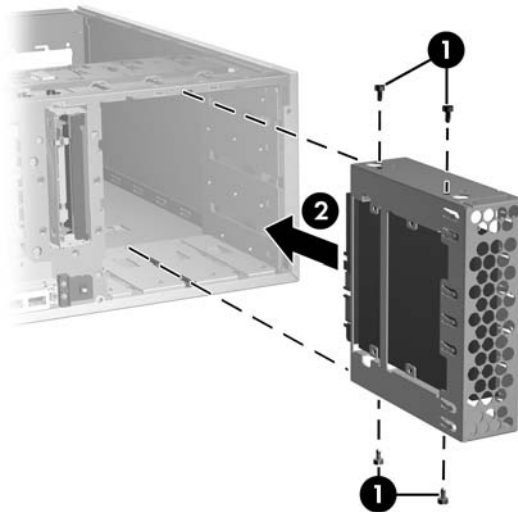

5. Connect the data cable to the hard drive (1) and to the system board (2).

Figure 5-58 Connecting the data cable

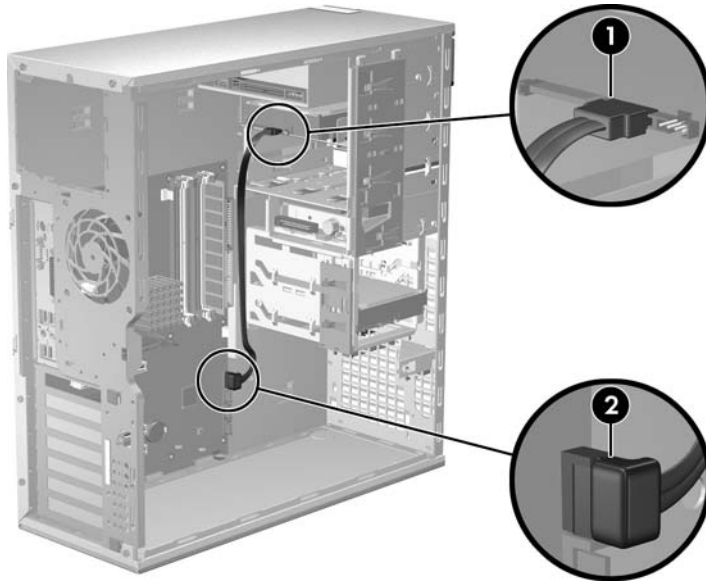

6. Connect the power cable (not shown).

Processor heatsink

This section describes how to remove and install a processor heatsink.

 **NOTE:** Not all heatsinks are the same. Therefore, the heatsink shown in the following figures is an example of what might be installed in your workstation.

Removing the processor heatsink

To remove a heatsink:

1. Power down the workstation ([Predisassembly procedures on page 57](#)), disconnect power from the workstation ([Predisassembly procedures on page 57](#)), and then remove the side access panel ([Removing the side access panel on page 61](#)).

2. Slowly and evenly loosen one pair of diagonally opposite screws (1) from the processor until the screw shanks disengage from the system board. Loosen the remaining pair (2).

△ **CAUTION:** Do not fully loosen one screw, and then move on to the next. Loosen all screws a little at a time, ensuring that the processor remains level.

Figure 5-59 Identify proper screw loosening sequence

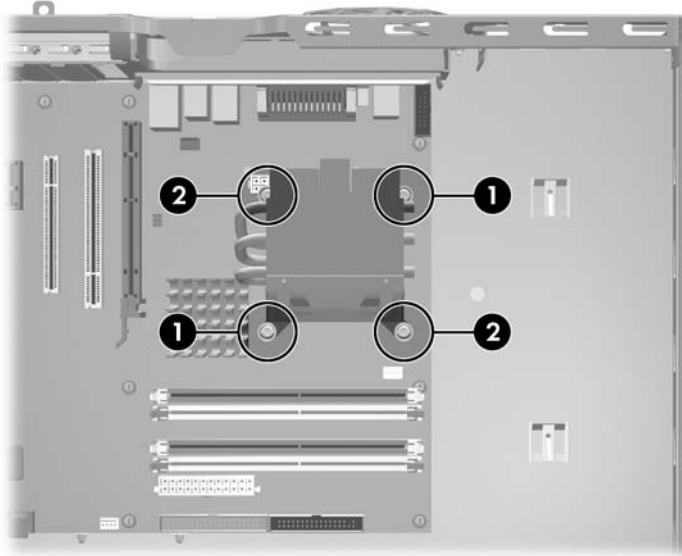

3. Disconnect the processor heatsink fan cable from the system board (1).
4. Gently twist the heatsink to break the thermal grease binding.
5. Lift the processor heatsink out of the chassis (2).

Figure 5-60 Removing the processor heatsink

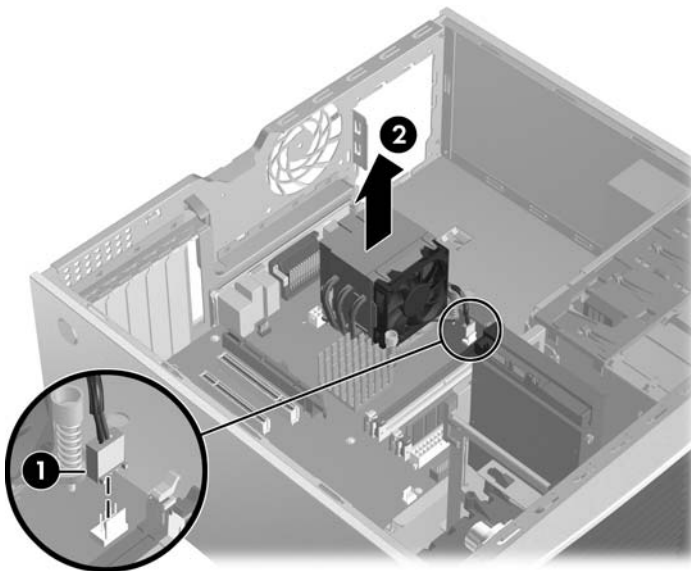

6. Use alcohol and a soft cloth to clean all of the thermal interface residue from the processor and the heatsink.

△ **CAUTION:** Allow the alcohol on the processor and processor heatsink to dry completely.

Installing the processor heatsink

To install a heatsink:

1. Disconnect power from the system ([Predisassembly procedures on page 57](#)), remove the side access panel ([Removing the side access panel on page 61](#)), and then remove the processor heatsink ([Removing the processor heatsink on page 101](#)).
2. If reusing the original heatsink, apply thermal grease to the center of the processor top surface. If using a new processor heatsink, do not apply thermal grease to the processor; the a new heat sink will have grease already applied to the heatsink surface. In this case, discard the thermal grease protective liner from the bottom of the new heatsink before installing.
3. Carefully seat the processor heatsink onto the system board.

△ **CAUTION:** Do not overtighten the heatsink screws. If you overtighten them, you might strip the threads in the system board tray.

4. Carefully tighten the four screws a little at a time, that is, do not fully tighten one screw and move onto the next. If you have a torque-limited driver available, tighten the screws to 6 in-lbs.

△ **CAUTION:** Ensure that the processor remains level as you tighten the screws.

System processor

This section describes how to remove and install a system processor.

Removing a system processor

1. Disconnect power from the system ([Predisassembly procedures on page 57](#)), remove the side access panel ([Removing the side access panel on page 61](#)), and then remove the processor heatsink ([Removing the processor heatsink on page 101](#)).

2. Raise the processor socket lever (1) and open the cover (2).

Figure 5-61 Removing the system processor

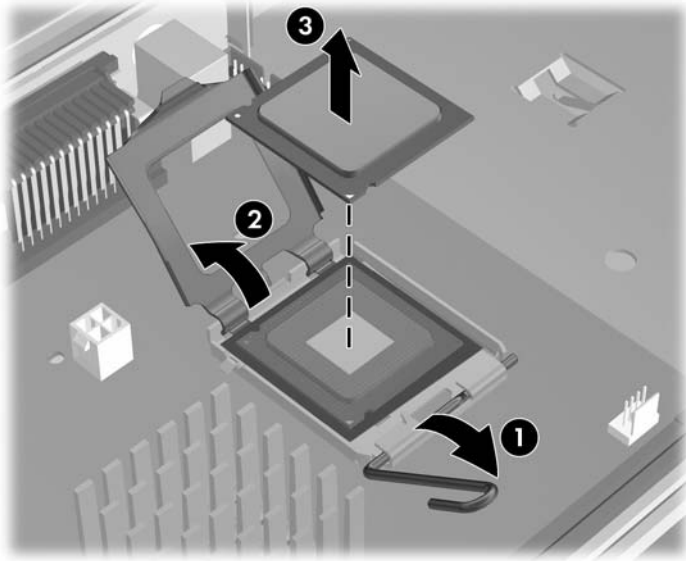

△ **CAUTION:** The processor socket contacts are delicate. To avoid bending the contacts, use extreme care when handling the processor.

3. Pull the processor straight out of the socket (3).

△ **CAUTION:** Do not touch the processor socket pins or the gold pads underneath the processor. Handle the processor by the edges.

 **NOTE:** Store the processor in a static free container in a safe place where it cannot be damaged.

Installing a system processor

1. Disconnect power from the system ([Predisassembly procedures on page 57](#)), remove the side access panel ([Removing the side access panel on page 61](#)), remove the processor heatsink ([Removing the processor heatsink on page 101](#)), and then remove the processor ([Removing a system processor on page 103](#)).

2. Raise the processor socket lever and cover fully.

△ **CAUTION:** The processor socket contacts are delicate. To avoid bending the contacts, use extreme care when installing the processor in the socket.

3. Align the triangle on the top of the processor with the triangle on the corner of the processor socket, and then install the processor into the socket. Ensure that the underside of the processor is level with the top of the processor socket. Close the socket cover and lightly press down on processor while closing the socket lever.

Figure 5-62 Seating the processor

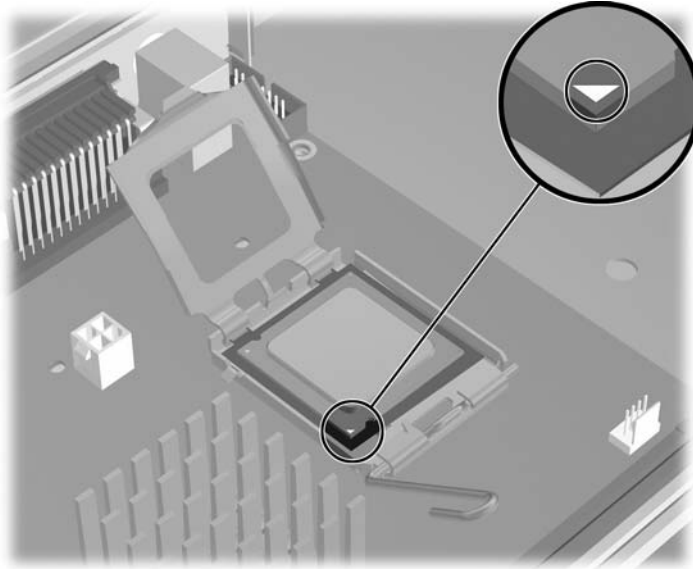

System board

This section describes removing and installing the system board.

Removing the system board

To remove the system board:

1. Disconnect power from the system ([Predisassembly procedures on page 57](#)) and remove the side access panel ([Removing the side access panel on page 61](#)).

 **NOTE:** Although the processor heatsink can remain in place, you might want to remove it for convenience.

2. Remove all expansion boards and graphics cards ([Removing a PCI Express card on page 78](#), [Removing a PCI card on page 80](#)), and then remove the processor heatsink ([Removing the processor heatsink on page 101](#)).

 **TIP:** Make a note of the cable connections before disconnecting them from the system board. For more information, refer to [Power connections to drives on page 86](#).

3. Disconnect all cabling from the system board.

4. Press the release tab as shown in the following illustration (1).

Figure 5-63 Removing the system board

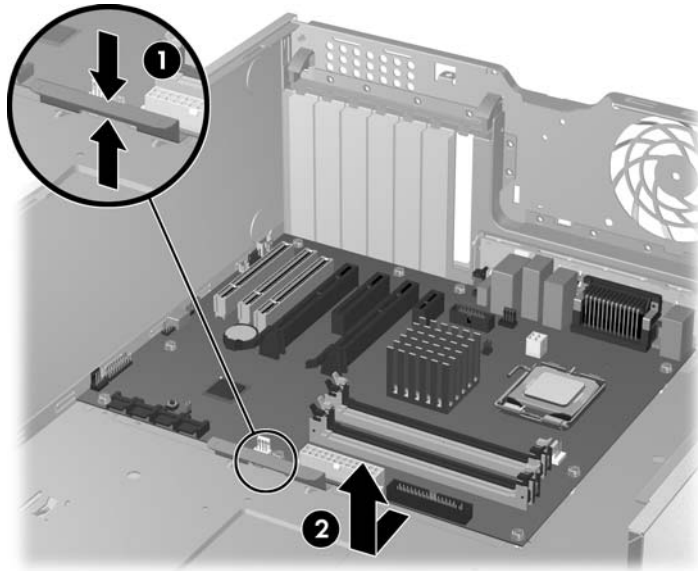

5. Slide the system board toward the front of the chassis and then lift it out of the workstation (2).

Installing the system board

To install the system board:

1. Set the system board in the chassis, slightly away from the rear of the chassis. The mounting hooks will seat in the recesses of the tray so that the tray lies flat on the chassis base.
2. Slide the tray towards the rear of the chassis until the heat sink mounting holes are aligned.
3. Reinstall the processor heatsink, cards, and cables.

Product recycling

HP encourages customers to recycle used electronic hardware, HP original print cartridges, and rechargeable batteries.

For information about recycling HP components or products, see <http://www.hp.com/go/recycle>.

6 System diagnostics and troubleshooting

This chapter describes the tools available for diagnosing and troubleshooting system issues, and includes the following topics:

Topics
HP troubleshooting resources and tools on page 107
Customer Self Help on page 110
Troubleshooting checklist on page 129
LED color definitions on page 130
Self-troubleshooting with HP Vision Field Diagnostics on page 130
POST error messages on page 140

HP troubleshooting resources and tools

This section provides information on the HP Help and Support Center, E-support, and Helpful Hints for troubleshooting.

HP Support Assistant

The HP Support Assistant is a customized HP user interface that enhances the Windows Vista and Win 7 Help and Support Center functions. This customized utility allows you to access specific information about an HP Workstation such as configuration information by clicking **Start > Help and Support**. The interface also provides customized help and support links to the HP Web site related to the HP Workstation.

 **NOTE:** The customized HP Support Assistant is not available on Windows XP Professional x32 or x64 Editions, or on Linux.

HP Help and Support Center

The HP Help and Support Center is a customized HP user interface that enhances the Windows XP Help and Support Center Help feature. This customized utility allows you to access specific information about your HP Workstation such as configuration information by clicking **Start > Help and Support**. The interface also provides customized help and support links to the HP Web site related to your HP Workstation.

 **NOTE:** The customized HP Help and Support Center is not available on Windows XP Professional x64 Edition or on Linux.

 **NOTE:** Currently, HP Help and Support Center does not work on Windows Vista.

E-support

Online access and support resources include Web-based troubleshooting tools, technical knowledge databases, driver and patch downloads, online communities, and product change notification services.

The following Web sites are also available to you:

- <http://www.hp.com>—Provides useful product information.
- http://www.hp.com/support/workstation_manuals—Provides the latest online documentation.
- <http://www.hp.com/go/workstationsupport>—Provides technical support information for workstations.
- <http://www.hp.com/support>—Provides a listing of the worldwide technical support phone numbers. Access the telephone numbers by visiting the Web site, then select your region, and click **Contact HP** in the upper-left corner.
- http://www.hp.com/support/workstation_swdrivers—Provides access to software and drivers for workstations.

Troubleshooting a problem

To help you troubleshoot problems with your system, HP provides the Business Support Center (BSC). The BSC is a portal to an extensive selection of online tools. To access BSC and troubleshoot a problem with the workstation, complete the following:

1. Visit <http://www.hp.com/go/workstationsupport>.
2. Under the **Business Support Center** menu on the left, select **Troubleshoot a problem**.
3. Under **Select your product** (center window), select **Workstations** (under **personal computing**).
4. Under **Select your product**, continue with selections as appropriate to the workstation series and model, and to the problem you are troubleshooting.

Instant Support and Active Chat

HP Instant Support is a set of Web-based support tools that automate and speed up the resolution of desktop computing, tape storage, and printing problems.

Active Chat enables you to electronically submit a support ticket to HP over the Web. When you submit a support ticket, Active Chat collects information about the computer and pass it to an online support specialist. The collection of information might take up to 30 seconds depending on the computer configuration. When you submit a support ticket, you receive a confirmation message containing your case ID, the support hours for your location, and the estimated time of response.

For more information about HP Instant Support and Active Chat and how to use them, visit http://www.hp.com/hps/hardware/hw_professional.html.

 **NOTE:** This feature is not available on Windows XP Professional x64 Edition or on Linux.

Customer Advisories, Customer and Security Bulletins, and Customer Notices

To find advisories, bulletins, and notices:

1. Visit <http://www.hp.com/go/workstationsupport>.
2. Select the desired product.

3. Under **Resources for <your selected product>**, select **See more....**
4. Under **Self-Help resources:** in the center of the window, choose the desired action and appropriate information in the scroll list to view the index.

Product Change Notifications

Product Change Notifications (PCNs) are proactive notifications for product changes occurring within a 30-60 day window of the effective date of the change in the manufacturing process. PCNs give customers advanced notice of changes to their product, such as an updated BIOS version that they may need to qualify prior to the change taking place. The latest PCNs are located at: <http://www.hp.com/go/workstationsupport>.

Helpful hints

If you encounter a problem with the workstation, monitor, or software, the following provides a list of general suggestions that help you isolate and focus on the problem before taking further action.

At startup

- Verify that the workstation and monitor are plugged into a working electrical outlet.
- Remove all diskettes, optical disks, and USB drive keys from the drives before powering on the workstation.
- Verify that the workstation is turned on and the green power light is on.
- If you have installed an operating system other than the factory-installed operating system, check to be sure that it is supported on your system by visiting <http://www.hp.com/go/quickspecs>.
- Verify that the monitor is turned on and the green monitor light is on.
- Turn up the brightness and contrast controls of the monitor if the monitor is dim.
- If the workstation has multiple video sources and only a single monitor, the monitor must be connected to the source selected as the primary VGA adapter. During startup, the other monitor connectors are disabled; if the monitor is connected to one of these ports, it will not function after Power-on Self Test (POST). You can select the default VGA source in Computer Setup (F10).

During operation

- Look for blinking LEDs on the front of the workstation. The blinking lights are error codes that will help you diagnose the problem. Refer to the *Diagnostic lights and audible (beep) codes* section of this document for information on interpreting diagnostic lights and audible codes.
- Press and hold any key. If the system beeps, then your keyboard is operating correctly.
- Check all cables for loose or incorrect connections.
- Wake the workstation by pressing any key on the keyboard or the power button. If the system remains in suspend mode, shut down the system by pressing and holding the power button for at least four seconds, then press the power button again to restart the system. If the system does not shut down, unplug the power cord, wait a few seconds, then plug it in again. If it does not restart, press the power button to start the workstation.
- Reconfigure the workstation after installing a non–plug and play expansion board or other option. Refer to the *Hardware installation problems* section of this document for instructions.
- Be sure that all required device drivers have been installed. For example, if you have connected a printer, you must install a printer driver.

- If you are working on a network, plug another workstation with a different cable into the network connection. There might be a problem with the network plug or cable.
- If you recently added new hardware, remove the hardware and verify if the workstation functions properly.
- If you recently installed new software, uninstall the software and verify if the workstation functions properly.
- If the screen is blank, plug the monitor into a different video port on the workstation if one is available. Alternatively, replace the monitor with a monitor that you know is working properly.
- Upgrade the BIOS. A new release of the BIOS might have been released that supports new features or fixes your problem.
- For more detailed information, see the troubleshooting chapter in the *Maintenance and Troubleshooting Guide* at http://www.hp.com/support/workstation_manuals.

Customizing the monitor display

You can manually select or change the monitor model, refresh rates, screen resolution, color settings, font sizes, and power management settings. To do so, right-click the desktop, then click **Properties** to change display settings. For more information, see the online documentation provided with the graphics controller utility or the documentation that came with your monitor.

Customer Self Help

Help and Support Center

The HP Help and Support Center (HSC) provides online access to technical support information, software updates and downloads, diagnostic tools, and HP support contact information.

To open the online HSC from your desktop, select **Start>Help and Support**.

HSC contains four support areas:

- HP Product Information (requires Internet access)—Links to the HP Technical Support website for your product. You can access all related documentation, downloads and updates, tools, and more.
- HP Software and Driver Downloads (requires Internet access)—Links to software downloads and updates specific to HP products.
- HP Support Tools (requires Internet access)—Links to self-help tools and diagnostics offered by HP Instant Support Professional Edition.
- Contact HP for Support (does not require Internet access)—Provides two options:
 - Chat with an expert online (requires Internet access)—Provides a tool to communicate with a support specialist online through Active Chat.
 - Call a support agent—Provides hardware details about your workstation and HP support phone numbers worldwide.

HP SoftPaq Download Manager

The HP SoftPaq Download Manager enables you to download software updates for your workstation from the HP support site. To use the download manager:

1. Go to http://www.hp.com/support/workstation_swdrivers.
2. Select your workstation model, operating system, and language, and then click **Find Available SoftPaqs**. All available SoftPaqs matching the selected criteria are displayed.
3. Select the updates you want to download.
4. Select **Download**.

Diagnostic LED codes

 **NOTE:** Workstation beeps are emitted from the onboard piezo speaker, the chassis speaker. The flashing lights and beeps repeat for five cycles. After five cycles, only the flashing lights repeat.

Table 6-1 Diagnostic LED codes

Chassis indicator LEDs	
Power LED and sound activity	Diagnosis and service action
None	<p>Workstation does not power on. Press the power button. If the hard drive LED is GREEN, then:</p> <ol style="list-style-type: none">1. Remove expansion cards one at a time.2. Replace the system board. <p>OR</p> <p>Press the power button. If the hard drive LED does not illuminate, then:</p> <ol style="list-style-type: none">1. Verify that the workstation is plugged into a working AC outlet.2. Open the access panel and verify that the power button harness is properly connected to the inline front panel I/O device assembly connector.3. Verify that the power supply cables are properly connected to the system board.4. Verify power supply functionality.<ol style="list-style-type: none">a. Disconnect AC power.b. Remove all internal power supply cables from the system board.c. Plug in AC power.<ul style="list-style-type: none">◦ If the power supply fan spins and the BIST LED illuminates, then the power supply is good. Replace the system board.◦ If the power supply fan does not spin or the BIST LED does not illuminate, then replace the power supply.

Table 6-1 Diagnostic LED codes (continued)

Chassis indicator LEDs	
Power LED and sound activity	Diagnosis and service action
Blinks red 2 times (once per second), then a 2-second pause, and then 2 beeps	Thermal shutdown has occurred: <ol style="list-style-type: none">1. Ensure that the workstation air vents are not blocked and the cooling fan is running.2. Open the access panel, press power button, and determine whether the processor fan spins. If it does not spin, ensure the fan cable is plugged into the system board. Ensure that the fan is properly seated.3. If the fan is plugged in and seated but not spinning, then replace processor fan.4. Reseat the processor heatsink and verify that the fan assembly is properly attached.
Blinks red 3 times (once per second), then a 2-second pause, and then 3 beeps	Processor not installed <ol style="list-style-type: none">1. Install processor.2. Reseat processor.
Blinks red 4 times (once per second), then a 2-second pause, and then 4 beeps	Power supply failure. <ol style="list-style-type: none">1. Open the access panel, and be sure the four-wire power supply cable is properly connected to the system board.2. Locate a faulty device by removing all devices and then reinstalling one at a time until the workstation fails. Replace the device causing the failure. Continue adding devices to ensure all are functioning properly.3. Verify the power supply functionality.<ol style="list-style-type: none">a. Disconnect AC power.b. Remove all internal power supply cables from the system board.c. Plug in AC power.<ul style="list-style-type: none">• If the power supply fan spins and the BIST LED illuminates, then the power supply is good. Replace the system board.• If the power supply fan does not spin or the BIST LED does not illuminate, replace the power supply.
Blinks red 5 times (once per second), then a 2-second pause, and then 5 beeps	Pre-video memory error. <ol style="list-style-type: none">1. Reseat memory modules.2. Replace memory modules one at a time to find the faulty module.3. Replace third-party modules with HP memory.4. Replace the system board.
Blinks red 6 times (once per second), then a 2-second pause, and then 6 beeps	Pre-video graphic card error. For systems with integrated graphics, replace the system board. For systems with graphic cards: <ol style="list-style-type: none">1. Reseat the graphic card. Power on the workstation.2. Replace the graphic card.3. Replace the system board.
Blinks red 7 times (once per second), then a 2-second pause, and then 7 beeps	System board failure (ROM detected a failure before video). Replace system board.

Table 6-1 Diagnostic LED codes (continued)

Chassis indicator LEDs	
Power LED and sound activity	Diagnosis and service action
Blinks red 8 times (once per second), then a 2-second pause, and then 8 beeps	Invalid ROM based on bad checksum. <ol style="list-style-type: none"> 1. Reflash the ROM. 2. Replace the system board.
Blinks red 9 times (once per second), then a 2-second pause, and then 9 beeps	System powers on, but is unable to boot. <ol style="list-style-type: none"> 1. Replace the system board. 2. Replace the processor.

Troubleshooting scenarios and solutions

This section presents an extensive overview of various troubleshooting scenarios and includes possible solutions for each.

Solving minor problems

Table 6-2 Minor problems

Problem	Cause	Possible Solution
Workstation appears frozen and does not shut down when the power button is pressed.	Software control of the power switch is not functional.	<ol style="list-style-type: none"> 1. Press and hold the power button for at least four seconds until the workstation shuts down. 2. Disconnect the electrical plug from outlet. 3. Restart the workstation.
Workstation seems to be frozen.	Program in use has stopped responding to commands.	<ol style="list-style-type: none"> 1. Attempt the normal Windows shutdown procedure. 2. Restart the workstation using the power button.
Workstation date and time display is incorrect.	Real-time clock (RTC) battery might need replacement.	<ol style="list-style-type: none"> 1. Reset the date and time under the Control Panel. 2. Replace the RTC battery.
Workstation appears to pause periodically.	Network driver is loaded and no network connection is established.	Establish a network connection, or use the Computer Setup (F10) Utility or the Microsoft Windows Device Manager to disable the network controller.
Cursor does not move using the arrow keys on the keypad.	The Num Lock key might be on.	Press the Num Lock key. The Num Lock key can be disabled (or enabled) in the Computer Setup (F10) Utility.
Poor performance is experienced.	Processor is hot.	<ol style="list-style-type: none"> 1. Be sure airflow to the workstation is not blocked. 2. Be sure the fans are connected and working properly (some fans only operate when needed). 3. Be sure the processor heatsink is installed properly.
	Hard drive is full.	Transfer data from the hard drive to create more space on the hard drive.

Table 6-2 Minor problems (continued)

Problem	Cause	Possible Solution
Workstation powered off automatically and the Power LED flashes red 2 times (once every second), followed by a 2-second pause, and then two simultaneous beeps sounded.	Processor thermal protection activated. A fan might be blocked or not turning. OR The processor heatsink is not properly attached to the processor.	<ol style="list-style-type: none"> 1. Be sure workstation air vents are not blocked and the cooling fan is running. 2. Open the access panel, press the power button, and then verify that the processor fan spins. If not spinning, ensure that the fan cable is plugged into the system board header. Ensure that the fan is fully/properly seated or installed. 3. Replace the processor fan. 4. Reseat processor heatsink and verify that the fan assembly is properly attached.
System does not power on, and the LEDs on the front of the workstation are not flashing.	System is unable to power on.	<p>Press and hold the power button for less than 4 seconds. If the hard drive LED turns green, then:</p> <ol style="list-style-type: none"> 1. Remove the expansion cards. 2. Replace the system board. <p>OR Press and hold the power button for less than 4 seconds. If the hard drive LED does not illuminate, then:</p> <p>Press and hold the power button for <i>less than</i> 4 seconds. If the hard drive LED does not illuminate, then:</p> <ol style="list-style-type: none"> 1. Verify that the workstation is plugged into a working AC outlet. 2. Open the access panel and verify that the power button harness is properly connected to the inline front panel I/O device assembly connector. 3. Verify that the power supply cables are properly connected to the system board. 4. Verify the power supply functionality: <ol style="list-style-type: none"> a. Disconnect AC power. b. Remove all internal power supply cables from the system board. c. Plug in AC power. <ul style="list-style-type: none"> • If the power supply fan spins and the BIST LED illuminates, then the power supply is good. Replace the system board. • If the power supply fan does not spin or the BIST LED does not illuminate, replace the power supply.

Solving power supply problems

This section presents power supply troubleshooting scenarios.

Testing power supply

Before replacing the power supply, use the Built-In Self-Test (BIST) feature to learn if the power supply still works.

To test the power supply:

1. Unplug the AC power.
2. Disconnect all internal power supply cables from the system board.
3. Plug in AC power.
 - If the green BIST LED (illustrated below) on the rear of the workstation is illuminated *and* the fan is spinning, the power supply is functional.
 - If the green BIST LED is not illuminated **or** the fan is not spinning, replace the power supply.

Figure 6-1 Testing power supply with BIST LED

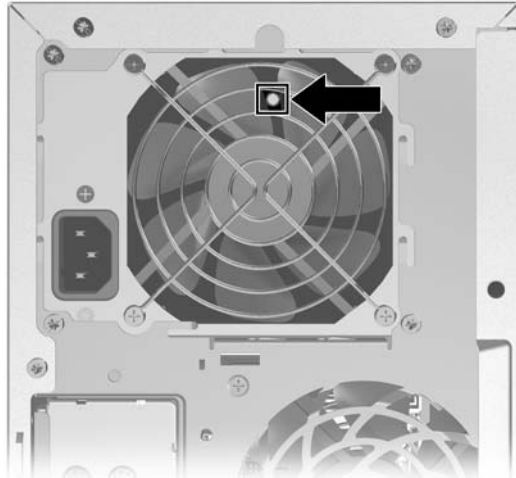

Table 6-3 Power supply problems

Problem	Cause	Solution
Power supply shuts down intermittently.	Power supply fault.	Replace the power supply.

Table 6-3 Power supply problems (continued)

Problem	Cause	Solution
Workstation powered off automatically and the Power LED flashes red 2 times (once every second), followed by a 2-second pause.	Processor thermal protection activated.	1. Be sure that the workstation air vents are not blocked and the cooling fan is running.
	A fan might be blocked or not turning. OR The processor heatsink fan assembly is not properly attached to the processor.	2. Open the access panel, press the power button, and determine whether the processor fan spins. If the processor fan is not spinning, be sure the fan's cable is plugged into the system board header. Be sure the fan is properly seated or installed. 3. Replace the processor fan. 4. Reseat processor heatsink and verify that the fan assembly is properly attached.
Power LED flashes red (once every 2 seconds).	Power failure (power supply is overloaded).	1. Determine whether a device is causing the problem by removing all attached devices. Power on the system. If the system enters the POST, then power off and replace one device at a time and repeat this procedure until a failure occurs. Replace the device causing the failure. Continue adding devices one at a time to ensure all devices are functioning properly. 2. Verify the power supply functionality. <ul style="list-style-type: none"> a. Disconnect AC power. b. Remove all internal power supply cables from the system board. c. Plug in AC power. <ul style="list-style-type: none"> • If the power supply fan spins and the BIST LED illuminates, then the power supply is good. Replace the system board. • If the power supply fan does not spin or the BIST LED does not illuminate, replace the power supply.

Solving diskette problems

Table 6-4 Diskette problems

Problem	Cause	Solution
Diskette drive light stays on.	Diskette is damaged.	Right-click Start , select Explore , and then select a drive. Select File>Properties>Tools . Under Error-checking, select Check Now .
	Diskette is incorrectly inserted.	Remove and reinsert diskette.
	Files on diskette are damaged.	Verify the program diskettes.
Drive not found.	Drive cable is not properly connected.	Reconnect power cable. Be sure that all four pins are connected.
	Cable is loose.	Reseat diskette drive data and power cables.
	Removable drive is not seated properly.	Reseat the drive.
Diskette drive cannot write to a diskette.	Diskette is not formatted.	Format the diskette.
	Diskette is write-protected.	Use another diskette or remove the write protection.

Table 6-4 Diskette problems (continued)

Problem	Cause	Solution
	Writing to the wrong drive.	Verify the drive letter in the path statement.
	Not enough space is left on the diskette.	Use another diskette.
	Diskette write-control is enabled.	Use the Computer Setup (F10) Utility to verify the storage security feature disabled settings.
	Diskette is damaged.	Replace the damaged disk.
Cannot format diskette.	Invalid media reported.	When formatting a disk in MS-DOS, you might need to specify diskette capacity. For example, to format a 1.44-MB diskette, enter the following command at the MS-DOS prompt: FORMAT A: /F:1440
A problem has occurred with a disk transaction.	The directory structure is bad, or there is a problem with a file.	Right-click Start , select Explore , and then select a drive. Select File>Properties>Tools . Under Error-checking, select Check Now .
Diskette drive cannot read a diskette.	Diskette is not formatted.	Format the diskette.
	You are using the wrong diskette type for the drive type.	Verify the type of drive that you are using and use the correct diskette type.
	You are reading the wrong drive.	Verify the drive letter in the path statement.
	Diskette is damaged.	Replace the diskette with a new one.
"Invalid system disk" message is displayed.	A diskette that does not contain the system files needed to start the workstation has been inserted into the drive.	When drive activity stops, remove the diskette and press the Spacebar . The workstation should start up.
	Diskette error has occurred.	Restart the workstation by pressing the power button.
Cannot Boot to Diskette.	Diskette is not bootable.	Replace with a bootable diskette.
	Diskette boot has been disabled in Computer Setup.	Run Computer Setup and enable diskette boot in Storage>Boot Order .
	Removable media boot has been disabled in Computer Setup.	Run Computer Setup and enable Removable Media Boot in Storage>Storage Options .
	Diskette MBR validation is enabled.	Run the Computer Setup (F10) Utility and disable Diskette MBR Validation in Storage>Storage Options .

Solving hard drive problems

Table 6-5 Hard drive problems

Problem	Cause	Solution
Hard drive error occurs.	Hard disk has bad sectors or has failed.	Use a utility to locate and block usage of bad sectors. If necessary, reformat the hard disk. Or, if the drive is detected by the BIOS, then run DPS Self-test .

Table 6-5 Hard drive problems (continued)

Problem	Cause	Solution
Disk transaction problem.	The directory structure is bad, or there is a problem with a file.	Right-click Start , select Explore , and select a drive. Select File>Properties>Tools . Under Error-checking, select Check Now .
Drive not found (identified).	Loose cable.	Verify cable connections.
	The system might not have automatically recognized a newly installed device.	<ol style="list-style-type: none"> 1. Run the Computer Setup (F10) Utility. 2. If the system still does not recognize the new device, verify that the device is listed in the Computer Setup (F10) Utility. If it is listed, the probable cause is a driver problem. If it is not listed, the probable cause is a hardware problem. 3. If this drive is newly installed, enter Setup and try adding a POST delay under Advanced>Power-On.
	Drive jumper settings might be incorrect.	If the drive is a secondary drive that has just been installed on the same cable as the primary drive, verify that the jumpers for both drives are set correctly.
Nonsystem disk or NTLDR missing message.	Drive responds slowly immediately after power-up.	Run the Computer Setup (F10 utility, and then increase the POST Delay in Advanced>Power-On Options .
	System is trying to start from a nonbootable diskette.	Remove the diskette from the diskette drive.
System files missing or not properly installed.	System is trying to start from a damaged hard drive.	<ol style="list-style-type: none"> 1. Insert a bootable diskette into the diskette drive and restart the workstation. 2. If the hard drive is still inaccessible and MBR Security is enabled, try restoring the previously saved MBR image by entering Setup, and then selecting Security>Restore Master Boot Record.
	System files missing or not properly installed.	<ol style="list-style-type: none"> 1. Insert a bootable system diskette and restart. 2. Verify that the hard drive is partitioned and formatted. 3. Install the system files for the appropriate operating system, if necessary.
	Hard drive boot disabled in Computer Setup.	Run the Computer Setup (F10) Utility, and then enable the hard drive entry in the Storage>Boot Order list.
Workstation will not start.	Hard drive is damaged.	Observe the beeps and LEDs on the front of the workstation. Refer to POST error messages on page 140 .

Solving display problems

Table 6-6 Display problems

Problem	Cause	Solution
Blank screen (no video).	The cable connections are not correct.	Verify the cable connections from the monitor to the workstation and to a working electrical outlet.
	The monitor is off.	Switch the monitor on (LED is on). You might need to refer to the monitor manual for an explanation of the LED signals.

Table 6-6 Display problems (continued)

Problem	Cause	Solution
	Screen blanking utility installed or energy saver features enabled.	Press any key or press the mouse button, and, if set, enter your password.
	System ROM is bad; system is running in FailSafe Boot Block mode (indicated by 8 beeps).	Reflash the ROM using a SoftPaq.
	Fixed-sync monitor does not sync at the resolution specified.	Be sure that the monitor can accept the same horizontal scan rate as the resolution specified.
	Computer is in Hibernate mode.	Press the power button to resume from Hibernate mode.
	Workstation monitor settings are not compatible with the monitor.	<ol style="list-style-type: none"> 1. When you see Press F8 in the bottom-right corner of the screen, restart the workstation and press F8 during startup. 2. Using the keyboard arrow keys, select Enable VGA Mode and then press Enter. 3. In Windows Control Panel, double-click the Display icon and then select the Settings tab. 4. Use the sliding control to reset the resolution.
The display works properly during the POST but goes blank when the operating system starts.	The display settings in the operating system are incompatible with your graphics card and monitor.	<ol style="list-style-type: none"> 1. Restart your workstation in VGA mode. 2. After the operating system starts, change the display settings to match those supported by your graphics card and monitor. 3. Refer to your operating system and graphics card documentation for information about changing display settings.
Power LED flashes red 6 times (once every second), followed by a 2-second pause, and then the workstation beeps 6 times.	Pre-video graphics error.	<p>For systems with a graphics card:</p> <ol style="list-style-type: none"> 1. Reseat the graphics card. 2. Replace the graphics card. 3. Replace the system board.
Monitor does not function properly when used with Energy Saver features.	Monitor without Energy Saver capabilities is being used with Energy Saver features enabled.	Disable monitor Energy Saver feature.
Dim characters	The brightness and contrast controls are not set properly.	Adjust the monitor brightness and contrast controls.
	Cables are not properly connected.	Verify that the graphics cable is securely connected to the graphics card and the monitor.
Blurry video or requested resolution cannot be set.	If the graphics controller was upgraded, the correct video drivers might not be loaded.	Install the video drivers included in the upgrade kit.
	Monitor is not capable of displaying requested resolution.	Change requested resolution.

Table 6-6 Display problems (continued)

Problem	Cause	Solution
The picture is broken up, rolls, jitters, or flashes.	The monitor connections might be incomplete, or the monitor might be incorrectly adjusted.	<ol style="list-style-type: none"> 1. Be sure the monitor cable is securely connected to the workstation. 2. In a two-monitor system, or if another monitor is in close proximity, ensure that the monitors are not interfering with each other's electromagnetic field by moving them apart. 3. Fluorescent lights or fans might be too close to the monitor.
	Monitor must be degaussed.	Degauss the monitor.
Vibrating or rattling noise coming from inside a CRT monitor when powered on.	Monitor degaussing coil has been activated.	None. It is normal for the degaussing coil to be activated when the monitor is powered on.
Clicking noise coming from inside a CRT monitor.	Electronic relays have been activated inside the monitor.	None. It is normal for some monitors to make a clicking noise when turned on and off, when going in and out of Standby mode, and when changing resolutions.
High pitched noise coming from inside a flat-panel monitor.	Brightness and contrast settings are too high.	Lower brightness and contrast settings.
Fuzzy focus; streaking, ghosting, or shadowing effects; horizontal scrolling lines; faint vertical bars; or unable to center the picture on the screen (flat-panel monitors using an analog VGA input connection only.)	Flat-panel monitor's internal digital conversion circuits might be unable to correctly interpret the output synchronization of the graphics card.	<ol style="list-style-type: none"> 1. Select the monitor's Auto-Adjustment option in the monitor's onscreen display menu. 2. Manually synchronize the Clock and Clock Phase onscreen display functions. Download SoftPaq SP20930 or SP22333 (depending on the monitor) to assist with the synchronization).
Certain typed symbols do not appear correctly.	The font you are using does not support that particular symbol.	Use the Character Map to locate and select the appropriate symbol. Select Start>All Programs>Accessories>System Tools>Character Map . You can copy the symbol from the Character Map into a document.

Solving audio problems

Table 6-7 Audio problems

Problem	Cause	Solution
Sound does not come out of the speaker or headphones.	Software volume control is turned down.	Double-click the Speaker icon on the taskbar and use the volume slider to adjust the volume.
	The external speakers are not turned on.	Turn on the external speakers.
	External speakers plugged into the wrong audio jack.	See your sound card documentation for proper speaker connection.
	Audio cable not connected.	Connect audio cable between CD or DVD-ROM drive and the system board.

Table 6-7 Audio problems (continued)

Problem	Cause	Solution
	Digital CD audio is not enabled.	Enable digital CD audio: <ol style="list-style-type: none"> 1. From the Control Panel, select System. 2. On the Hardware tab, select the Device Manager button. 3. Right-click the CD/DVD device and select Properties. 4. On the Properties tab, ensure that Enable digital CD audio for this CD-ROM device is selected.
	Headphones or devices connected to the line-out connector have muted the internal speaker.	Turn on and use headphones or external speakers, if connected, or disconnect headphones or external speakers.
	Volume is muted.	<ol style="list-style-type: none"> 1. From the Control Panel, select Sound, Speech and Audio Devices, and then select Sounds and Audio Devices. 2. Deselect the Mute checkbox.
	Computer is in Standby mode.	Press the power button to resume from Standby mode.
Noise or no sound comes out of the speakers or headphones.		<ol style="list-style-type: none"> 1. If using digital speakers that have a stereo jack and you want the system to auto switch to digital, use a stereo-to-mono adapter to properly engage the auto sense feature, or use the multimedia device properties to manually switch the audio signal from analog to digital. 2. If the headphones have a mono jack, use the multimedia device properties to switch the system to analog out.
<p>NOTE: If you set digital as the Output Mode, the internal speaker and external analog speakers no longer output audio until you switch back to an auto sense or analog mode.</p> <p>If you set analog as the Output Mode, external digital speakers do not function until you change the output mode back to an auto-sense or digital mode.</p>		
Sound occurs intermittently.	Processor resources are being used by other open applications.	Shut down all open processor-intensive applications.
Workstation appears to be locked up while recording audio.	The hard disk might be full.	<ol style="list-style-type: none"> 1. Before recording, be sure there is enough free space on the hard disk. 2. Try recording the audio file in a compressed format.

Solving printer problems

Table 6-8 Printer problems

Problem	Cause	Solution
Printer does not print.	Printer is not turned on and online.	Turn the printer on and be sure it is online.

Table 6-8 Printer problems (continued)

Problem	Cause	Solution
	The correct printer driver for the application is not installed.	<ol style="list-style-type: none"> 1. Install the correct printer driver for the application. 2. Try printing using the MS-DOS command: DIR C:\> [printer port] where <i>printer port</i> is the address of the printer used. If the printer works, reload the printer driver.
	If you are on a network, you might not have made a connection to the printer.	Make the proper network connection to the printer.
	Printer might have failed.	Run printer self-test.
Printer does not turn on.	The cables might not be connected properly.	Reconnect all cables.
Printer prints garbled information.	The correct printer driver is not installed.	Install the correct printer driver for the application.
	The cables might not be connected properly.	Reconnect all cables.
	Printer memory might be overloaded.	Reset the printer by turning it off for one minute, then turn it back on.
Printer is offline.	The printer might be out of paper.	<ol style="list-style-type: none"> 1. Verify that the paper tray and refill it if it is empty. 2. Select Online.

Solving keyboard and mouse problems

Table 6-9 Keyboard and mouse problems

Problem	Cause	Solution
Keyboard commands and typing are not recognized by the workstation.	Keyboard connector is not properly connected.	<ol style="list-style-type: none"> 1. Power off the workstation. 2. Reconnect the keyboard to the back of the workstation and restart the workstation.
	Program in use has stopped responding to commands.	Shut down the workstation using the mouse, and then restart the workstation.
	Keyboard needs repairs.	Replace the keyboard.
	Keyboard key is stuck down.	Remove any debris from the keyboard.
	Workstation is in Hibernate mode.	Press the power button to resume from Hibernate mode.
Cursor will not move using the arrow keys on the keypad.	The Num Lock key might be on.	Press the Num Lock key. The Num Lock light should not be on if you want to use the arrow keys. The Num Lock key can be disabled or enabled in the Computer Setup (F10) Utility.
Mouse does not respond to movement or is too slow.	Mouse connector is not properly plugged into the back of the workstation.	<ol style="list-style-type: none"> 1. Shut down the workstation using the keyboard. 2. Plug the mouse connector into the PS/2 mouse connector slot in the workstation, and then restart the workstation.
	Program in use has stopped responding to commands.	Shut down the workstation using the keyboard and then restart the workstation.

Table 6-9 Keyboard and mouse problems (continued)

Problem	Cause	Solution
	Mouse needs repairs.	Replace the mouse.
	Workstation is in Standby mode.	Press the power button to resume from Standby mode.
Mouse only moved vertically or horizontally, or the movement is jerky.	Mouse rollerball is dirty.	Remove the rollerball cover from the bottom of the mouse, clean it, and then replace cover.

Solving front panel component problems

If you are experiencing problems with one of the front panel ports, you might be able to try your device in the corresponding port on the back side of the computer. If this does not fix the problem, or you must use the front panel ports, continue troubleshooting.

Some problems in this section are also discussed in other troubleshooting suggestions in this chapter.

Table 6-10 Front panel component problems

Problem	Cause	Solution
A USB device, headphone, or microphone is not recognized by the workstation.	The device is not properly connected.	<ol style="list-style-type: none"> 1. Power off the workstation. 2. Reconnect the device to the front of the workstation and restart the workstation.
	The device does not have power.	If the USB device requires AC power, be sure one end is connected to the device and one end is connected to a live outlet.
	The correct device driver is not installed.	<ol style="list-style-type: none"> 1. Install the correct driver for the device. 2. You might need to reboot the workstation.
	The cable from the device to the computer does not work.	<ol style="list-style-type: none"> 1. If possible, replace the cable. 2. Restart the workstation.
	The device is not working.	<ol style="list-style-type: none"> 1. Replace the device. 2. Restart the workstation.
A USB, audio, or IEEE-1394 device is not working.	The internal cables might not be connected to the system board or the PCI card.	<ol style="list-style-type: none"> 1. Power off the workstation. 2. Connect the cables correctly.
A device in the IEEE-1394 port is not responsive.	Cables of the external device are loose, or power cables are unplugged.	Be sure that all cables are properly and securely connected.
	The power switch on the device is not turned on.	Power off the workstation, power on the external device, then power on the workstation to integrate the device with the workstation system.
The IEEE-1394 port is not active.	The port is not there because it was not purchased with the system.	You can buy an IEEE 1394 PCI adapter card. Contact an HP seller.

Solving hardware installation problems

You might need to reconfigure the workstation when you add or remove hardware, such as an additional diskette drive. If you install a Plug and Play (PnP) device, the operating system automatically recognizes the device and configures the workstation. If you install a nonPnP device, you must reconfigure the workstation after completing installation of the new hardware.

Table 6-11 Hardware installation problems

Problem	Cause	Solution
A new device is not recognized as part of the system.	Device is not seated or connected properly.	Be sure that the device is properly and securely connected and that pins in the connector are not bent.
	Cables of new external device are loose, or power cables are unplugged.	Be sure that all cables are properly and securely connected and that pins in the cable or connector are not bent.
	Power switch of new external device is not turned on.	Power off the workstation, power on the external device, and then power on the workstation to integrate the device into the workstation system.
	When the system advises you about changes to the configuration, you do not accept them.	Reboot the workstation and follow the instructions for accepting the changes.
Workstation does not start.	A PnP board might not automatically configure when added if the default configuration conflicts with other devices.	Use Windows XP Device Manager to deselect the automatic settings for the board and choose a basic configuration that does not cause a resource conflict. You can also use the Computer Setup (F10) Utility to reconfigure or disable devices to resolve the resource conflict.
	Device hardware is not properly jumpered or otherwise configured.	Read the device-specific configuration information and check for incorrect settings or conflicts with other devices already installed in the system.
	Wrong memory modules were used in the upgrade, or memory modules were installed in the wrong location.	<ol style="list-style-type: none"> 1. Review the documentation that came with the system to determine if you are using the correct memory modules and to verify the proper installation. 2. Observe the beeps and LEDs on the front of the workstation. Refer to POST error messages on page 140 to determine possible causes.
	PCI Express power cable might be plugged into the wrong connector on the system board.	Connect the auxiliary PCI Express power cable to the PCI Express card.
Power LED flashes red 5 times (once every second), followed by a 2-second pause, and then the workstation beeps 5 times.	Memory is installed incorrectly or is bad.	<ol style="list-style-type: none"> 1. Reseat DIMMs. 2. Replace DIMMs one at a time to isolate the faulty module. 3. Replace third-party memory with HP memory. 4. Replace the system board.
Power LED flashes red 6 times (once every second), followed by a 2-second pause, and then the workstation beeps 6 times.	Video card is not seated properly or is bad, or system board is bad.	<p>For systems with a graphics card:</p> <ol style="list-style-type: none"> 1. Reseat the graphics card. 2. Replace the graphics card. 3. Replace the system board.

Solving network problems

The following table provides fixes for common network problems.

Table 6-12 Network problems

Problem	Cause	Solution
Wake-on-LAN feature is not functioning.	Wake-on-LAN is not enabled.	Use the network control application to enable Wake-on-LAN.
Network driver does not detect network controller.	Network controller is disabled.	Run the Computer Setup (F10) Utility to enable network controller.
	Incorrect network driver.	Review the network controller documentation to verify the correct driver, or obtain the latest driver from the manufacturer's website.
Network status link light does not illuminate or never flashes.	No active network is detected.	Verify cabling and network equipment for proper connection.
The network status light does not flash when there is network activity.	Network controller is not set up properly.	Use the network control application to verify that the device is working properly.
	Network driver is not properly loaded.	Reinstall network drivers.
	System cannot auto sense the network.	Disable auto sensing capabilities and force the system into the correct operating mode.
Diagnostics reports a failure.	The cable is not securely connected.	Be sure that both ends of the data cable are securely connected.
	The cable is attached to the incorrect connector.	Be sure that the cable is attached to the correct connector.
	There is a problem with the cable or a device at the other end of the cable.	Be sure that the cable and device at the other end are operating correctly.
	Network controller interrupt is shared with an expansion board.	Under the Computer Setup (F10) Utility Advanced menu, change the resource settings for the board.
Diagnostics passes, but the workstation does not communicate with the network.	The network controller is defective.	Replace the NIC.
	Network drivers are not loaded, or driver parameters do not match current configuration.	<ol style="list-style-type: none"> 1. Be sure the network drivers are loaded and that the driver parameters match the configuration of the network controller. 2. Be sure the correct network client and protocol is installed.
	The network controller is not configured for this workstation.	Double-click the Network icon in the Control Panel and configure the network controller.
Network controller stopped working when an expansion board was added to the workstation.	Network controller interrupt is shared with an expansion board.	Under the Computer Setup (F10) Utility Advanced menu, change the resource settings for the board.
	The network controller requires drivers.	Verify that the drivers were not accidentally deleted when the drivers for the expansion board were installed.
	The expansion board installed is a network card and conflicts with the embedded network card.	Under the Computer Setup (F10) Advanced menu, change the resource settings for the board.

Table 6-12 Network problems (continued)

Problem	Cause	Solution
Network controller stops working without apparent cause.	The files containing the network drivers are corrupted.	Reinstall the network drivers using the <i>Restore Plus!</i> CD.
	The cable is not securely connected.	Be sure that both ends of the cable are securely attached to the correct devices.
	The network controller is defective.	Replace the NIC.
New network card does not boot.	New network card might be defective or might not meet industry-standard specifications.	Install a working, industry-standard NIC, or change the boot sequence to boot from another source.
Cannot connect to network server when attempting remote system installation.	The network controller is not configured properly.	Verify network connectivity, that a DHCP server is present, and that the Remote System Installation Server contains the NIC drivers for your NIC.
Computer Setup (F10) Utility reports unprogrammed EEPROM.	Unprogrammed EEPROM.	Flash the ROM.

Solving memory problems

△ **CAUTION:** For those systems that support ECC memory, HP does not support mixing ECC and nonECC memory. The operating system does not boot with mixed-ECC memory.

Table 6-13 Memory problems

Problem	Cause	Solution
System does not boot (or does not function properly) after installing additional memory modules.	A memory module is not the correct type or speed or the new memory module is not seated properly.	Replace module with the correct, industry-standard device for the workstation.
		On some models, ECC and nonECC memory modules cannot be mixed.
Out of memory error.	Memory configuration might not be set up correctly.	Use the Device Manager to verify memory configuration.
	You have run out of memory to run the application.	Review the application documentation to determine the memory requirements.
Memory count during POST is wrong.	The memory modules might not be installed correctly.	Verify that the memory modules have been installed correctly and that proper modules are used.
Insufficient memory error during operation.	Too many Terminate and Stay Resident (TSR) programs are installed.	Delete any TSRs that you do not need.
	You have run out of memory for the application.	Verify the memory requirements for the application or add more memory to the workstation.
Power LED flashes red 5 times (once every second), followed by a 2-second pause, and then the workstation beeps 5 times.	Memory is installed incorrectly or is bad.	<ol style="list-style-type: none"> 1. Reseat DIMMs. 2. Replace DIMMs one at a time to isolate the faulty module. 3. Replace third-party memory with HP memory. 4. Replace the system board.

Solving processor problems

Table 6-14 Processor problems

Problem	Cause	Solution
Poor performance is experienced.	Processor is hot.	<ol style="list-style-type: none"> 1. Be sure the airflow to the workstation is not blocked. 2. Be sure the fans are connected and working properly (some fans only operate when needed). 3. Be sure the processor heatsink is installed properly.
Power LED is red and stays on.	Processor is not seated properly or not installed.	<ol style="list-style-type: none"> 1. Verify that the processor is present. 2. Reseat the processor.

Solving DVD problems

Table 6-15 DVD problems

Problem	Cause	Solution
System does not boot from DVD drive.	The DVD boot is not enabled through the Computer Setup (F10) Utility.	Run the Computer Setup (F10) Utility and enable booting to removable media and verify boot order settings.
	Nonbootable CD in drive.	Try a bootable CD in the drive.
DVD devices are not detected or the driver is not loaded.	Drive is not connected properly or not properly configured.	<ol style="list-style-type: none"> 1. Reconnect power and data cables to the drive. 2. Install correct device driver.
Movie does not play in the DVD drive.	Movie might be regionalized for a different country.	See the documentation included with the DVD drive.
	Decoder software is not installed.	Install decoder software.
Cannot eject CD (tray-load unit).	Disc not properly seated in the drive.	<ol style="list-style-type: none"> 1. Power off the workstation and insert a thin metal rod (such as a paper clip) into the emergency eject hole and push firmly. 2. Slowly pull the tray out from the drive until the tray is fully extended, and then remove the disc.
CD-RW or DVD-R/RW drive cannot read a disc or takes too long to start.	CD has been inserted upside down.	Reinsert the CD with the label facing up.
	The DVD-ROM drive takes longer to start because it has to determine the type of media played, such as audio or video.	Wait at least 30 seconds to let the DVD-ROM drive determine the type of media being played. If the disc still does not start, read the other solutions listed for this topic.
	DVD disc is dirty.	Clean DVD with a CD cleaning kit.

Table 6-15 DVD problems (continued)

Problem	Cause	Solution
	Windows does not detect the DVD-ROM drive.	<ol style="list-style-type: none"> 1. Use Device Manager to remove or uninstall the device. 2. Restart the workstation and allow Windows to detect the device.
Recording audio CDs is difficult or impossible.	Wrong or poor-quality media type.	<ol style="list-style-type: none"> 1. Use a slower recording speed. 2. Verify that you are using the correct media for the drive. 3. Try a different brand of media. Quality varies widely between manufacturers.

Solving Internet access problems

Table 6-16 Internet access problems

Problem	Cause	Solution
Unable to connect to the Internet.	Internet Service Provider (ISP) account is not set up properly.	Verify Internet settings or contact the ISP for assistance.
	Modem is not set up properly.	Reconnect the modem. Verify the connections are correct using the quick setup documentation.
	Web browser is not set up properly.	Verify that the Web browser is installed and set up to work with your ISP.
	Cable/ DSL modem is not plugged in.	Plug in cable/DSL modem. When properly connected, the power LED on the front of the cable/DSL modem should be illuminated.
	Cable/DSL service is not available or has been interrupted because of bad weather.	Try connecting to the Internet at a later time, or contact your ISP. If the cable/DSL service is connected, the cable LED light on the front of the cable/DSL modem is on.
	The CAT5 10/100/1000 cable is disconnected.	Connect the CAT5 10/100/1000 cable between the cable modem and the workstations's RJ-45 connector. (If the connection is good, the "PC" LED on the front of the cable/DSL modem will be on.)
	IP address is not configured properly.	Contact the ISP for the correct IP address.
	Cookies are corrupted.	<ol style="list-style-type: none"> 1. Select Start>Control Panel. 2. Double-click Internet Options. 3. On the General tab, select the Delete Cookies button.

Table 6-16 Internet access problems (continued)

Problem	Cause	Solution
Cannot automatically launch Internet programs.	You must log on to the ISP before some programs will start.	Log on to the ISP and launch the desired program.
Internet takes too long to download websites.	Modem is not set up properly.	<ol style="list-style-type: none">1. Select Start>Control Panel.2. Double-click System, and then select the Hardware tab.3. In the Device Manager area, select the Device Manager button.4. Double-click Ports (COM & LPT).5. Right-click the COM port that your modem uses, and then select Properties.6. Under Device status, verify that the modem is working properly.7. Under Device usage, verify that the modem is enabled.8. If there are further problems, select the Troubleshoot button and follow the onscreen instructions.

Troubleshooting checklist

Before running diagnostic utilities, use the following checklist to find possible solutions for workstation or software problems.

- Is the workstation and monitor connected to a working electrical outlet?
- Is the workstation powered on?
- Is the green power light illuminated?
- Is the monitor on?
- Is the green monitor light illuminated?
- If the monitor is dim, adjust the monitor brightness and contrast controls.
- Press and hold any key. If the system beeps, the keyboard is operating correctly.
- Check cables for loose or improper connections.
- After installing a non-plug and play (PnP) expansion board or other option (such as a diskette drive), reconfigure the workstation.
- Are all necessary device drivers installed?
- Have all printer drivers been installed for each application?
- Have you removed diskettes, optical disks, and USB drive keys from the drives before powering on the workstation?
- Are you running the latest version of BIOS, drivers, and software?

LED color definitions

The following table describes what each LED light on your workstation front panel signifies.

Table 6-17 LED color definitions

LED state	LED color	System status
Solid	Green	System is on
Flashing	Green	System is in Standby
Solid or flashing	Red	System has experienced an error. See Diagnostic LED codes on page 111
None	No light	System is in Hibernate, or it is off

Self-troubleshooting with HP Vision Field Diagnostics

Hewlett-Packard Vision Field Diagnostics is a diagnostic tool that can be used by the end user or technical support personnel to view information about the hardware configuration of the computer and perform hardware troubleshooting on HP Desktop and Workstation systems. This diagnostic tool should be used to help determine hardware failures. Accessible by either CD or USB key, these diagnostics run outside the operating system and so make it easy to isolate potential issues that may be operating system related versus hardware.

HP Vision Field Diagnostics benefits are:

- Capture complete system configuration information that can be shared as an HTML file, including:
 - System serial number
 - System product number
 - System BIOS revision
 - Memory size and configuration
 - Processor information
 - Storage device information and configuration
 - Graphics / audio / communications information and configuration
 - And more...
- Comprehensive list of diagnostic test available with new added features:
 - Highly configurable testing options: quick / complete / custom / interactive / non-interactive
 - Specific failing memory DIMM identification
 - Tests video card memory
 - Launches DST Smart tests for both SATA and SAS drives
 - Many other tests and diagnostics
- Diagnostic Failure Code Output – A unique warranty code is generated for each failure which can be used to validate diagnostic use for a specific system
- Easy to use - uses similar user interface as previous field diagnostics, HP Insight Diagnostics

- True End2End diagnostics – same diagnostics modules used in factory
- Easy to obtain
 - Download from Web
 - USB key bootable or CD bootable
 - Included with restore media

It is expected that these Vision diagnostics will be run on supported products when attempting to troubleshoot system issues.

Overview

The HP Vision Field Diagnostics utility allows you to view information about the hardware configuration of the workstation and perform hardware diagnostic tests on the subsystems of the workstation. The utility simplifies the process of effectively identifying, diagnosing, and isolating hardware issues.

The Survey tab is displayed when you invoke HP Vision Field Diagnostics. This tab shows the current configuration of the workstation. From the Survey tab, there is access to several categories of information about the workstation. Other tabs provide additional information, including diagnostic test options and test results. The information in each screen of the utility can be saved as an html file and stored on a diskette or USB flash drive.

Use HP Vision Field Diagnostics to determine if all the devices installed on the workstation are recognized by the system and functioning properly. Running tests is optional but recommended after installing or connecting a new device.

You should run tests, save the test results, and print them so that you have printed reports available before placing a call to the Customer Support Center.



NOTE: Third-party devices may not be detected by HP Vision Field Diagnostics.

Downloading and accessing HP Vision Field Diagnostics

Follow these steps to download the HP Vision Field Diagnostics utility from the HP Web site to a DVD or USB, and then use it to perform diagnostics on the workstation:

1. Go to <http://www.hp.com>.
2. Select the **Support & Drivers** link.
3. Select the **Download driver and software** radio button.
4. Enter your product number in the text box, and then press **Enter**.
5. Select your operating system.
6. Select the **Diagnostic** link.
7. Locate **HP Vision Field Diagnostics** and select **Download**.
8. After the *.iso* file is downloaded, use CD-ROM burning software to copy the *.iso* file to an optical medium or USB flash drive.
9. When the CD or USB flash drive has the utility installed, insert the CD or USB flash drive into the workstation (while it is on).
10. Shut down the operating system and turn off the workstation.
11. Turn on the workstation. The system will boot into HP Vision Field Diagnostics.



NOTE: If the system does not boot to the CD in the optical drive or to the USB flash drive, you may need to change the boot order. You may use the Computer Setup (F10) utility to change the boot order, or you may press F9 to select the appropriate boot device.

12. At the boot menu, select either the **HP Vision Field Diagnostics** utility to test the various hardware components in the computer or the **HP Memory Test** utility to test memory only.



NOTE: The HP Memory Test is a comprehensive memory diagnostic utility that is run as a stand-alone application, outside of HP Vision Field Diagnostics.

If the workstation is booted from a CD, a separate boot CD will be required to use the memory diagnostic. Hence, HP recommends that a USB key be used to boot the diagnostic utilities. It is faster than using a CD, and it accommodates both Memory and Vision diagnostics.

13. If running HP Vision Field Diagnostics, select the appropriate language and click **Continue**.
14. In the End User License Agreement page, select **Agree** if you agree with the terms. The HP Vision Field Diagnostics utility launches with the Survey tab displayed

Accessing HP Vision Field Diagnostics on the workstation

The following procedures describe how to access the HP Vision Field Diagnostics utilities that are included in the workstation software.

Creating and using a bootable USB key

This section describes how to use a USB key to access the HP Vision Field Diagnostics.

 **NOTE:** Using a USB key is the most convenient method to access the HP Vision Field Diagnostics.

1. In the C:\VisionDiagnostics\ directory, double-click on VisionDiagUSB.exe. A setup menu appears.
2. Follow the setup prompts to create a bootable ISO image of the diagnostic utilities on a USB key.
3. Turn off the workstation and restart it with the USB key installed. The workstation will boot to the USB key and initiate the HP Vision Field Diagnostics utility.
4. Follow the HP Vision Field Diagnostic prompts to troubleshoot the workstation.

Creating and using a bootable DVD

This section describes how to use a DVD to access the HP Vision Field Diagnostics.

1. In the C:\VisionDiagnostics\ directory, double-click on the VisionDiagISO.exe file. A setup menu appears.
2. Follow the setup prompts to create a bootable ISO image of the diagnostic utilities on a DVD.
3. Enable the workstation to boot from DVD.
4. Turn off the workstation and restart it with the DVD installed in the optical drive. The workstation will boot to the DVD and initiate the HP Vision Field Diagnostics utility.
5. Follow the HP Vision Field Diagnostic prompts to troubleshoot the workstation.

Using the HP Memory Test utility

This section describes how to access the HP Memory Test utility.

 **NOTE:** The HP Memory Test is a comprehensive memory diagnostic utility that is run as a stand-alone application, outside of HP Vision Field Diagnostics.

If the workstation is booted from a CD, a separate boot CD will be required to use the memory diagnostic. Hence, HP recommends that a USB key be used to boot the diagnostic utilities. It is faster than using a CD, and it accommodates both Memory and Vision diagnostics.

1. In the C:\VisionDiagnostics\ directory, double-click on the MemoryDiagISO.exe file. A setup menu appears.
2. Follow the setup prompts to create a bootable ISO image of the memory diagnostic utility on a DVD.
3. Turn off the workstation and restart it with the DVD installed in the optical drive. The workstation will boot to the DVD and initiate the memory diagnostic utility.
4. Follow the diagnostic prompts to troubleshoot workstation memory.

User interface

The HP Vision Field Diagnostics application provides six major functions, accessible through Tabs. These functions are:

- **Survey** — Your current system hardware information.
- **Test** — List all diagnostics available for your system. Tests are started there.
- **Status** — This screen shows progress and status of currently running diagnostics.
- **History** — All past diagnostics runs and status are listed there.
- **Errors** — All past diagnostics failures are listed there.
- **Help** — User help about HP Vision Diagnostics.

There are also some common operations that are part of the utility. They include:

- **Exit Diagnostics** button — This button will close HP Vision Diagnostic application and reboot your system. Any running test will be aborted.
- **Reload** button — If available, this button will rescan your system hardware and reload the diagnostics without the need to restart your entire system.
- **Save** button — If available, save your system survey, test history or error data as an HTML file to a floppy disk or a USB key drive.

Survey tab

The Survey tab shows your system hardware information, organized into eleven Categories (for example "Processors") and device instances (for example "Processor 1").

The amount of information displayed can be controlled by selecting a combination of View Level and Category.

The **View Levels** include:

- **Overview** — shows high level summary of the system hardware. This is the default view level.
- **Summary** — gives limited configuration data for each specific Category.
- **Advanced** — offers more technical and low-level data for the computer-savvy user.

The **Categories Levels** include:

- **All** — Shows all Categories.
- **Architecture** — Shows system architecture information such as high level PCI devices, low level SMBIOS, CMOS and PCI configuration space data.
- **Audio** — Shows all embedded and add-on audio devices.
- **Asset Control** — Shows asset control related information such as product name, serial number, asset tag, and universal unique ID information.
- **Communication** — Shows communication devices such as serial, parallel, USB, network, Firewire, modem, and Bluetooth ports and devices.
- **Graphics** — Shows all embedded and add-on video cards.
- **Input Devices** — Shows user input devices such as all connected mice and keyboards.
- **Memory** — Shows system memory information.

- **Miscellaneous** — List any devices or data that doesn't belong to any other Category.
- **Processors** - Shows system processors.
- **Storage** — Shows mass storage devices such as floppy drives, optical drives, SATA, SAS hard disk drives and controllers, as well as any RAID arrays.
- **System** — Shows information about motherboard devices such as fans and cables.

Test tab

The Test tab lists all available diagnostics. The lists have been tailored according to your system configuration. Individual test may be selected or unselected. The following Test Modes exist:

- **Quick** — This test selection was picked to perform quickly while covering your entire hardware. Test parameters cannot be modified.
- **Complete** — This test selection offers all available tests and may take a long time to complete. Test parameters cannot be modified.
- **Custom** — Like Complete this test selection offers all available tests. The test parameters may be modified to fit specific needs. For advanced users only!

By default, the three test modes do not display prompts and require no interaction. If errors are found, they are displayed when testing is complete.

However, for each test type, you may also optionally add interactive tests by clicking the **Include interactive tests** box under Test mode. Selecting interactive tests provides the maximum control over the testing process. The diagnostic software will prompt you for input during tests.

 **NOTE:** Memory can not be tested from within the HP Vision Field Diagnostics application. To test the memory in your workstation, exit HP Vision Field Diagnostic, boot to either the CD or USB flash drive and select **HP Memory Test** from the boot menu.

The **Duration of Test** options control the duration of the test sequence. The following options are available:

- **Number of loops** — A test selection will run once by default. Enter a positive number to make a test selection run many times.
- **Total test time (hours:minutes)** — Alternatively, the test selection can be set to run for a specified amount of time. This does not guarantee that all tests will run if the entered time is less than the necessary time to run all the tests
- **Stop at first error**— Check this option to stop test execution as soon as one error is encountered.

The following **Test Controls** exist:

- **Select All, Unselect All** button — This button toggles to select or unselect all the tests from the test selection tree.
- **Expand, Collapse** button — This button toggles to expand or collapse the test selection tree.
- **Start Test** button — Click this button to start executing all selected tests. HP Vision Field Diagnostics will automatically switch to the Status tab in order to keep track of the test execution and status.

 **WARNING!** Once started, do not reboot or power off your computer until all the tests have been completed.

To begin testing:

1. Select the Test tab.
2. Select the type of tests you want to run: **Quick**, **Complete**, or **Custom**.
3. Include optional interactive tests by selecting **Include interactive tests**.
4. Choose how you want the test to be executed, either **Number of Loops** or **Total Test Time**. When choosing to run the test over a specified number of loops, enter the number of loops to perform. If you want the diagnostic test for a specified time period, enter the amount of time in minutes.

5. Click the **Start Test** button to start the testing. The Status tab, which allows you to monitor the progress of the tests, is automatically displayed during the testing process. When the tests are complete, the Status tab shows whether the devices passed or failed.
6. If errors are found, go to the Errors tab to display detailed information and recommended actions.

Status tab

The Status tab shows the overall progress and status of the test scenario as well as the progress and status of each test. The color coded status are black, blue, green, red, and orange.

The Status tab colors are:

- **Waiting** (black) — when no test is running
- **Running** (blue) — when at least one test is currently running
- **Passed** (green) — when all tests have run successfully, meaning that no hardware error or defect have been detected
- **Failed** (red) — when three tests have detected at least one error with your system
- **Canceled** (orange) — when the test scenario has been explicitly canceled, in which case no pass or fail conclusion can be drawn

The available data is:

- **Current Loop** — Shows the current execution loop out of total number of loops specified in the Test panel.
- **Test Time** — Shows the total time elapsed since the beginning of the test execution.
- **Test Complete** — Shows the number of tests successfully completed out of the total number of test to execute.
- **Cancel** button — Push the Cancel button to immediately terminate all currently running tests.

History tab

The History tab shows the history of the past test executions.

The History Log displays all tests that have been executed, the number of times of execution, the number of times failed, the date each test was executed, and the time it took to complete each test. The **Clear History** button will clear the contents of the History Log.

The contents of the History Log may be saved as a HTML file to either floppy or USB flash drive by clicking the **Save** button.

Errors tab

The Errors tab displays detailed information about any errors found, as well as any recommended actions.

The Error Log displays the tests for devices that have failed during the diagnostic testing and includes the following columns of information.

- The Device section displays the device tested.
- The Test section displays the type of test run.
- The Times Failed is the number of times the device has failed a test.
- The Defect Code provides a numerical code for the failure. The error codes are defined in the Help tab.
- The Description section describes the error that the diagnostic test found.
- The Reason section describes the likely cause of the error.

- The Recommended Repair will give a recommended action that should be performed to resolve the failed hardware.
- The Warranty ID is a unique error code associated with the specific error on your computer. When contacting the HP Support Center for assistance with a hardware failure, please be prepared to provide the Warranty ID.
- The Clear Errors button will clear the contents of the Error Log.

The contents of the Error Log may be saved as a HTML file to either floppy or USB flash drive by clicking the **Save** button.

Help tab

The Help tab contains a Vision Help section, and a Test Components section. This tab includes search and index features. You may also review the HP End User License Agreement (EULA), as well as the HP Vision Field Diagnostic application version information on this tab.

The various sections located here are:

- The Vision Help section contains information on the major functions of HP Vision Field Diagnostics.
- The Test components section provides a description of each test, as well as the parameters that may be adjusted when running in Custom test mode.
- The Defect codes section contains information on the numerical error code that may appear in the Errors tab.
- The Memory test tab section provides information on the HP Memory Test application that may be launched from the boot menu.
- The HP Support section provides information on obtaining technical support from HP.

Saving and printing information in HP Vision Field Diagnostics

You can save the information displayed in the HP Vision Field Diagnostics Survey, History and Errors tabs to a diskette or a USB flash drive. You can not save to the hard drive. The system will automatically create an html file that has the same appearance as the information displayed on the screen.

1. Insert a diskette or USB flash drive if running HP Vision Field Diagnostics from CD.
2. Click **Save** in the bottom on any of the Survey, History or Errors tabs. All three log files will be saved regardless of from which tab the Save button was clicked.
3. Select the drive onto which you will save the log files and click the **Save** button. Three html files will be saved to the inserted diskette or USB flash drive.

 **NOTE:** Do not remove the diskette or USB key until you see a message indicating that the html files have been written to the media.

4. Print the desired information from the storage device used to save it.

 **NOTE:** To exit HP Vision Field Diagnostics, click the **Exit Diagnostics** button at the bottom of the screen. Be sure to remove the USB flash drive or CD from the optical drive.

POST error messages

Power On Self Test (POST) is a program run at startup that initializes and runs tests on installed hardware. An audible and/or visual message appears if the POST encounters a problem. POST checks the following items to ensure that the workstation system is functioning properly:

 **NOTE:** If the power-on password is set, a key icon appears on the screen while POST is running. You must enter the password before continuing.

Table 6-18 POST error messages

Screen message	Probable cause	Recommended action
101—Option ROM Error	System ROM checksum	Verify the correct ROM: <ol style="list-style-type: none">1. Flash the ROM, if needed.2. If an expansion card was recently added, remove it to find out if the problem remains.3. Clear CMOS. If the message disappears, there might be a problem with the expansion card4. Replace the system board.
102—System Board Failure	DMA, timers, and so on	<ol style="list-style-type: none">1. Clear CMOS.2. Remove expansion boards.3. Replace the system board.
103—System Board Failure	DMA, timers, and so on	<ol style="list-style-type: none">1. Clear CMOS.2. Remove expansion boards.3. Replace the system board.
110—Out of Memory for Option ROMs	Option ROM for a device was unable to run due to memory constraints.	Run the Computer Setup (F10) Utility to enable the ACPO/USB Buffers at Top of Memory under the Advanced>Power-On option.

Table 6-18 POST error messages (continued)

Screen message	Probable cause	Recommended action
162—System Options Not Set	Configuration incorrect. RTC battery might need replacement.	<ol style="list-style-type: none"> 1. Run Computer Setup (F10) Utility. 2. Set the date and time from the Control Panel or in the setup utility (depending on the operating system). 3. If the problem persists, replace the RTC battery.
163—Time and Date Not Set	<p>Invalid time or date in configuration memory.</p> <p>RTC battery might need replacement.</p> <p>CMOS jumper might not be properly installed.</p>	<ol style="list-style-type: none"> 1. Set the date and time from the Control Panel or in the Computer Setup (F10) Utility (depending on the operating system). 2. If the problem persists, replace the RTC battery.
164—Memory Size Error	Memory configuration is incorrect.	<ol style="list-style-type: none"> 1. Run the Computer Setup (F10) Utility or Windows utilities. 2. Verify that the memory modules (if any) are installed properly. 3. If third-party memory has been added, test using HP memory only. 4. Verify proper memory module type.
201—Memory Error	RAM failure.	<ol style="list-style-type: none"> 1. Run the Computer Setup (F10) utility or Windows utilities. 2. Be sure that memory and continuity modules are installed correctly. 3. Verify proper memory module type. 4. Remove and replace memory modules one at a time to isolate faulty modules. 5. Replace faulty memory modules. 6. If error persists after replacing memory modules, replace the system board.
202—Memory Type Mismatch	Memory modules do not match.	Replace memory modules with matched sets.
207—ECC Corrected Single Bit Errors in Memory Socket(s) y,y	Single-bit ECC error.	<ol style="list-style-type: none"> 1. Verify proper memory module type. 2. Insert the DIMM in another memory socket. 3. Replace memory module if problem persists.
212—Failed Processor	Processor has failed to initialize.	<ol style="list-style-type: none"> 1. Reseat the processor in its socket. 2. If the processor does not respond, replace it.
213—Incompatible memory Module in memory Socket(s) x,x	A memory module in memory socket identified in the error message is missing critical SPD information or is incompatible with the chipset.	<ol style="list-style-type: none"> 1. Verify proper memory module type. 2. Insert the DIMM in another memory socket. 3. Replace module with a DIM conforming to the SPD standard.
214—DIMM Configuration Warning	DIMMs not installed correctly (not paired correctly).	See the illustration on the side access panel for the correct memory configurations, and reseat the DIMMs accordingly.

Table 6-18 POST error messages (continued)

Screen message	Probable cause	Recommended action
215—Memory Mismatch Warning	There are one or more mismatched pairs of DIMMs between channel A and channel B. Some memory has been disabled. Install matching pairs or remove the mismatched DIMMs from channel B.	See the illustration on the side access panel for the correct memory configurations, and reseal the DIMMs accordingly.
216—Memory Size Exceeds Maximum Supported	The amount of memory installed exceeds that supported by the hardware.	<ol style="list-style-type: none"> 1. Verify how much memory your system supports. 2. Remove the excess memory.
219—ECC Memory Module Detected.	ECC modules not supported on this platform.	Remove the ECC module.
301—Keyboard Error	Keyboard failure.	<ol style="list-style-type: none"> 1. Reconnect the keyboard with the workstation powered off. 2. Check the connector for bent or missing pins. 3. Be sure that none of the keys are pressed. 4. Replace the keyboard.
303—Keyboard Controller Error	I/O board keyboard controller.	<ol style="list-style-type: none"> 1. Reconnect keyboard with workstation turned off. 2. Replace the system board.
304—Keyboard or System Unit Error	Keyboard failure.	<ol style="list-style-type: none"> 1. Reconnect the keyboard with workstation turned off. 2. Be sure that none of the keys are pressed. 3. Replace keyboard. 4. Replace system board.
411—Network Interface Card Interrupt Conflict	IRQ address conflicts with another device.	Reset the IRQ.
501—Display Adapter Failure	Graphics display controller.	<ol style="list-style-type: none"> 1. Reseat the graphics card (if applicable). 2. Clear CMOS. 3. Verify that the monitor is attached and turned on.
510—Splash Screen image corrupted	Splash Screen image has errors.	To restore the image, install the latest SoftPaq.
511—CPU, CPUA, or CPUB Fan not detected	Fan is not connected, or might have malfunctioned.	<ol style="list-style-type: none"> 1. Reseat the fan cable. 2. Reseat the fan. 3. Replace the fan.
512—Chassis, rear chassis, or front chassis fan not detected	Fan is not connected, might have malfunctioned.	<ol style="list-style-type: none"> 1. Reseat the chassis, rear chassis, or front chassis fan cable. 2. Reseat the chassis, rear chassis, or front chassis fan. 3. Replace the chassis, rear chassis, or front chassis fan.
514—CPU or Chassis Fan not detected	Processor fan is not connected or might have malfunctioned.	<ol style="list-style-type: none"> 1. Reseat the processor or chassis fan. 2. Replace the processor or chassis fan.

Table 6-18 POST error messages (continued)

Screen message	Probable cause	Recommended action
601—Diskette Controller Error	Diskette controller circuitry or diskette drive circuitry incorrect.	<ol style="list-style-type: none">1. Run the Computer Setup (F10) utility.2. Verify and replace cables.3. Clear CMOS.4. Replace diskette drive.5. Replace the system board.
605—Diskette Drive Type Error	Mismatch in drive type.	<ol style="list-style-type: none">1. Run the Computer Setup (F10) Utility.2. Disconnect any other diskette controller devices (tape drives).3. Clear CMOS.
912—Computer Cover Has Been Removed Since Last System Start Up	N/A	No action required.
914—Coil is not Connected	Mechanism is missing or not connected.	<ol style="list-style-type: none">1. Reconnect or replace ing mechanism.2. Reseat or replace ing mechanism cable.
916—Power Button Not Connected	The power button is not connected.	Connect power button.
917—Front Audio Not Connected	The front audio cable is not connected.	Connect front audio cable.
918—Front USB Not Connected	Front USB is not connected.	Connect front USB cable.
960—CPU Overtemp occurred	The ambient temperature could exceed operating limits (maximum=95F), or there are obstructions to airflow, including dust buildup.	<ol style="list-style-type: none">1. Be sure you are not operating the system in an environment that exceeds 95F.2. Disconnect power and open the access panel.3. Verify that cables are not blocking processor heatsink fans or front fan (if installed).4. Verify that there is not excessive dust on major components.5. If airflow is acceptable and there is not excessive dust, the thermal sensing circuitry has failed on the processors or on the system board. You must replace the processors and/or the system board.
1720—SMART Hard Drive Detect Imminent Failure	Hard drive is about to fail. (Some hard drives have a firmware patch that fixes erroneous error messages.)	<ol style="list-style-type: none">1. Determine if hard drive is giving correct error message.2. Run the Drive Protection System test (if applicable).3. Apply firmware patch (if applicable). See http://www.hp.com/support.4. Back up contents and replace the hard drive.
1780—Disk 0 Failure	The drive is not installed correctly or has failed.	<ol style="list-style-type: none">1. Be sure that any jumpers are set correctly, and that power and drive cables are connected, both to the drive and the system board.2. Verify that the cables are the correct cables for your computer model. If this message persists, your workstation might require service.

Table 6-18 POST error messages (continued)

Screen message	Probable cause	Recommended action
1781—Disk 1 Failure	The drive is not installed correctly or has failed.	<ol style="list-style-type: none">1. Be sure that any jumpers are set correctly and that power and drive cables are connected, both to the drive and the system board.2. Verify that the cables are the correct cables for your computer model. If this message persists, your workstation might require service.
1782—Disk Controller Failure	Hard drive circuitry error.	<ol style="list-style-type: none">1. Run the Computer Setup (F10) utility.2. Clear CMOS.3. Verify cable seating and jumper settings.4. Run hard-drive diagnostics.5. Disconnect additional drives.6. Run the Drive Protection System test (if available).7. Replace the hard drive.8. Replace the system board.
1790—Disk 0 Error	The drive is not installed correctly or has failed.	<ol style="list-style-type: none">1. Be sure that any jumpers are set correctly and that power and drive cables are connected to both the hard drive and the system board.2. Verify that the cables are the correct cables for your computer model. If this message persists, you may need service for your workstation.
1791—Disk 1 Error	The drive is not installed correctly or has failed.	<ol style="list-style-type: none">1. Be sure that any jumpers are set correctly and that power and drive cables are connected to both the hard drive and the system board.2. Verify that the cables are the correct cables for your computer model. If this message persists, you may need service for your workstation.
1792—Secondary Disk Controller Failure	Hard drive circuitry error.	<ol style="list-style-type: none">1. Run the Computer Setup (F10) utility.2. Clear CMOS.3. Verify cable seating/jumper settings.4. Run hard-drive diagnostics.5. Disconnect additional drives.6. Run the Drive Protection System test (if available).7. Replace the hard drive.
1793—Secondary Controller or Disk Failure	Hard drive circuitry error.	<ol style="list-style-type: none">1. Run the Computer Setup (F10) Utility.2. Clear CMOS.3. Verify cable seating and jumper settings.4. Run hard-drive diagnostics.5. Disconnect additional drives.6. Run the Drive Protection System test (if available).7. Replace the hard drive.
1801—Microcode Patch Error	Processor not supported by ROM BIOS.	Upgrade BIOS to proper version.

Table 6-18 POST error messages (continued)

Screen message	Probable cause	Recommended action
1802—Processor Not Supported	The system board does not support the processor.	Replace the processor with a compatible one.
1803-BIOS Update Needed for Processor	This BIOS revision does not support the installed processor.	Install the latest BIOS downloaded from http://www.hp.com .
1998—Master Boot Record has been lost	The previously saved copy of the MBR is corrupted.	Run the Computer Setup (F10) Utility and save the MBR of the current bootable disk.
Invalid Electronic Serial Number	Electronic serial number is corrupted	<ol style="list-style-type: none">1. Run the Computer Setup (F10) Utility.2. If the setup utility already has data in the field, or it will not allow the serial number to be entered, see http://www.hp.com.3. Download and run the sp5572.exe (snzero.exe) utility.4. Run the Computer Setup (F10) Utility again and try to enter the serial number under Security>System ID.5. Ssave the changes.
ECC Multiple Bit Error Detected in Memory Module	The chipset has detected more than one bad bit in a 64-bit quadword of the memory array.	Replace the memory module.
Parity Check 2	Parity RAM failure.	Run the Computer Setup (F10) Utility and the Diagnostic utilities.

7 Configuring RAID devices

This chapter describes how to configure SAS and SATA RAID devices, and includes these topics:

Topics

[Maximum hard drive configurations on page 146](#)

[Configuring SATA RAID devices on page 147](#)

[Configuring SAS RAID devices on page 150](#)

For additional information about configuring RAIDs, see http://www.hp.com/support/RAID_FAQs. For information about preparing the workstation for RAID configuration, see http://www.hp.com/support/workstation_manuals.

Maximum hard drive configurations

This section lists the maximum number of hard drives supported on HP workstations for RAID configurations.

 **NOTE:** This section applies to internal workstation configurations that do not use add-in cards and JBODs.

 **TIP:** Use the table values to determine workstation-specific maximum number of hard drives as discussed the sections below.

Table 7-1 Maximum hard drives

Workstation	SATA hard drive	SATA SFF* hard drive	SAS hard drive
Z800	5	6	5
Z600	3	4	3
Z400	4	4	4

* Small form factor hard drive

Configuring SATA RAID devices

This section describes how to use the Intel Matrix Storage Manager option ROM Configuration utility to set up and manage SATA RAID volumes.

The following SATA RAID configurations are supported on this workstation:

- Up to the workstation-specific maximum number of internal SATA hard disk drives and eSATA drives (if you use an optional eSATA bulkhead cable)
- Intel Matrix Storage Manager (IMSM) for Windows

If only a single HDD is attached, the Intel Matrix Storage Manager option ROM does not execute. Associated messages are not displayed.

The Intel SATA AHCI BIOS executes when you select **RAID+AHCI** for the SATA emulation mode. This BIOS is only used to support serial-attached optical drives.

This section does not apply to configuring SATA RAID in the Linux environment. For Linux SATA RAID, refer to the Software RAID in Linux Workstations section in the *HP Workstations for Linux User Guide* at http://www.hp.com/support/linux_user_manual.

Attaching SATA HDDs

Attach the required minimum number of SATA hard drives for the desired RAID level:

- RAID 0: two or more hard drives
- RAID 1: only two hard drives
- RAID 5: three or more hard drives
- RAID 10: only four hard drives

Configuring system BIOS

Configure the system BIOS to enable embedded SATA RAID functionality.

1. To enter the system BIOS setup, press **F10**.
2. Use the arrow keys to highlight the desired language, and then press **Enter**.
3. Use the arrows to highlight **Storage>Storage Options**, and then press **Enter**.
4. Use the up or down arrow key to highlight **SATA Emulation**.
5. Use the left or right arrow key to select **RAID+AHCI**.
6. To accept the new setting, press **F10**.
7. Use the arrows to highlight **Advanced>Power-On Options**, and then press **Enter**.
8. Use the up or down arrow key to highlight **POST Messages**.
9. Use the left or right arrow key to select **Enable**.
10. To accept the new setting, press **F10**.
11. Use the arrow keys to highlight **Advanced>Device Options**, and then press **Enter**.
12. Use the up or down arrow key to highlight **SATA RAID Option ROM Download**, and then press **Enter**.
13. Use the left or right arrow key to select **Enable**.
14. To accept the new setting, press **F10**.
15. Use the arrows to highlight **File>Save Changes and Exit**, and then press **Enter**.
16. Press **F10** when prompted.

Creating RAID volumes

To create RAID volumes, use the Intel Matrix Storage Manager option ROM Configuration utility.

1. To enter the Intel Matrix Storage Manager option ROM Configuration utility, press **Ctrl+I** when prompted
2. If required, refer the workstation *Maintenance and Service Guide* to make available enough physical drives to create the RAID volume.
3. Use the up or down arrow key to highlight **1. Create RAID Volume**, and then press **Enter**.
4. Type the desired RAID volume name in the Name: field, and then press **Tab**.
5. Use the up or down arrow key to select the RAID level in the RAID Level: field, and then press **Tab**.
6. To display the Select dialog, press **Enter**.
7. Use the up and down arrow keys and Space to mark individual physical as members of the volume.
8. To exit the Select dialog and return to the Create Volume Menu dialog, press **Enter**.
9. If appropriate, use the up or down arrow key to select the Strip Size in the Strip Size: field, and then press **Tab**.
10. Enter the desired volume size in the Capacity: field, and then press **Tab**.
11. Press **Enter** to initiate volume creation.
12. When prompted, press **Y** to acknowledge the warning message and create the volume.
13. Return to step 3 to create additional RAID volumes, or use the up or down arrow key to highlight **4. Exit**, and then press **Enter**.
14. Press **Y** when prompted to confirm the exit.

Configuring SAS RAID devices

Supported configurations

The following RAID configurations are supported on this workstation:

 **NOTE:** This section does not apply to configuring SAS RAID in the Linux environment. For Linux SAS RAID information, including supported configurations, refer to *Installing and Configuring SAS Hardware RAID on HP Linux Workstations* at http://www.hp.com/support/xw8600_manuals.

- Up to the workstation-specific maximum number of internal SAS hard disk drives
- LSI MegaRAID Storage Manager (MSM) for Windows

The following RAID configurations are supported on this workstation:

- RAID 0 – Striped disk array (IS)
 - Two drive minimum
 - Improved I/O performance
 - No fault tolerance
- RAID 1 — Mirrored disk array (IM)
 - Two drives
 - 100% redundancy
 - Can recover from single drive failure
 - Improved read performance
- RAID 1E (IME)
 - Three drives minimum
 - Can be an odd number of drives
 - Can always recover from a single drive failure and, in some cases, can recover from two drive failures

SAS RAID 0 configuration

Use the following procedure to configure an Integrated Striped (IS) volume with the BIOS-based configuration utility. The procedure assumes that the system has the required disk and disk controllers.

1. Start the LSI Corporation Configuration Utility. During BIOS start up, you are prompted to **Press Ctrl-C to start LSI Corp. Configuration Utility**.
2. On the Main menu of the BIOS-based configuration utility, use the arrow keys to select an adapter.
3. Press **Enter** to go to the Adapter Properties screen.
4. On the Adapter Properties screen, use the arrow keys to select **RAID Properties**, and press **Enter** to go to the New Array Type screen.
5. In the Select New Array Type screen, use the arrow keys to select **Create IS Volume**. Press **Enter** to go to the Create New Array screen.
6. In the Create New Array screen, use the arrow keys to select the first disk for the IS volume. Then use the arrow keys to move to the RAID Disk column for this disk, and press Space and **+** or **-** to select **Yes** as the value for this column.

If partitions are defined on the selected disk, a message appears warning you that data on the disk will be lost when the striped volume is created.

7. Press **M** to migrate, or **D** to delete the data on the drive.
8. To select additional drives for the striped volume, up to the workstation-specific maximum number, repeat the previous steps.
9. When all drives are selected, press **C** to create the array once. Use the arrow keys to move to **Save changes then exit this menu** and press **Enter**.
10. When the new array is created, the Adapter Properties screen appears. Press **Esc** twice and select **Exit**.

SAS RAID 1 configuration

Use the following procedure to configure an Integrated Mirroring (IM) volume with the BIOS-based configuration utility. The procedure assumes that the system has the required drives and drive controllers.

1. Start the LSI Corporation Configuration Utility. During BIOS start up, you are prompted to **Press Ctrl-C to start LSI Corp. Configuration Utility**.
2. On the Main menu of the BIOS-based configuration utility, use the arrow keys to select an adapter.
3. Press **Enter** to go to the Adapter Properties screen.
4. On the Adapter Properties screen, use the arrow keys to select **RAID Properties**, and press **Enter** to go to the New Array Type screen.
5. In the Select New Array Type screen, use the arrow keys to select **Create IM Volume**. Press **Enter**.
6. To configure a two-disk mirrored volume with an optional hot spare disk:
 - a. In the Create New Array screen, use the arrow keys to select the primary disk for the IM volume (the disk with the data you want to mirror.)
 - b. Use the arrow keys to move to the RAID Disk column for this disk and press Space to select **Yes** as the value.

If partitions are defined on the selected disk, a message appears warning you that data on the disk will be lost when the mirrored volume is created.
 - c. Press **M** to migrate or **D** to delete the data on the drive.
 - d. The value in the Array Disk column changes to Primary.

Use the arrow keys to select the secondary (mirrored) disk for the IM volume, and then select **Yes** as the value for the Array Disk column.

If partitions are defined on this disk, a message warns that data on the disk will be lost when the mirrored volume is created.
 - e. Press **Delete** to confirm erasing data from the disk, or press any other key to deselect the disk.
7. When all drives are selected, press **C** to create the array once. Use the arrow keys to move to **Save changes then exit this menu** and press **Enter**.
8. When the new array is created, the Adapter Properties screen appears. Press **Esc** twice and select **Exit**.

SAS RAID 1E configuration

Use the following procedure to configure an Integrated Mirroring Extended (IME) volume with the BIOS-based configuration utility. The procedure assumes that the system has the required disk and disk controllers.

1. Start the LSI Corporation Configuration Utility. During BIOS start up, you are prompted to **Press Ctrl-C to start LSI Corp. Configuration Utility**.
2. On the Main menu of the BIOS-based configuration utility, use the arrow keys to select an adapter.
3. Press **Enter** to go to the Adapter Properties screen.
4. On the Adapter Properties screen, use the arrow keys to select **RAID Properties**, and press **Enter** to go to the New Array Type screen.
5. In the Select New Array Type screen, use the arrow keys to select **Create IME Volume**. Press **Enter**.
6. To configure a mirrored volume or an optional hot spare drive with up to the workstation-specific maximum number of drives:
 - a. In the Create New Array screen, use the arrow keys to select the first disk for the IME volume.
 - b. Use the arrow keys to move to the RAID Disk column for this disk, and then use the **+** or **-** keys to select **Yes** as the value.

If partitions are defined on the selected disk, a message appears warning that the data on the disk will be lost when the mirrored volume is created.
 - c. Press **M** to migrate, or **D** to delete the data on the drive.
 - d. Use the arrow keys to select the next disk for the IME volume, and then select **Yes** as the value for the Array Disk column.

If partitions are defined on this disk, a message warns you that data on the disk will be lost when the mirrored volume is created.
 - e. Press **Delete** to confirm erasing data from the disk, or press any other key to deselect the disk.
 - f. Repeat the previous steps to select up to the workstation-specific maximum number of drives for the IME volume, including configuration of a hot spare.
7. When all drives are selected, press **C** to create the array once. Use the arrow keys to move to **Save changes then exit this menu** and press **Enter**.
8. When the new array is created, the Adapter Properties screen appears. Press **Esc** twice and select **Exit**.

Deleting RAID volumes

Use the LSI Logic Corporation Configuration Utility to delete SAS RAID volumes.

1. Start the LSI Corporation Configuration Utility. During BIOS start up, you are prompted to **Press Ctrl-C to start LSI Corp. Configuration Utility**.
2. On the Main menu of the BIOS-based configuration utility, use the arrow keys to select an adapter.
3. Press **Enter** to go to the Adapter Properties screen.
4. In the Select New Array Type screen, use the arrow keys to select **New Existing Array**.
5. In the View Array screen, use the arrow keys to select **Manage Array**. Press **Enter**.
6. In the Manage Array screen, use the arrow keys to select **Delete Array**. Press **Enter**. Press **Y** to delete the array and exit to the adapter properties screen.

8 Configuring password security and resetting CMOS

This chapter describes how to configure password security and to reset CMOS, and includes these topics:

Topics

[Preparing to configure passwords on page 155](#)

[Resetting the password jumper on page 155](#)

[Resetting the password jumper on page 155](#)

Preparing to configure passwords

The Computer Setup (F10) Utility enables you to create setup and power-on passwords.

When a power-on password is set, the power-on password is required to access the computer.

If a setup password is set, either the setup password or the power-on password can be used to access the system; but, only the setup password can be used to access the Computer Setup (F10) Utility.

When both passwords are created, the setup password can also be used in place of the power-on password as an override to log into the workstation (a useful feature for a network administrator).

If you forget a password, follow the Resetting the password jumper instructions in the following section.

Resetting the password jumper

To disable the power-on or setup password features and clear the power-on and setup passwords:

- △ **WARNING!** To reduce the risk of personal injury from electrical shock and hot surfaces, be sure to disconnect the power cord from the wall outlet and allow the internal system components to cool before touching.
 - △ **CAUTION:** When the workstation is plugged in, the power supply always has voltage applied to the system board even when the workstation is turned off. Failure to disconnect the power cord can result in damage to the system.
 - △ **CAUTION:** Static electricity can damage the electronic components of the workstation or optional equipment. Before beginning these procedures, be sure that you are discharged of static electricity by briefly touching a grounded metal object.
1. Shut down the operating system, and then power off the workstation and any external devices. Disconnect the workstation power cord and any external devices from the power outlets.
 2. Disconnect the keyboard, monitor, and any other external devices that are connected to the workstation.

3. Remove the access panel.
4. Locate the password header and jumper. The password header is E49.

 **NOTE:** Ensure that the AC power cord is disconnected from the power outlet.

The password jumper is green so that it can be easily identified. For assistance locating the password jumper and other system board components, see the service label located on the inside of the workstation access panel, or see [System board components on page 57](#).



5. Remove the jumper from the default position on pins 1 and 2. The jumper can be temporarily stored on either pin 1 or pin 2.
6. Replace the access panel.
7. Reconnect the external equipment.
8. Plug in and power on the workstation. Allow the operating system to start. This process clears the current passwords and disables the password features.
9. To establish new passwords, repeat steps 1 through 4, replace the password jumper on both pin 1 and pin 2, and repeat steps 6 through 8. If required, establish new passwords using the Computer Setup (F10) Utility.

Clearing and Resetting the CMOS

The CMOS of the workstation stores information about the workstation configuration. This section describes the steps necessary to successfully clear and reset the CMOS.

Using the CMOS Button

Follow the steps below to clear CMOS using the Clear CMOS button:

-
-  **WARNING!** To reduce the risk of personal injury from electrical shock and hot surfaces, be sure to disconnect the power cord from the wall outlet and allow the internal system components to cool before touching.
 -  **CAUTION:** When the workstation is plugged in, the power supply always has voltage applied to the system board even when the workstation is powered off. Failure to disconnect the power cord can result in damage to the system

CAUTION: Static electricity can damage the electronic components of the workstation or optional equipment. Before beginning these procedures, be sure that you are discharged of static electricity by briefly touching a grounded metal object.

1. Shut down the operating system, and then power off the workstation and any external devices. Disconnect the workstation power cord and any external devices from the power outlets.
2. Disconnect the keyboard, monitor, and any other external devices that are connected to the workstation.
3. Remove the access panel.

 **CAUTION:** Pushing the Clear CMOS button resets CMOS values to factory defaults and erases any customized information, asset numbers, and special settings. It is important to back up the workstation CMOS settings before resetting them in case they are necessary later. To back up the CMOS settings, use the Computer Setup (F10) Utility and select **Save to Diskette** from the File menu.

4. Locate, press, and hold the CMOS button for five seconds.

 **NOTE:** Be sure that the AC power cord is disconnected from the power outlet. The CMOS button does not clear CMOS if the power cord is connected.

NOTE: For assistance locating the CMOS button and other system board components, see [System board components on page 57](#).

5. Replace the access panel.
6. Reconnect any external devices.
7. Plug in and power on the workstation.

The workstation powers up for three to five seconds, then powers down.

Using the Computer Setup (F10) Utility to Reset CMOS

1. Access the Computer Setup (F10) Utility menu. When the Computer Setup message appears in the lower-right corner of the screen, press **F10**. Press **Enter** to bypass the title screen, if necessary.

 **NOTE:** If you do not press the **F10** key while the message is displayed, the workstation must be powered off, then on again, to access the utility.

2. From the Computer Setup (F10) Utility menu, select **File>Set Defaults**, and then select **Exit**. This restores the settings that include boot sequence order and other factory settings. However, it does not force hardware rediscovery.

A Appendix A—Connector pins

Connector pin descriptions

Workstation keyboard connector	Pin	Signal
	1	Data
	2	Unused
	3	Ground
	4	+5 VDC
	5	Clock
	6	Unused

Workstation mouse connector	Pin	Signal
	1	Data
	2	Unused
	3	Ground
	4	+5 VDC
	5	Clock
	6	Unused

Workstation Ethernet connector	Pin	10/100-MbSignal	1000-Mb signal
	1	(+) Transmit Data	TX/RX 0 +
	2	(-) Transmit Data	TX/RX 0 -
	3	(+) Receive Data	TX/RX 1 +
	4	Unused	TX/RX 2 +
	5	Unused	RX/RX 2 -
	6	(-) Receive Data	TX/RX 1 -
	7	Unused	TX/RX 3 +
	8	Unused	TX/RX 3 -

Workstation parallel connector

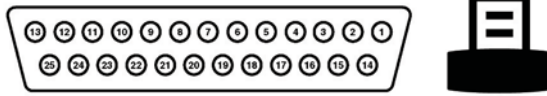

Pin	Signal	Pin	Signal	Pin	Signal
1	Strobe	7	Data Bit 5	13	Select
2	Data Bit 0	8	Data Bit 6	14	Auto Linefeed
3	Data Bit 1	9	Data Bit 7	15	Error
4	Data Bit 2	10	Acknowledge	16	Initialize Printer
5	Data Bit 3	11	Busy	17	Select IN Signal
6	Data Bit 4	12	Paper End	18-25	Ground

Workstation serial connector



Pin	Signal
1	Carrier Detect
2	Receive Data
3	Transmit Data
4	Data Terminal Ready
5	Signal Ground
6	Data Set Ready
7	Request to Send
8	Clear to Send
9	Ring Indicator

Workstation USB connector

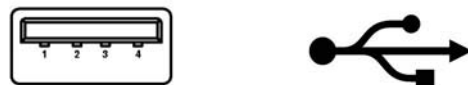

Pin	Signal
1	+5 VDC
2	- Data
3	+ Data
4	Ground

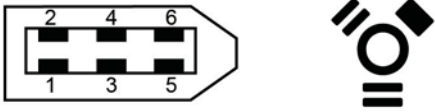
Workstation IEEE 1394 connector	Pin	Signal
	1	Power
	2	GND
	3	TPB-
	4	TPB+
	5	TPA-
	6	TPA+

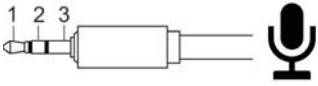
Microphone cable connector (1/8 inch)	Pin	Signal
	1 (Tip)	Audio
	2 (Ring)	Power
	3 (Shield)	Ground

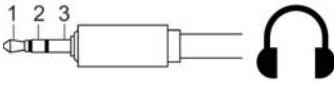
Headphone cable connector (1/8 inch)	Pin	Signal
	1 (Tip)	Audio_Left
	2 (Ring)	Audio_Right
	3 (Shield)	Ground

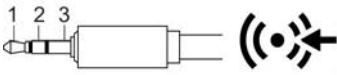
Line-in audio cable connector (1/8 inch)	Pin	Signal
	1 (Tip)	Audio_In_Left
	2 (Ring)	Audio_In_Right
	3 (Shield)	Ground

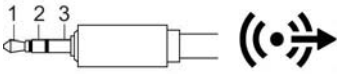
Line-out audio cable connector (1/8 inch)	Pin	Signal
	1 (Tip)	Audio_Out_Left
	2 (Ring)	Audio_Out_Right
	3 (Shield)	Ground

SATA drive connector

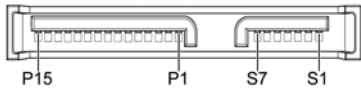

Pin	Signal	Pin	Signal	Pin	Signal
Data Cable		Power Cable		Power Cable	
S1	Ground	P1	3.3V power	P8	5V power
S2*	A+	P2	3.3V power	P9	5V power
S3*	A-	P3	3.3V power	P10	Ground
S4	Ground	P4	Ground	P11	Reserved
S5**	B-	P5	Ground	P12	Ground
S6**	B+	P6	Ground	P13	12V power
S7	Ground	P7	5V power	P14	12V power
* S2 and S3 differential signal pair				P15	12V power
**S5 and S6 differential signal pair					

SAS drive connector

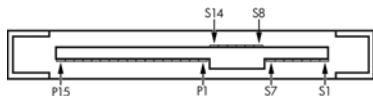

Segment	Pin	Backplane receptacle	Plug and cable receptacles
Primary signal segment	S1	SIGNAL GROUND	
	S2	TP+	RP+
	S3	TP-	RP-
	S4	SIGNAL GROUND	
	S5	RP-	TP-
	S6	RP+	TP+
	S7	SIGNAL GROUND	

SAS drive connector

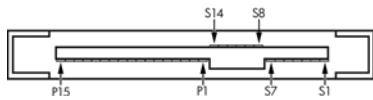

Segment	Pin	Backplane receptacle	Plug and cable receptacles
Secondary signal segment	S8	SIGNAL GROUND	
	S9	TS+	RS+
	S10	TS-	RS-
	S11	SIGNAL GROUND	
	S12	RS-	TS-
	S13	RS+	TS+
	S14	SIGNAL GROUND	
Power segment	P1	V_{33}^c	
	P2	V_{33}^c	
	P3	V_{33}^c precharge ^c	
	P4	GROUND	
	P5	GROUND	
	P6	GROUND	
	P7	V_5^c precharge ^c	
	P8	V_5^c	
	P9	V_5^c	
	P10	GROUND	
	P11	READY LED ^d	
	P12	GROUND	
	P13	V_{12} precharge ^c	
	P14	V_{12}^c	
	P15	V_{12}^c	

Workstation VGA connector

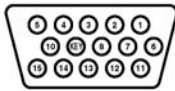

Pin	Signal	Pin	Signal	Pin	Signal
1	Red Analog	6	GND	11	Monitor ID
2	Green Analog	7	GND	12	DDC Serial Data
3	Blue Analog	8	GND	13	Horizontal Sync
4	Monitor ID	9	+5 VDC	14	Vertical Sync
5	GND	10	GND	15	DDC Serial Clock

DVI-I cable connector

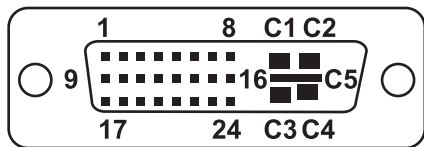

Pin	Signal	Pin	Signal
1	T.M.D.S DATA 2-	16	HOT PLUG DETECT
2	T.M.D.S DATA 2+	17	T.M.D.S DATA 0-
3	T.M.D.S DATA 2/4 SHIELD	18	T.M.D.S DATA 0+
4	T.M.D.S DATA 4-	19	T.M.D.S DATA 0/5 SHIELD
5	T.M.D.S DATA 4+ 2	0	T.M.D.S DATA 5-
6	DDC CLOCK	21	T.M.D.S DATA 5+
7	DDC DATA	22	T.M.D.S CLOCK SHIELD
8	ANALOG VERT. SYNC	23	T.M.D.S CLOCK+
9	T.M.D.S DATA 1-	24	T.M.D.S CLOCK-
10	T.M.D.S DATA 1+		
11	T.M.D.S DATA 1/3 SHIELD	C1	ANALOG RED
12	T.M.D.S DATA 3-	C2	ANALOG GREEN
13	T.M.D.S DATA 3+	C3	ANALOG BLUE
14	+5V POWER	C4	ANALOG HORZ SYNC
15	GND	C5	ANALOG GROUND

24-pin main power cable connector

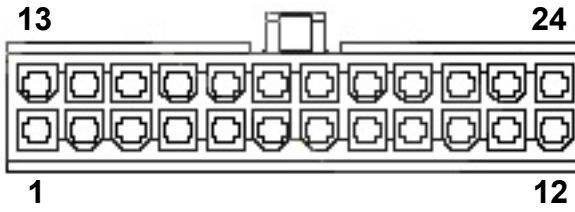

1	+3.3V	7	GND	13	+3.3V	19	GND
2	+3.3V	8	POK	14	-12V	20	GND
3	GND	9	+5 Vaux	15	GND	21	+5V
4	+5V	10	+12 V-B	16	PS_ON_L	22	+5V
5	GND	11	+12 V-B	17	GND	23	+12V-D
6	+5V	12	+12V-D	18	GND	24	GND

4-pin power (CPU/memory/aux. sys. board) cable connector

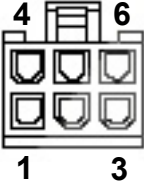

Pin	Color	Signal
1	BLK	GND
2	BLK	GND
3	WHT	+12 VCPU
4	WHT	+12 VCPU

6-pin power (auxiliary PCI Express) cable connector	Pin	Color	Signal
	1	YEL	+12 V-D
	2	YEL	+12 V-D
	3	YEL	+12 V-D
	4	BLK	GND
	5	BLK	GND
	6	BLK	GND

CAUTION: Ensure that you can differentiate between which power cable connects to the PCI Express x16 graphics card and which power cable connects to the system board. These two cables have different pin counts and different colors. The PCI Express power cable has a 6-pin black connector, and the system board power cable has a 4-pin white connector. When power is present, you must never connect the PCI Express power cable to the system board. If you do so, the system board can be damaged and your warranty voided. To see a picture of the PCI Express cable and where it must be connected, see [PCI Express cards on page 78](#).

NOTE: The 6-pin power (auxiliary PCI Express) is only required with high-powered graphics cards.

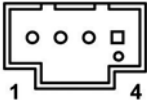
Workstation AUX_IN connector	Pin	Signal
	1	AUX_LEFT
	2	AGND
	3	AGND
	4	AUX_RIGHT

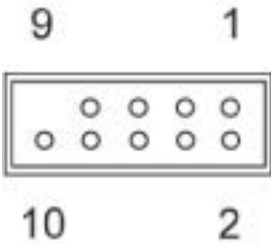
Internal USB system board 2x5 connector	Pin	Signal
	1	+5V
	2	+5V
	3	USB6#
	4	USB7#

Internal USB system board 2x5 connector	Pin	Signal
<p>CAUTION: Possible equipment damage.</p> <p>The 2x5 system board connector can be mated to either a wide 2x5 option cable connector or a narrow 1x5 option cable connector.</p> <p>To prevent damage to the connectors, always connect a narrow 1x5 option cable connector to pins 1,3,5, and 7 only of the 2x5 system board connector (pin 9 is not keyed on the system board connector).</p>	5	USB6
	6	USB7
	7	GND
	8	GND
	9	(not keyed)
	10	Not connected

Workstation processor, PCI, and rear chassis fan connector	Pin	Signal
	1	Ground
	2	+12V
	3	Tach
	4	CMD
	5	MT

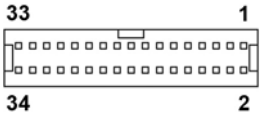
Workstation FDD connector	Pin	Signal	Pin	Signal
	1	Ground	18	FLP_DIR#
	2	FLP_LOWDEN#	19	Ground
	3	Tach	20	FLP_STEP#
	4	FLP_WDO	21	Ground
	5	MT	22	FLP_STEP#
	6	Unused	23	Ground
	7	Ground	24	FLP_WRTEN#
	8	FLP_INDEX#	25	Ground
	9	Ground	26	FLP_TRACK#
	10	FLP_MOTOR#	27	Ground
	11	Ground	28	FLP_WP#
	12	Unused	29	Ground
	13	Ground	30	FLP_RD_D#
	14	FLP_SEL_A#	31	Ground
	15	Ground	32	FLP_HD_SEL#

Workstation FDD connector	Pin	Signal	Pin	Signal
	16	Unused	33	Ground
	17	Ground	34	FLP_DSKCHG#

Workstation internal serial connector	Pin	Signal	Pin	Signal
	1	DTR2#	9	+5V
	2	RXD2	10	+3.3V AUX
	3	CTS2#	11	RTS2#
	4	DSR2#	12	+3.3V
	5	TXD2	13	DCD2#
	6	+3.3V AUX	14	-12V
	7	Ground	15	+12V
	8	Ground		

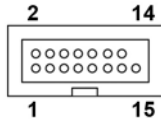

B Appendix B—System board designators

This appendix lists the system board designators for this system.

Designator	Silkscreen	Component
MTG1-MTG10	N/A	Mounting holes
E14	E14	Boot block header/jumper
E49	E49	Clear password header/jumper
J20	SLOT 5 PCI	PCI slot
J21	SLOT 6 PCI	PCI slot
J22	Slot 7 PCI	PCI slot
J33	SLOT 3 PCIe x8 (4)	PCI Express slot
J31	SLOT1 PCIe x1	PCI Express slot
J32	SLOT4 PCIe2 x16 75W + 75W	PCI Express slot
J41	SLOT2 PCIe2 x16 75W + 75W	PCI Express slot
P60-64	SATA0 – SATA4	SATA Connectors
CN6	CN6	External SATA
J50, P53	PARALLEL/SERIAL	Parallel port and serial port stack connector
P52	P52	Optional serial port
J68	KBD_MS	Stacked keyboard/mouse connector
J9	J9	Stacked RJ 45/dual USB
J10	QUAD USB	Quad stacked USB
CN7	USB	Single vertical USB
J83	J83	Triple stacked audio jack
SW50	CMOS	Clear CMOS switch/push button
P1	P1	Power supply connector (24-pin)
P3	PWRCPU	Processor power
P10	FDD	Diskette driver connector
P11	AUX-IN	Auxiliary audio connector
P23	FRNT AUDIO	Front panel audio header
P24	FRNT USB	Front panel USB header
P25	INT USB	Internal USB header

Designator	Silkscreen	Component
U1037	U1037	Internal Type A USB
P29	P29	HDD LED connector
P5	CONTROL PANEL	Main power/HDD LED/internal speaker connector
P70	CPU FAN	Primary processor fan header
P8	SYS FAN	Chassis fan header
P9	PCI FAN	PCI fan header
XBT1	BATTERY	Battery retainer
XMM1	DIMM1	Memory slot
XMM2	DIMM3	Memory slot
XMM3	DIMM2	Memory slot
XMM4	DIMM4	Memory slot
U1	XU1	Primary processor socket
E15	E15	Crisis recovery header/jumper

C Appendix C—Routine care

General cleaning safety precautions

- Never use solvents or flammable solutions to clean the workstation.
- Never immerse any component in water or cleaning solutions; apply any liquids to a clean cloth and then use the cloth on the component.
- Always unplug the workstation before cleaning the keyboard, mouse, or air vents.
- Always disconnect the keyboard before cleaning it.
- Wear safety glasses equipped with side shields when cleaning the keyboard.

Cleaning the workstation case

- Follow the service consideration ([Service considerations on page 52](#)) presented before cleaning the workstation.
- To remove light stains or dirt, use plain water with a clean, lint-free cloth or swab.
- For stronger stains, use a mild dish washing liquid diluted with water. Rinse well by wiping it with a cloth or swab dampened with clear water.
- For stubborn stains, use isopropyl (rubbing) alcohol. No rinsing is required because the alcohol evaporates quickly and does not leave a residue.
- After cleaning, always wipe the workstation with a clean, lint-free cloth.
- Occasionally, clean the air vents on the workstation. Lint and other foreign matter can block the vents and limit the airflow.

Cleaning the keyboard

△ **CAUTION:** Use safety glasses equipped with side shields before attempting to clean debris from under the keys.

- Follow the safety precautions presented in [Service considerations on page 52](#) before cleaning the keyboard.
- Visible debris underneath or between the keys can be removed by vacuuming or shaking.
- Canned, pressurized air can be used to clean debris from under the keys. Use caution because too much air pressure can dislodge lubricants applied under the wide keys.
- If you remove a key, use a specially designed key remover to prevent damage to the keys. This tool is available from many electronic supply outlets.

△ **CAUTION:** Never remove a wide key (like the space bar key) from the keyboard. If these keys are improperly removed or installed, the keyboard might not function properly.

- Clean under a key with a swab moistened with isopropyl alcohol and squeezed out. Be careful not to wipe away lubricants necessary for proper key functions. Allow the parts to air dry before reassembly.
- Use tweezers to remove any fibers or dirt in confined areas.

Cleaning the monitor

- Follow the safety precautions presented in [Service considerations on page 52](#) before cleaning the monitor.
- To clean the monitor, wipe the monitor screen with a towelette designed for cleaning monitors or a clean cloth moistened with water.

△ **CAUTION:** Do not use sprays or aerosols directly on the screen—the liquid might seep into the housing and damage a component.

Never use solvents or flammable liquids on the monitor because display or housing damage may result.

Cleaning the mouse

1. Follow the safety precautions presented in [Service considerations on page 52](#) before cleaning the mouse.
2. Remove the mouse ball from the housing by removing the retaining plate.
3. Clean the mouse ball.
4. Pull out any debris from the ball socket, and wipe the ball with a clean, dry cloth.
5. Reassemble the mouse.