

REVISIONS			
REV	DESCRIPTION	DATE	APPROVED
1	RELEASE PER ECO 06V-0717	6/26/06	FJL

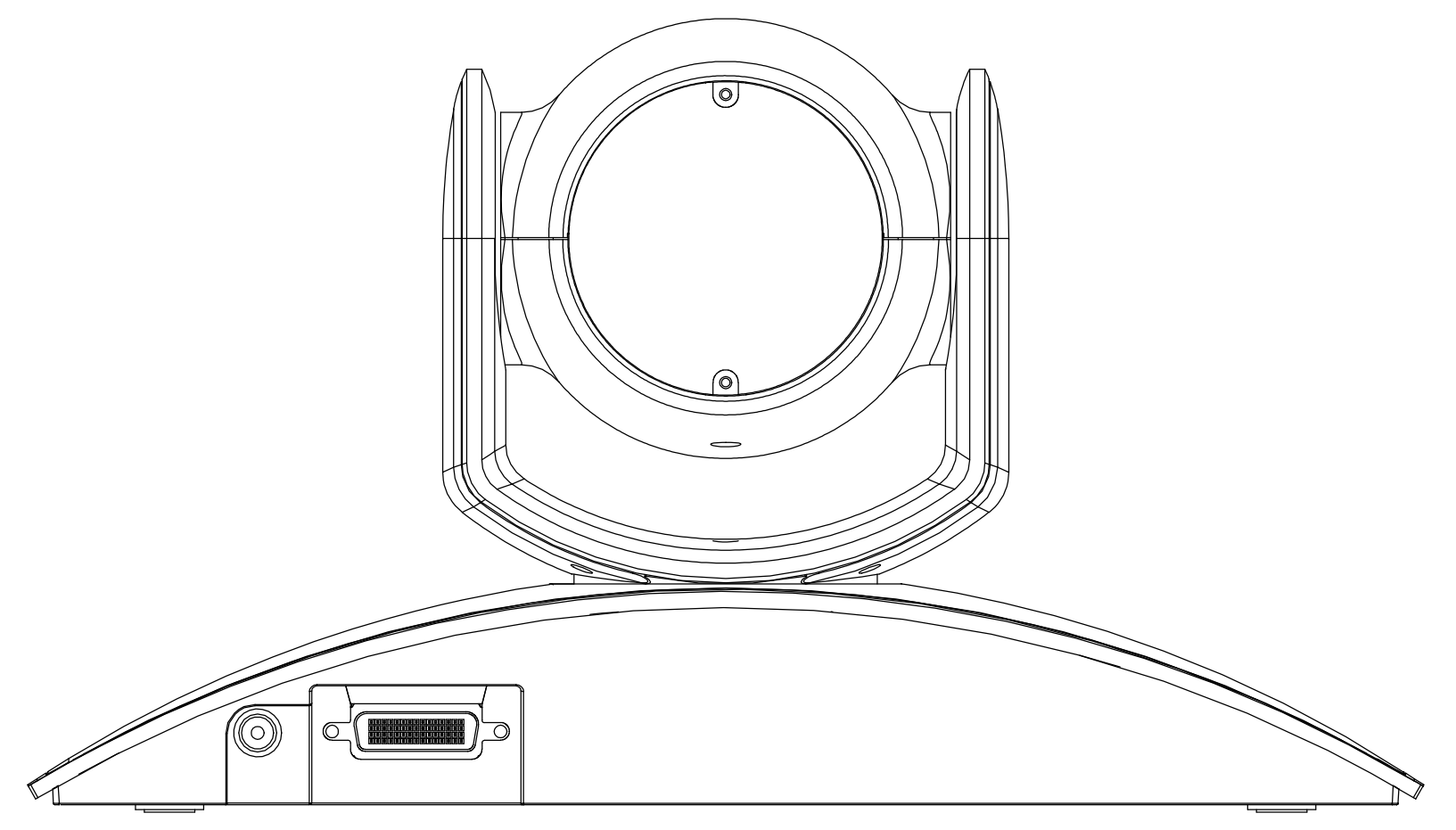
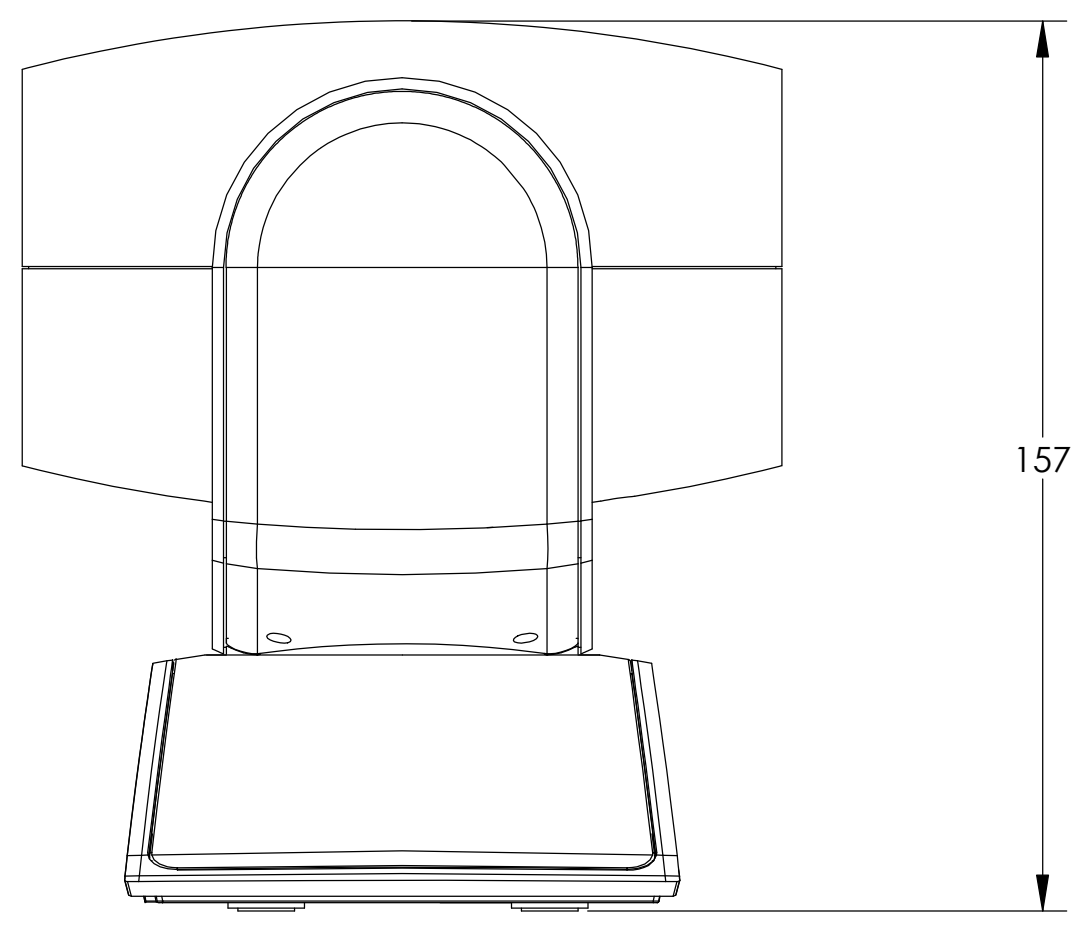
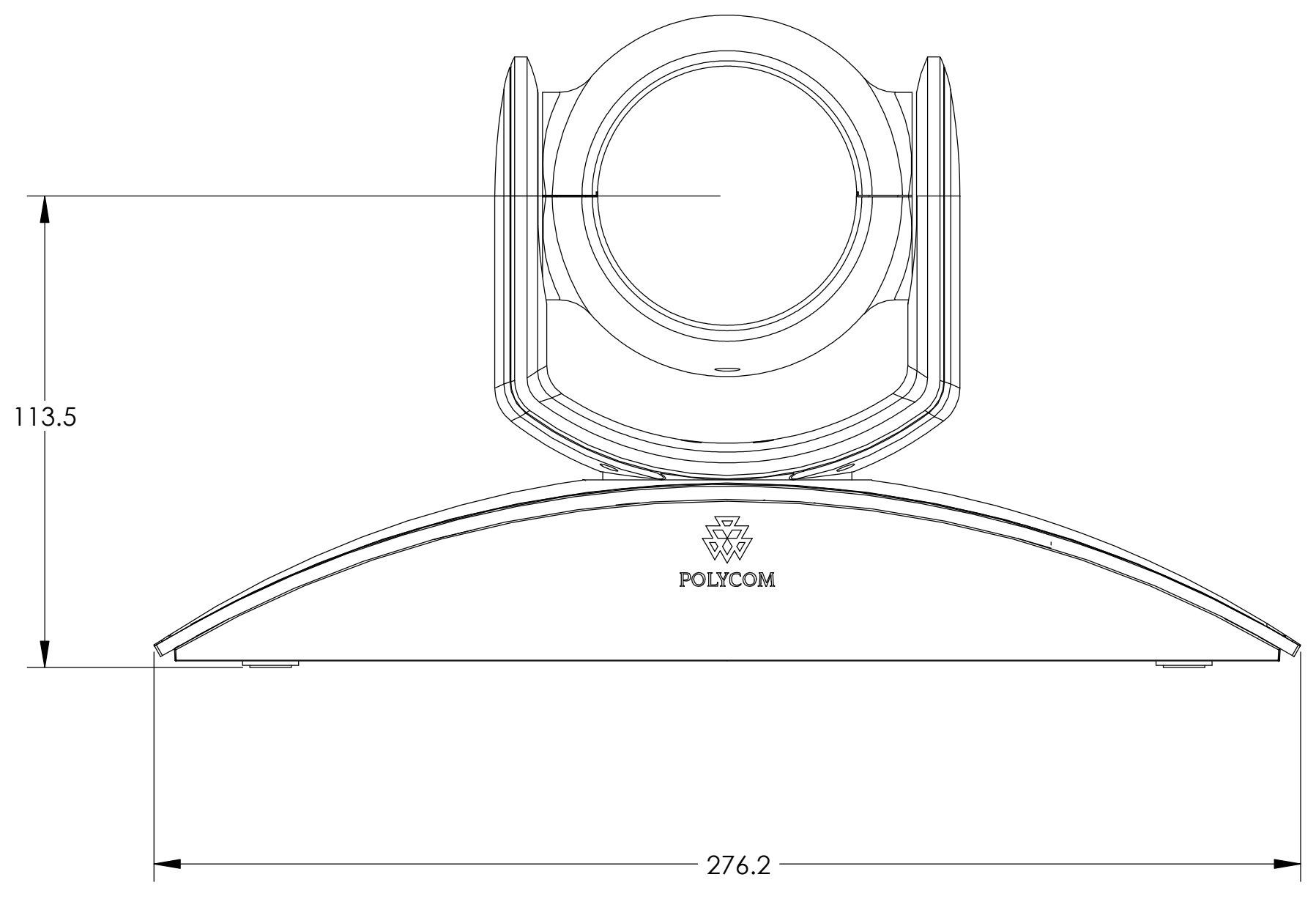
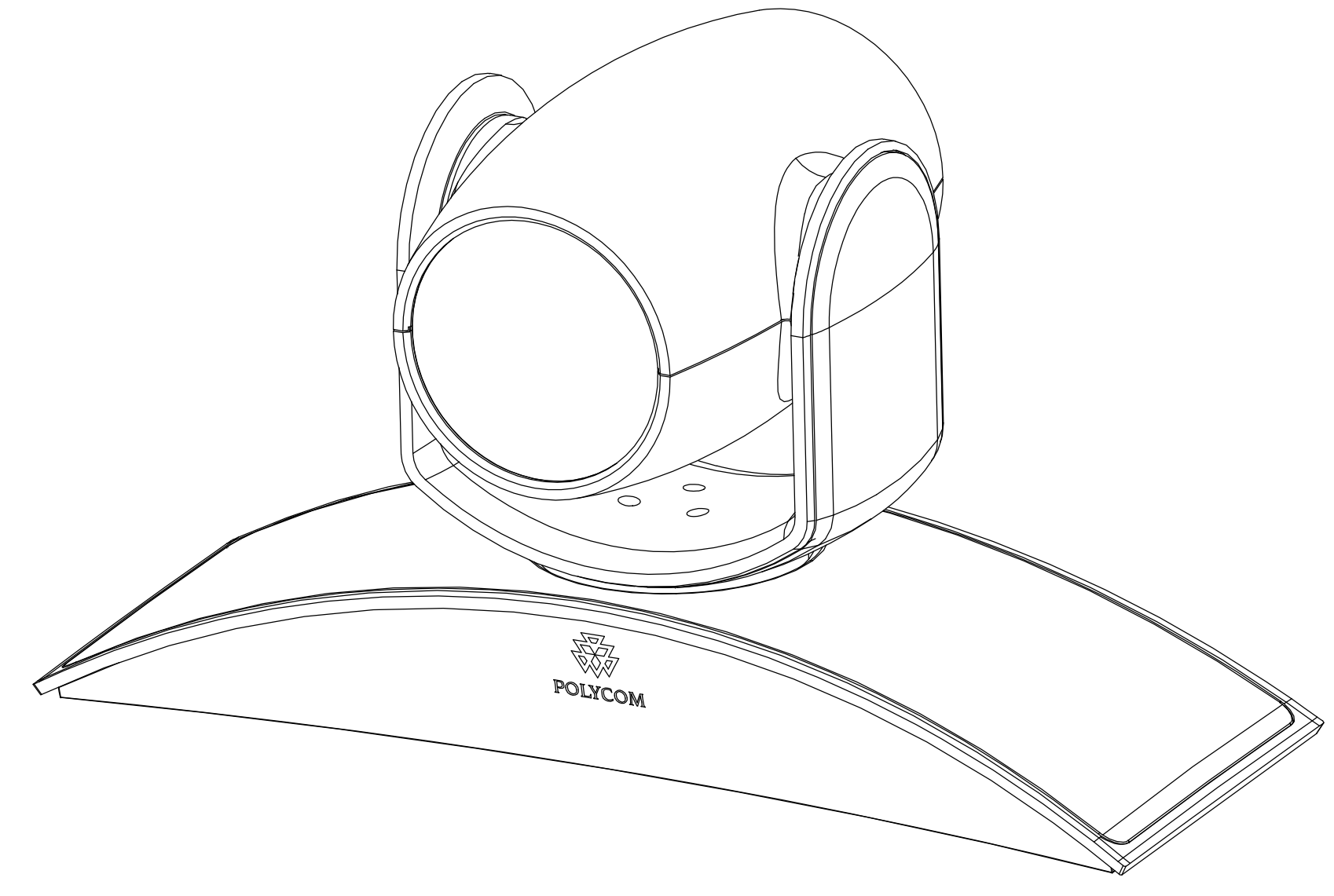
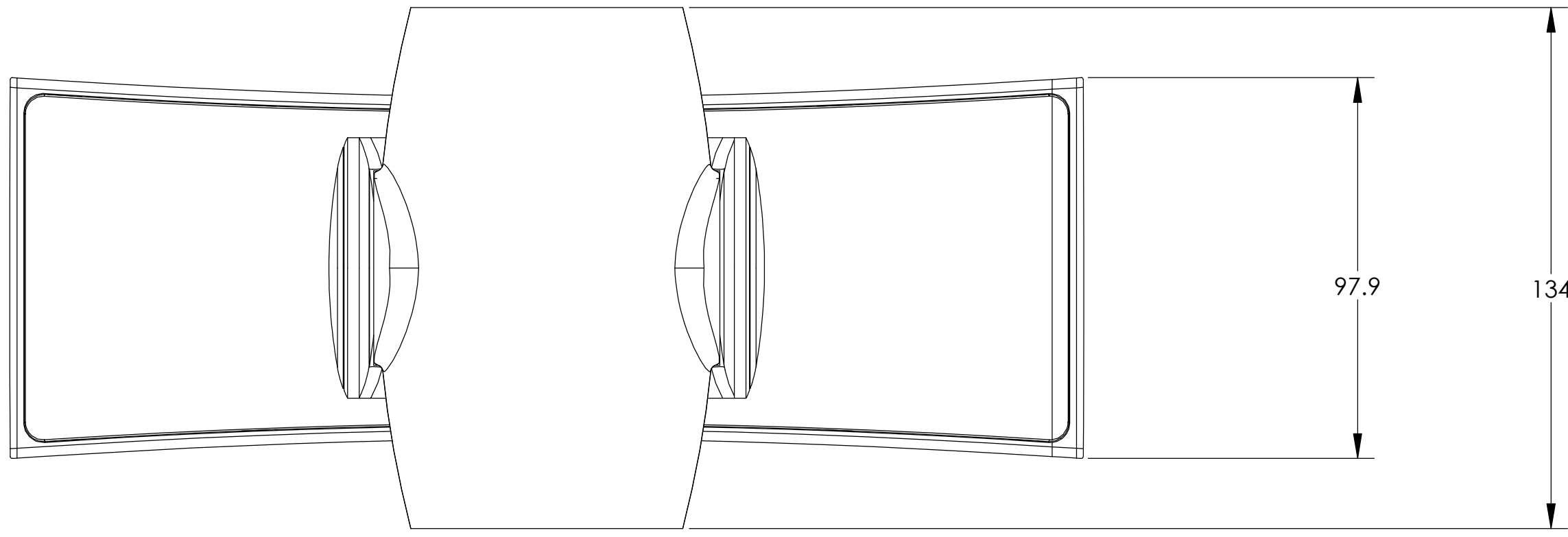

NOTES:
 1.) SCALE: .75
 2.) DIMENSIONS ARE MM

THESE DRAWINGS AND SPECIFICATIONS ARE THE EXCLUSIVE PROPERTIES OF POLYCOM CORPORATION, ISSUED IN STRICT CONFIDENCE AND SHALL NOT, WITHOUT THE PRIOR WRITTEN PERMISSION OF POLYCOM CORPORATION BE REPRODUCED, COPIED, OR USED FOR ANY PURPOSE WHATSOEVER EXCEPT THE MANUFACTURE OF ARTICLES FOR POLYCOM CORPORATION.

CAD INFORMATION
 DWG NAME:
 REF OBJECT:
 PROJECT:
 SUBPROJECT:
 USER:

MATERIAL:
 SEE NOTES

FINISH:
 SEE NOTES

PART OR IDENTIFYING NO.		NOMENCLATURE OR DESCRIPTION		MATERIAL SPECIFICATION		ZONE		ITEM NO.	
PARTS LIST									
UNLESS OTHERWISE SPECIFIED UNITS ARE IN MILLIMETERS. TOLERANCES ARE:				MATERIAL/FINISH NOTED AS APPLICABLE		POLYCOM			
FRACTION	DECIMALS	ANGLES	THIRD ANGLE PROJECTION		TITLE DOC, CAD DWG, EAGLE EYE CAMERA				
.X ± .30	.XX ± .20	± 2 DEG.	APPROVALS						
.XXX ± .10	DRAWN BY: FJL		DATE: 27-Jun-06						
ENGINEER: FJL		APPROVALS:							
DEVIATION FROM INTENDED SHAPE (FLATNESS, ROUNDNESS, SQUARENESS, ETC.) MUST BE WITHIN STATED DIMENSIONAL TOLERANCES.		APPROVALS:		SIZE DIVISION: D		DWG. NO.: 3725-23713-001		REV.: 1	
DO NOT SCALE DRAWING								SHEET 1 OF 1	