

REVISIONS			
REV.	DESCRIPTION	DATE	APPROVED
1	RELEASE PER ECO 08V-0716	6-10-08	FJL

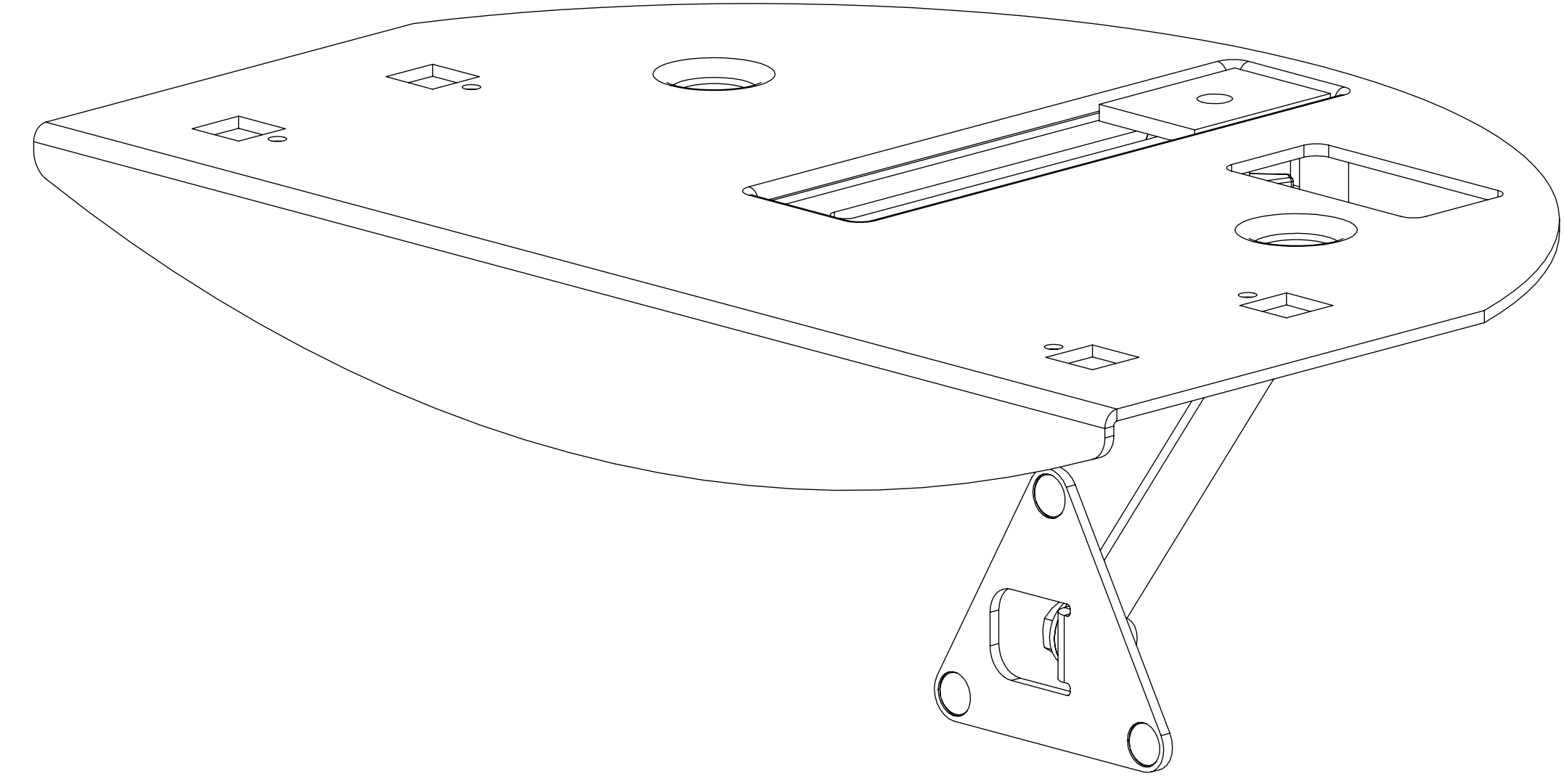

DISPLAY MOUNT

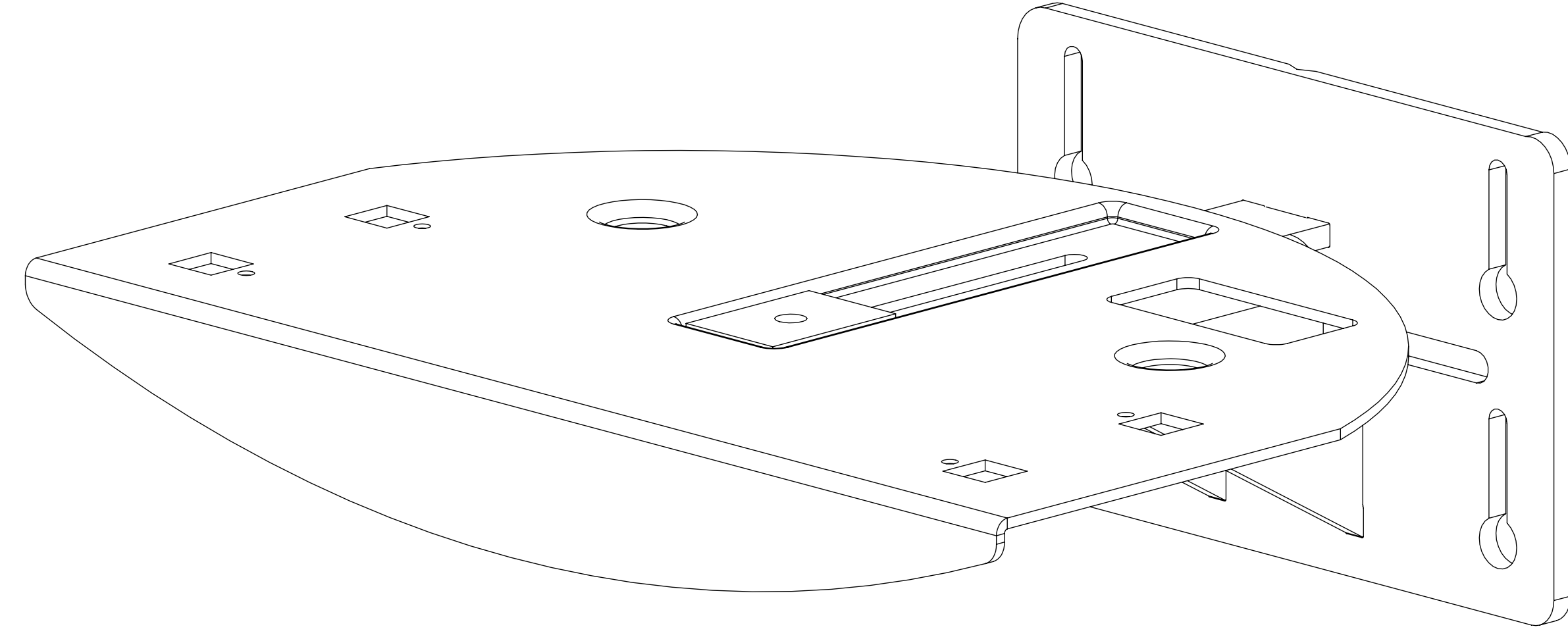

WALL MOUNT

THESE DRAWINGS AND SPECIFICATIONS ARE THE EXCLUSIVE PROPERTIES OF POLYCOM CORPORATION, ISSUED IN STRICT CONFIDENCE AND SHALL NOT, WITHOUT THE PRIOR WRITTEN PERMISSION OF POLYCOM CORPORATION, BE REPRODUCED, COPIED, OR USED FOR ANY PURPOSE WHATSOEVER EXCEPT THE MANUFACTURE OF ARTICLES FOR POLYCOM CORPORATION.

**CAD INFORMATION**  
 DWG NAME:  
 REF OBJECT:  
 PROJECT:  
 SUBPROJECT:  
 USER:

**MATERIAL:**  
 SEE NOTES

**FINISH:**  
 SEE NOTES

UNLESS OTHERWISE SPECIFIED UNITS ARE INCHES. TOLERANCES ARE:

DECIMALS	ANGLES
.X ± .030	± 1.0°
.XX ± .015	
.XXX ± .005	

DEVIATION FROM INTENDED SHAPE (FLATNESS, ROUNDNESS, SQUARENESS, ETC.) MUST BE WITHIN STATED DIMENSIONAL TOLERANCES.

APPROVALS		DATE
DRAWN BY F. LABUSKI		10-Jun-08
ENGINEER		
APPVD.		
APPVD.		

PART OR IDENTIFYING NO.		NOMENCLATURE OR DESCRIPTION		MATERIAL SPECIFICATION	ZONE	ITEM NO.
PARTS LIST						
TITLE DOC, CAD DWG, SHELF, WALL/DISPLAY, EAGLE EYE						
SIZE	DIVISION	DWG. NO.	REV.			
D		3725-28689-001	1			
DO NOT SCALE DRAWING						SHEET 1 OF 3

# DISPLAY MOUNT

## NOTES:

1.) DIMENSIONS ARE INCHES

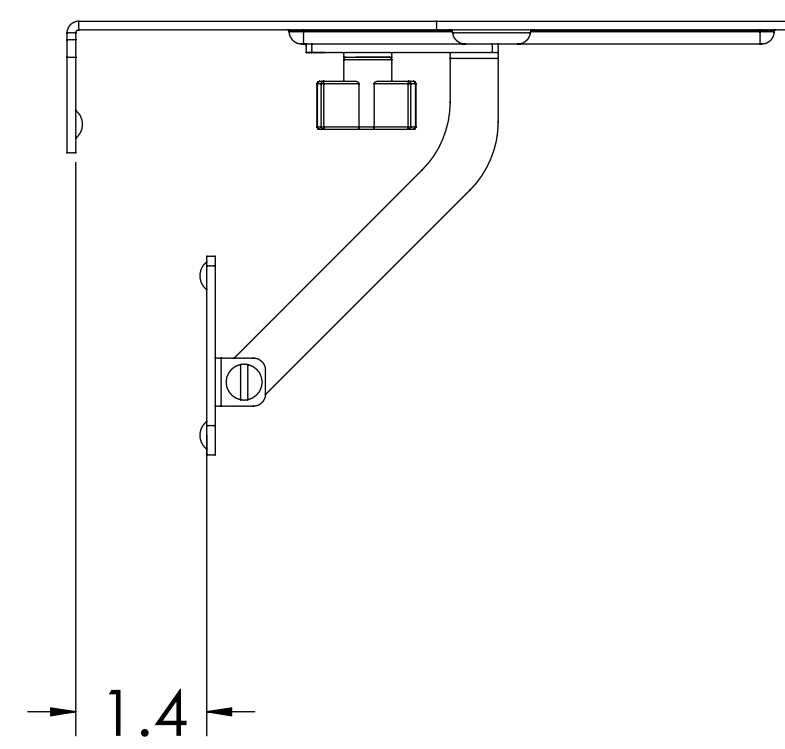
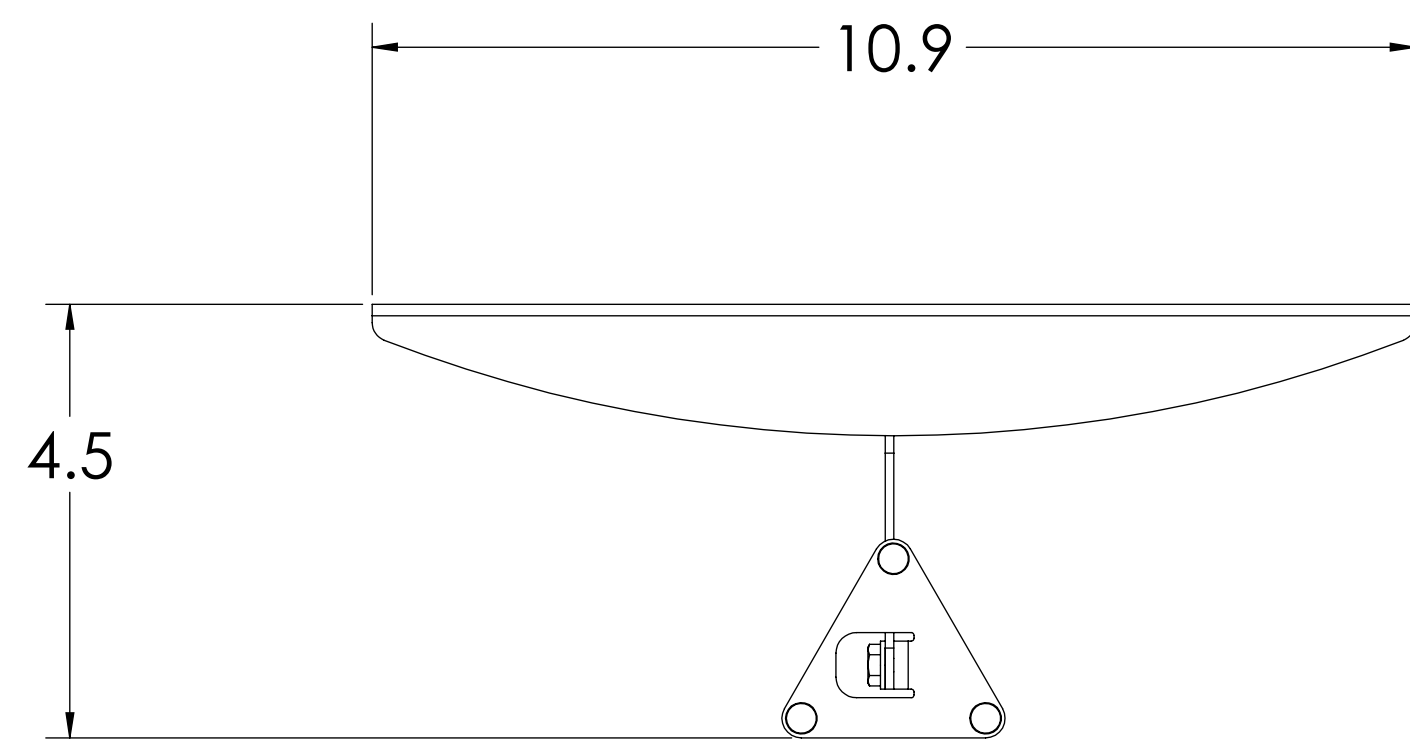
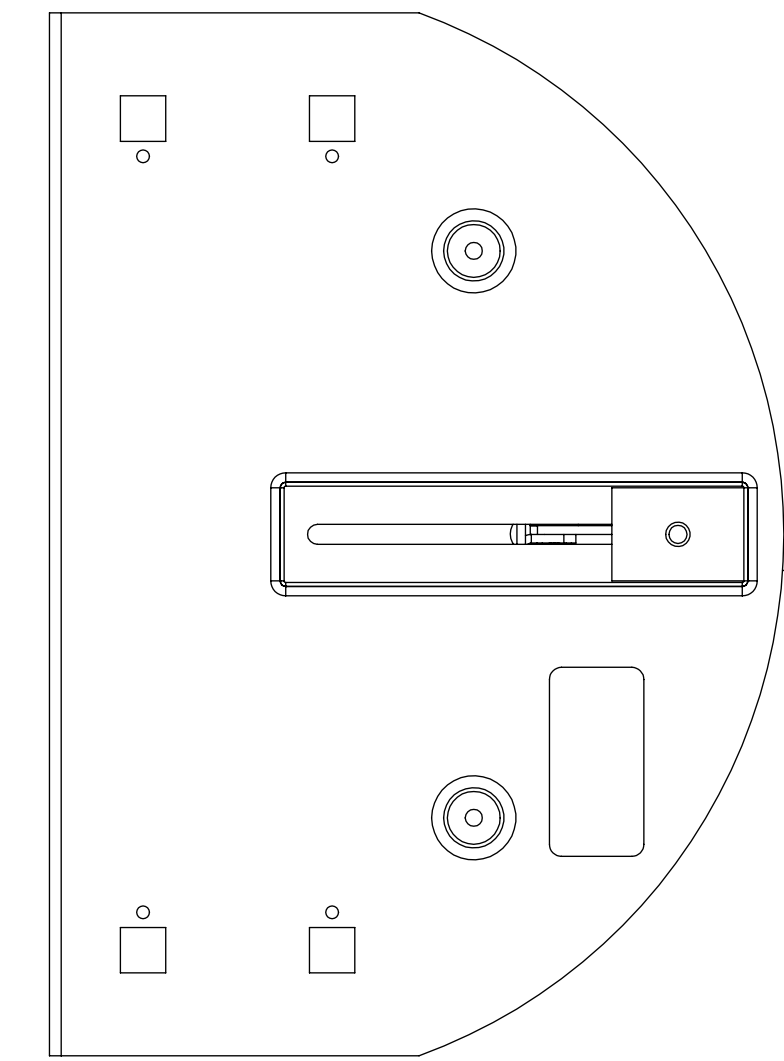
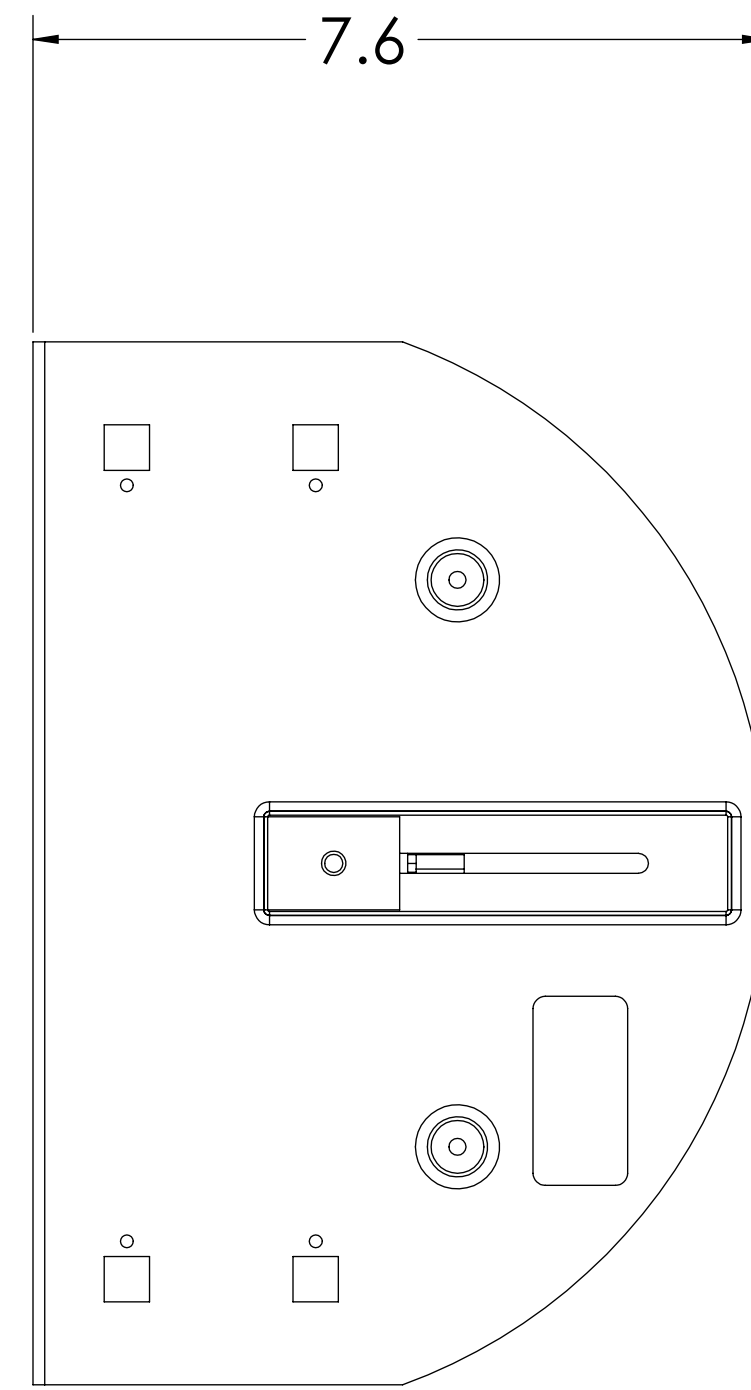

MINIMUM DISTANCE

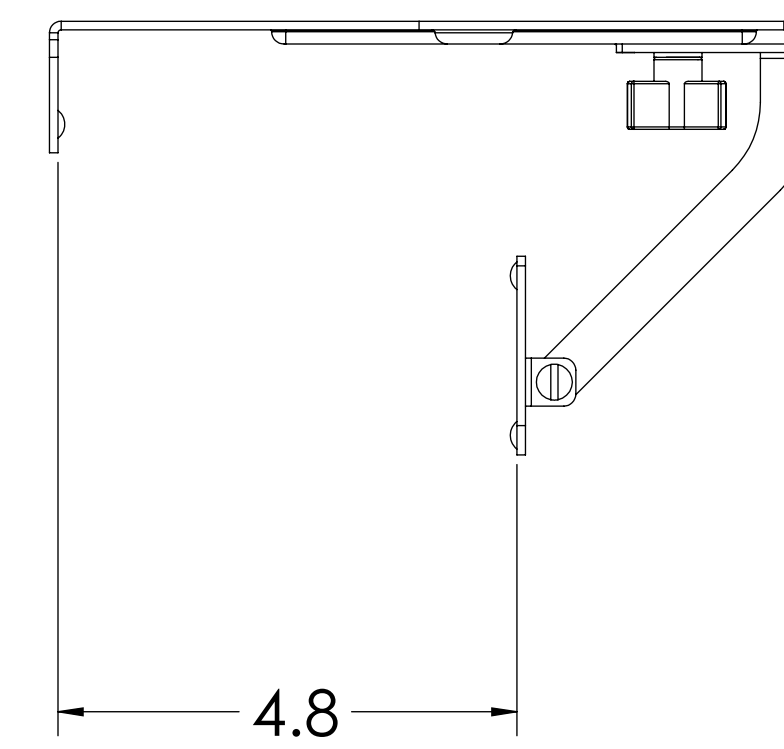

MAXIMUM DISTANCE



# WALL MOUNT

NOTES:  
1.) DIMENSIONS ARE INCHES

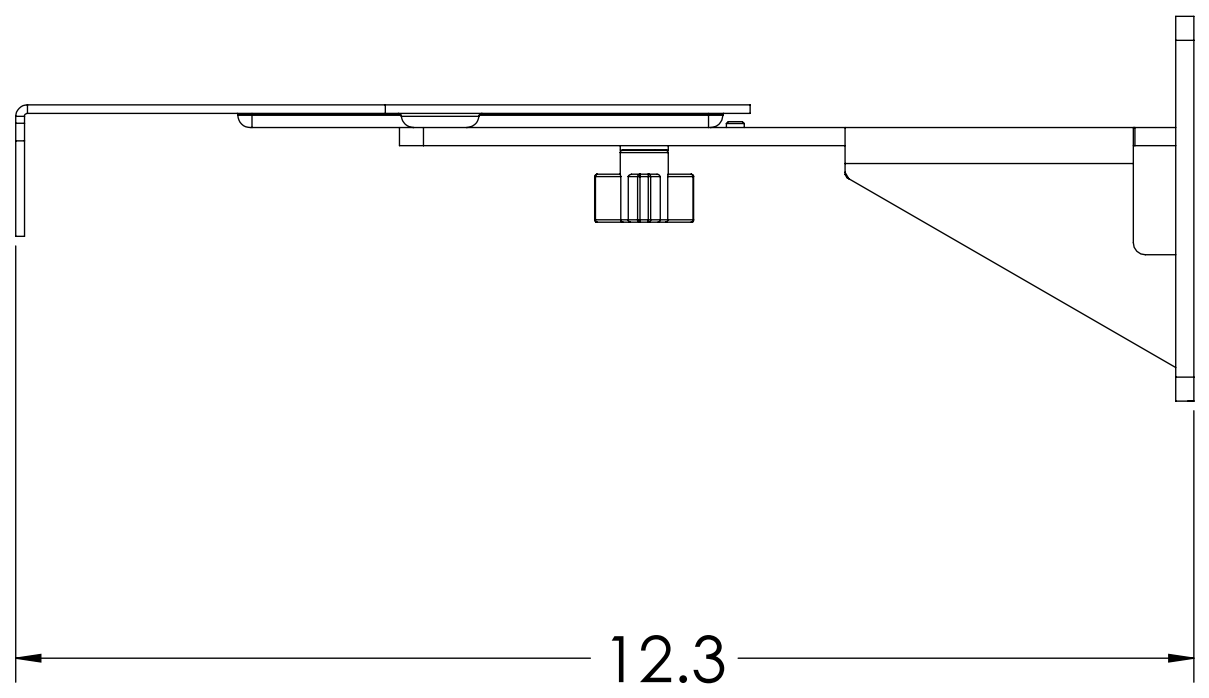
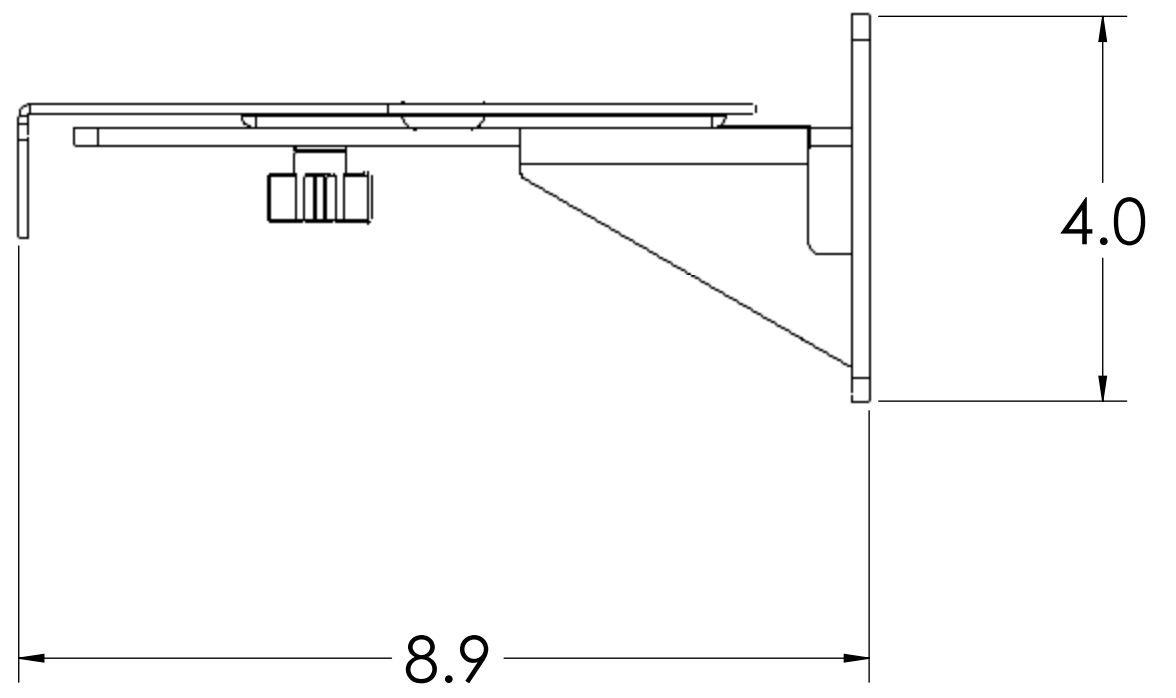
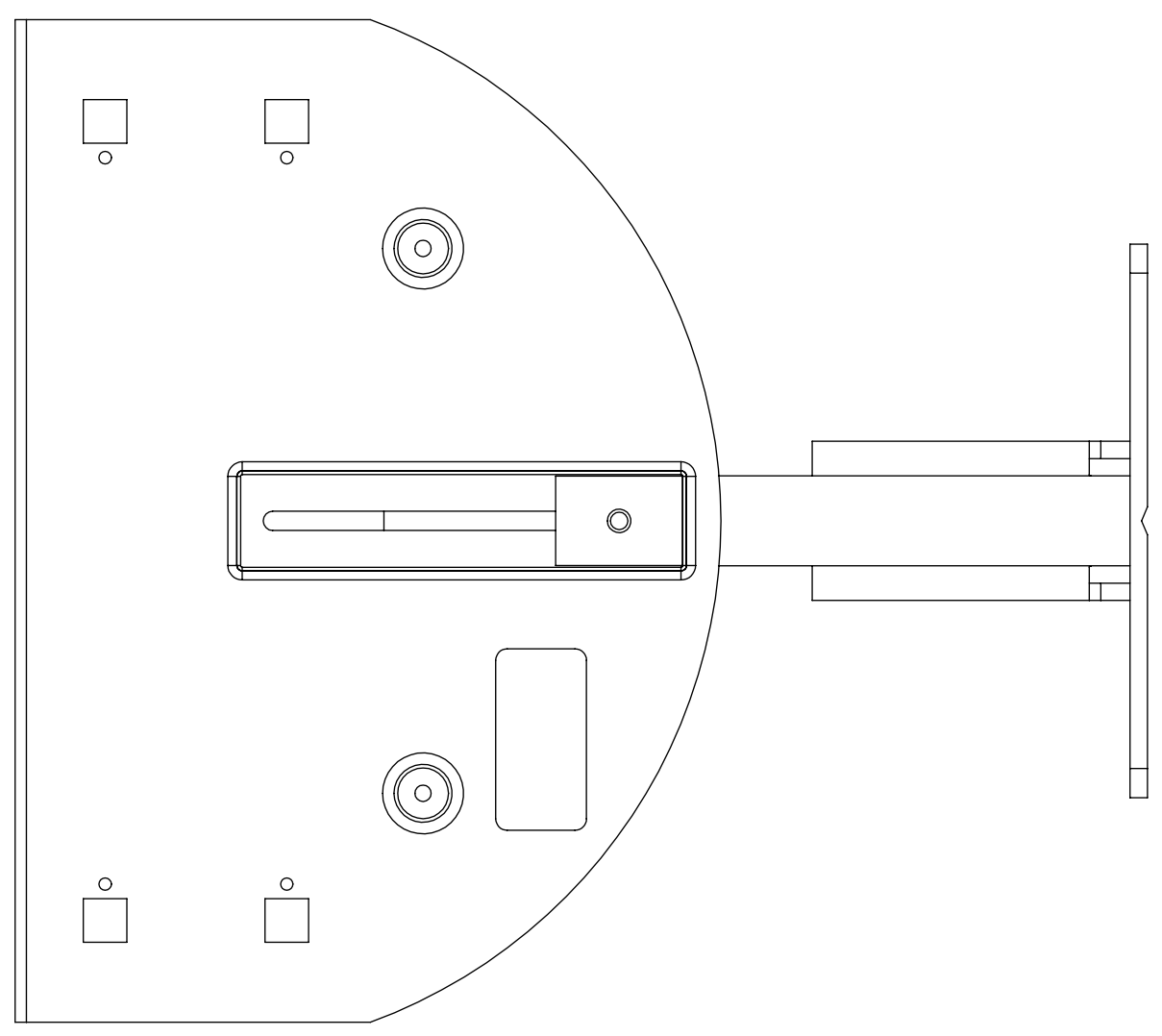
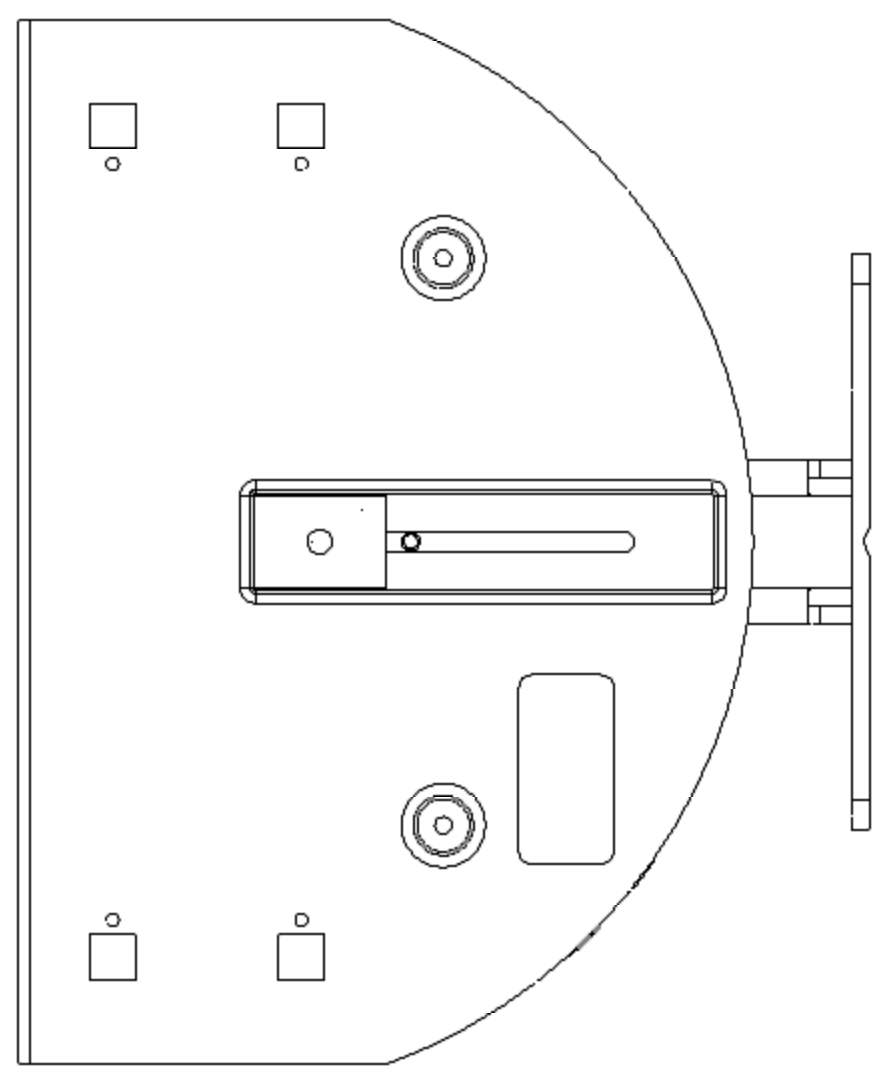
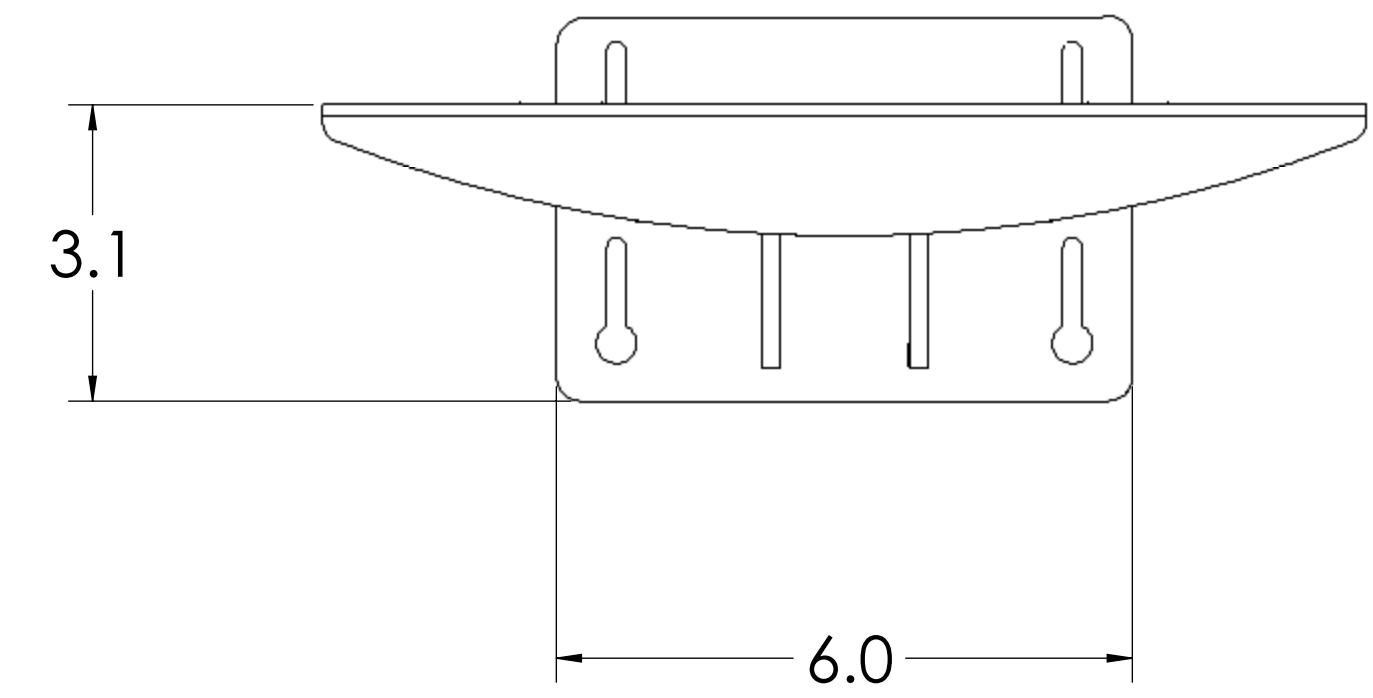

MINIMUM DISTANCE

MAXIMUM DISTANCE